



Standard Test Method for Drop Impact Resistance of Blow-Molded Thermoplastic Containers¹

This standard is issued under the fixed designation D2463; the number immediately following the designation indicates the year of original adoption or, in the case of revision, the year of last revision. A number in parentheses indicates the year of last reapproval. A superscript epsilon (ϵ) indicates an editorial change since the last revision or reapproval.

1. Scope*

1.1 This test method provides a means to assess the drop impact resistance of water-filled, blow-molded thermoplastic containers, which is a summation of the effects of material, manufacturing conditions, container design, and perhaps other factors.

1.2 Two procedures are provided as follows:

1.2.1 *Procedure A, Static Drop Height Method*—This procedure is particularly useful for quality control since it is quick.

1.2.2 *Procedure B, Bruceton Staircase Method*—This procedure is used to determine the mean failure height and the standard deviation of the distribution.

1.3 The values stated in SI units are to be regarded as standard. The inch-pound units given in parentheses are for information only.

NOTE 1—There is no known ISO equivalent to this standard.

1.4 *This standard does not purport to address all of the safety concerns, if any, associated with its use. It is the responsibility of the user of this standard to establish appropriate safety and health practices and determine the applicability of regulatory limitations prior to use.*

2. Referenced Documents

2.1 *ASTM Standards:*²

[B177 Guide for Engineering Chromium Electroplating](#)

[D883 Terminology Relating to Plastics](#)

[E691 Practice for Conducting an Interlaboratory Study to Determine the Precision of a Test Method](#)

¹ This test method is under the jurisdiction of ASTM Committee D20 on Plastics and is the direct responsibility of Subcommittee D20.19 on Film, Sheeting, and Molded Products.

Current edition approved April 1, 2015. Published April 2015. Originally approved in 1965. Last previous edition approved in 2010 as D2463 - 10b. DOI: 10.1520/D2463-15.

² For referenced ASTM standards, visit the ASTM website, www.astm.org, or contact ASTM Customer Service at service@astm.org. For *Annual Book of ASTM Standards* volume information, refer to the standard's Document Summary page on the ASTM website.

2.2 *Society of Plastics Industry Standard:*

[PBI-4 Test for Drop Impact Resistance of Plastic Bottles](#)³

3. Terminology

3.1 *Definitions:*

3.1.1 For definitions of terms found in this test method refer to Terminology [D883](#).

3.2 *Definitions of Terms Specific to This Standard:*

3.2.1 *failure, n*—any rupture visible to an observer with the unaided eye and normal eyesight is considered a failure; this includes also any evidence of contained liquid on the outside of the container through any aperture other than the molded opening.

4. Summary of Test Method

4.1 The drop impact resistance is determined by dropping conditioned blow-molded containers filled with water from a platform onto a prescribed surface. Data developed with a water-filled container are not always representative of what might be expected with a carbonated liquid, an aerosol pack, a product of high specific gravity, or a powder of low bulk density.

4.1.1 *Procedure A* consists of dropping at least 20 containers from a fixed height and reporting the percent failures.

4.1.2 *Procedure B* consists of dropping at least 20 test containers from varying heights above and below the mean failure height of the set. A mean failure height and standard deviation are then calculated from the data.

5. Significance and Use

5.1 These procedures provide a means to assess the drop impact resistance of the group or lot of blown containers from which the test specimens were selected.

5.2 It is acceptable to use these procedures for routine inspection purposes.

5.3 These procedures will evaluate the combined effect of construction, materials, and processing conditions on the impact resistance of the blown containers.

³ Available from the Society of the Plastics Industry, Inc., 1295 K Street, N.W., Washington, DC 20005.

*A Summary of Changes section appears at the end of this standard



FIG. 1 Apparatus for Dropping Containers

5.4 Before proceeding with this test method, reference the specification of the material being tested. Any test specimen preparation, conditioning, dimensions, or testing parameters, or combination thereof, covered in the materials specification shall take precedence over those mentioned in this test method. If there are no material specifications, then the default conditions apply.

6. Apparatus

6.1 *Drop Testing Machine* (see Fig. 1), having the following features:

6.1.1 A platform (see Fig. 2) upon which to set the test specimens, which can be raised or lowered either manually or by means of an electric motor.

6.1.2 The platform shall be adjustable to make it suitable for being leveled but shall also be stable so that it will not tilt under the weight of the test specimen.

6.1.3 The platform shall be spring-loaded so that upon release it will move rapidly out of the path of the test specimen and will not interfere with its fall.

6.1.4 A manually or electrically operated platform release mechanism that will hold the platform securely when being loaded but will release the platform instantaneously and will not interfere with its path of travel.

6.2 A surface on which the containers are dropped consisting of a flat hot-rolled steel plate, or equivalent, with minimum dimensions of 1000 mm by 1000 mm by 13 mm (36 in. by 36 in. by ½ in.) having an unpolished chrome-plated surface, plated in accordance with Practice B177, and securely attached to an industrial concrete surface or floor, so that the line of drop of the containers is perpendicular to the chrome-plated surface.

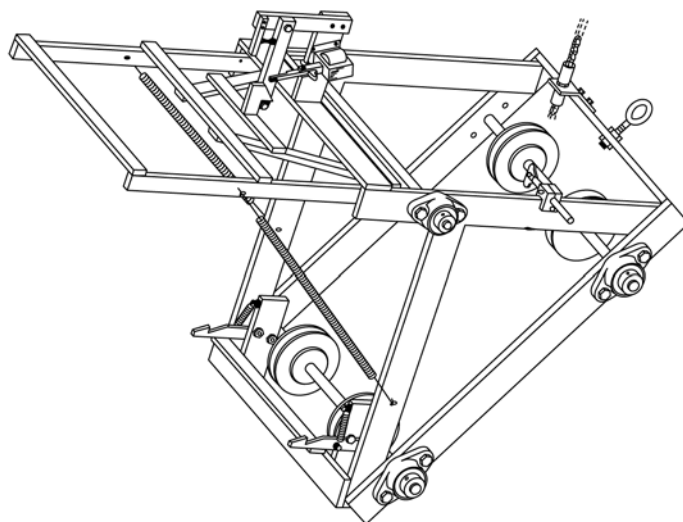

FIG. 2 Platform Assembly

6.3 A means of measuring the height of the platform above the impact surface.

6.3.1 If a more stringent impact test is desired, securely fasten a positioning jig capable of holding a test container at the proper angle for a 45° angle impact to the platform. When such a jig is used, the drop height must be measured from the lowest part of the container. Precision data are not available for testing under these conditions.

7. Test Specimens

7.1 A minimum of 20 containers shall be selected so they are representative of the lot being tested for any one of the test procedures. These shall be fitted with suitable closures.

8. Preparation of Apparatus

8.1 Periodically, or before each test series, check the platform of the drop impact machine, and adjust it if necessary, to ensure that the specimen will strike the impact area squarely on the desired surface. If this is necessary, use the following procedure:

8.1.1 Move the platform to the approximate mean failure height of the containers to be tested with a specimen on the platform in the desired position.

8.1.2 Release the platform allowing the specimen to fall onto the impact surface.

8.1.3 Take a snapshot picture of the container just before it strikes the impact surface. Two photographs shall be taken at right angles to each other to ascertain that the container impacts as desired—front to back and side to side. The position of the container relative to the impact surface as it appears in the photographs will indicate whether or not adjustments in the platform are necessary.

8.1.3.1 When photographs are taken, set up the camera approximately 300 mm (12 in.) above and 1800 mm (72 in.) from the impact area.

8.1.4 Inspect the photographs and make adjustments in the platform and repeat the procedure as specified in 8.1.1 as necessary.

9. Conditioning

9.1 Fill containers with tap water to their nominal fill capacity and condition them uncapped for 24 h at $23 \pm 2^\circ\text{C}$ ($73 \pm 3.6^\circ\text{F}$).

9.2 If the test is intended for immediate quality control, fill the containers with room temperature water and test at that temperature. A correlation shall have been previously developed by the testing laboratory between this type of test and that requiring 24-h conditioning.

9.2.1 It is acceptable to use conditioning temperatures other than $23 \pm 2^\circ\text{C}$ if desired, provided such conditioning is reported and adequate precautions are taken to ensure the containers are at that temperature during testing.

10. Procedure

10.1 Procedure A:

10.1.1 Set the platform at the test height of interest.

10.1.2 Drop at least 20 containers individually recording failures and non-failures.

10.2 Procedure B:

10.2.1 This procedure, used to determine the mean failure height of the test specimens, is called the “Up and Down” or Bruceton Staircase Method. It consists of dropping a set of test specimens from various heights, the drop height being raised or lowered depending on the result obtained on the specimen most recently tested; that is, if the previous specimen failed, the drop height is lowered; if the previous specimen did not fail, the drop height is raised.

10.2.2 Drop the first test container from 300 mm (12 in.) below the expected mean failure height. If the mean failure height is unknown several trial samples shall be tested by way of the staircase procedure to obtain at least two failures and two non-failures to establish the starting height.

10.2.3 Visually inspect and squeeze the container gently after impact to determine any pinhole type failures.

10.2.3.1 *Failure*—The container has failed a test if any one of the following occurs (see 3.2.1): (a) any rupture is visible with the unaided eye by an observer who has normal eyesight, or (b) any evidence is found of contained liquid on the outside of the container through any aperture other than the molded opening.

10.2.4 If the first test container dropped did not fail, drop the second container from a height of 300 mm (12 in.) higher. If the first container failed, drop the second container from a height of 300 mm (12 in.) lower.

10.2.5 Continue the testing until a minimum of 20 test containers have been dropped, raising or lowering the platform one interval (300 mm (12 in.)) depending on the results obtained on the most recently tested container.

10.2.6 Record the drop height and the results (failed or did not fail) on each container tested.

10.3 If a cap pops off during impact, consider that sample as a NO TEST and replace the sample with another container.

11. Calculations

11.1 Procedure A:

11.1.1 The percentage failures is calculated as follows:

$$\text{Failure, \%} = (X/N) \times 100$$

where:

X = number of failures, and

N = number of containers tested.

11.2 *Procedure B* (see X1.1 and Table X1.2 for clarification):

11.2.1 *Mean Failure Height*—Calculate the mean failure height from the test data obtained from Procedure B as follows:

$$h = h_o + d[(A/N) \pm \frac{1}{2}]$$

where:

h = mean failure height,

d = increment in height of drop,

N = number of failures or non-failures whichever is lesser,

h_o = lowest height at which any one of N occurs, and

$A = \sum_{i=0}^{i=k} in_i$ where $h_o, h_1, h_2, h_3,$ etc., are the heights in progressive order of magnitude in the range of heights where N occurs, i is the subscript of h , and n is the number of failures or non-failures, whichever is pertinent at the level of i . The negative sign is used in the parentheses to calculate h when N refers to failures and the positive sign when N is the number of non-failures.

11.2.2 *Cumulative Mean Failure Height (Graphical Method)*—See Table X1.2 for clarification.

11.2.3 *Standard Deviation*—Calculate the estimated deviation of the individual measurements from:

$$s = 1.620d \frac{NB - A^2}{N^2} + 0.029$$

where:

$d, N,$ and A are as in 11.2.1 and

$$B = \sum_{i=0}^{i=k} i^2 n_i$$

12. Report

12.1 Report the following information:

12.1.1 A complete description of the containers tested including size, style, material, method of processing, weight, date of manufacture, lot number, and any other information that would be important.

12.1.2 Description of contents if other than water, conditioning period, and temperature if other than $23 \pm 2^\circ\text{C}$ ($73 \pm 3.6^\circ\text{F}$).

12.1.3 The number of containers tested.

12.1.4 The test procedure used and the following:

12.1.4.1 *For Procedure A:* (1) Percentage of failures and the drop height.

12.1.4.2 *For Procedure B:* (1) Calculated mean failure height,

(2) Estimated standard deviation,

(3) Increment in height of drop,

(4) Lowest drop height at which a container failed, and

(5) Highest drop height at which a container did not fail.

NOTE 2—(4) and (5) of 12.1.4.2 indicate the range over which the containers were tested.

13. Precision and Bias⁴

13.1 An interlaboratory study was conducted using PVC bottles from one manufacturer. The average between-laboratory coefficients of variation were as follows:

- Procedure A 46%
- Procedure B 38%
- Procedure C 20%

13.2 An interlaboratory study was conducted using PE bottles from one manufacturer. The average between-laboratory coefficient of variation using Procedure B was 16 %.

13.3 An interlaboratory study (seven laboratories) was conducted by the Test Methods Subcommittee of the Plastics Bottle Institute of the Society of the Plastics Industry using one size of PVC bottles and two sizes of PE bottles. The testing was conducted as described in Technical Bulletin PBI-4. The

⁴ The round-robin data may be obtained from ASTM Headquarters. Request RR:D20-1045.

procedure in PBI-4 is equivalent to Procedure A of this test method. The results are as follows:

Bottle, oz	Material	Drop Height, ft	Values expressed as % Failed Based on 20 Bottles				
			Average	<i>S</i> (<i>r</i>)	<i>S</i> (<i>R</i>)	<i>l</i> (<i>r</i>)	<i>l</i> (<i>R</i>)
7.5	PVC	4	41.1	13.6	15.2	38.6	43.0
64	HDPE	5	65.5	11.3	22.1	31.9	62.5
128	HDPE	6	33.8	7.7	12.8	21.8	36.2

S(*r*) is the pooled within laboratory standard deviation of the average of 20 determinations. *S*(*R*) is the total among laboratory standard deviation of the average of 20 determinations. *l*(*r*) = 2.83 *S*(*r*), and *l*(*R*) = 2.83 *S*(*R*). The data was analyzed using Practice E691. It is possible that other materials or bottles, or both, will give somewhat different results.

NOTE 3—The above values are greatly influenced by testing bottles made in several cavities as if they came from a singles population that has been found, in many cases, not to be true. Therefore, if bottles from only one cavity are tested, the repeatability is expected to be considerably lower than the above values.

14. Keywords

14.1 blow-molded containers; drop impact; plastic containers

APPENDIX

(Nonmandatory Information)

X1. SAMPLE CALCULATIONS

X1.1 Procedure B

X1.1.1 Test results and calculations can be done as in Table X1.1.

TABLE X1.1 Procedure B

Drop Height, ft	Outcome of Test (X = failure; 0 = non-failure)																				<i>n_x</i>	<i>n_o</i>	<i>i</i>	<i>n_i</i>	<i>in_i</i>	<i>i² n_i</i>
	1	2	3	4	5	6	7	8	9	10	11	12	13	14	15	16	17	18	19	20						
5	0				0		0												0		0	4
6		0		X		X		0		0			0					X		X	4	4	0	4	0	0
7			X						X		0		X		0		X				4	2	1	4	4	4
8											X					X					2	0	2	2	4	8
Totals																				10 (<i>N_x</i>)	10 (<i>N_o</i>)	...	10 (<i>N</i>)	8 (<i>A</i>)	12 (<i>B</i>)	

Ten failed and ten did not fail so either failures or non-failures may be used in the calculation. This illustration has been based on failures (negative sign used).

$$h_o = 6, N = N_x = 10, d = 1$$

$$h = h_o + d(A/N - 1/2)$$

$$h = 6 + 1(8/10 - 1/2) = 6.3 \text{ ft}$$

$$s = 1.62d((NB - A^2/N^2) + 0.029)$$

$$s = (1.62)(1) ((10)(12) - (8)(8)/(10)) (10) + 0.029 = 0.95 \text{ ft}$$

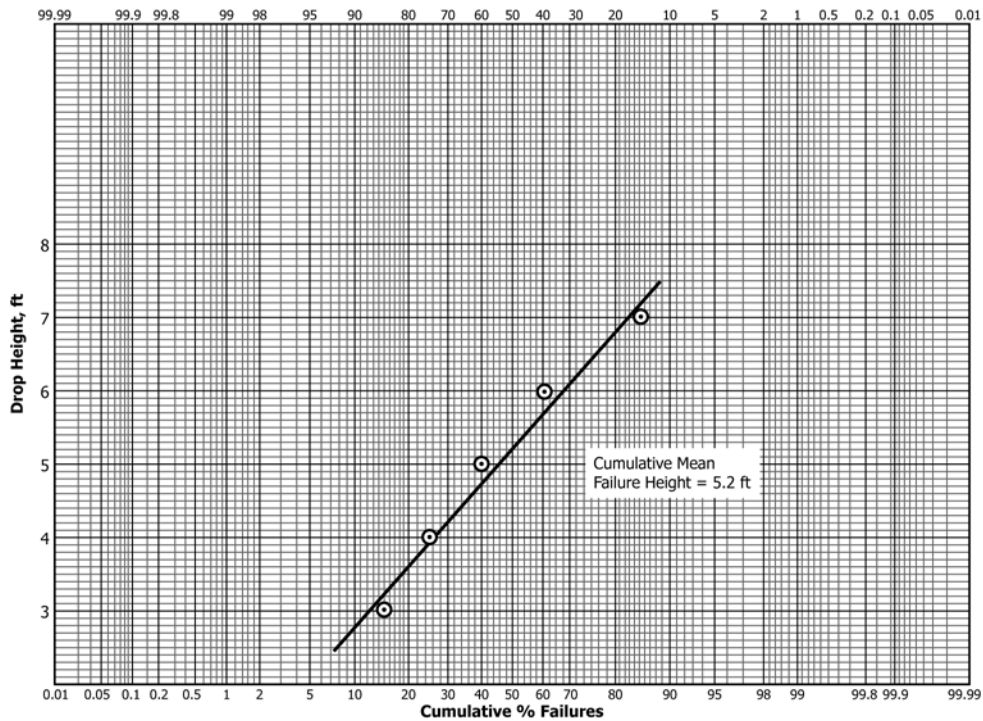

FIG. X1.1 Cumulative Mean Failure Height by the Graphic Method

TABLE X1.2

Height of Drop, ft	Number Failing	Percent Failing	Cumulative % Failing
3	3	15	15
4	2	10	25
5	3	15	40
6	4	20	60
7	5	25	85
8	3	15	100
Sum = 20			

SUMMARY OF CHANGES

Committee D20 has identified the location of selected changes to this standard since the last issue (D2463 – 10b) that may impact the use of this standard. (April 1, 2015)

- (1) Eliminated reference to three procedures in the standard.
- (2) Re-ordered parts of Section 10, Procedure.
- (3) Corrected grammatical errors throughout.

ASTM International takes no position respecting the validity of any patent rights asserted in connection with any item mentioned in this standard. Users of this standard are expressly advised that determination of the validity of any such patent rights, and the risk of infringement of such rights, are entirely their own responsibility.

This standard is subject to revision at any time by the responsible technical committee and must be reviewed every five years and if not revised, either reapproved or withdrawn. Your comments are invited either for revision of this standard or for additional standards and should be addressed to ASTM International Headquarters. Your comments will receive careful consideration at a meeting of the responsible technical committee, which you may attend. If you feel that your comments have not received a fair hearing you should make your views known to the ASTM Committee on Standards, at the address shown below.

This standard is copyrighted by ASTM International, 100 Barr Harbor Drive, PO Box C700, West Conshohocken, PA 19428-2959, United States. Individual reprints (single or multiple copies) of this standard may be obtained by contacting ASTM at the above address or at 610-832-9585 (phone), 610-832-9555 (fax), or service@astm.org (e-mail); or through the ASTM website (www.astm.org). Permission rights to photocopy the standard may also be secured from the Copyright Clearance Center, 222 Rosewood Drive, Danvers, MA 01923, Tel: (978) 646-2600; http://www.copyright.com/