



Standard Test Method for Water Retention of Textile Fibers (Centrifuge Procedure)¹

This standard is issued under the fixed designation D2402; the number immediately following the designation indicates the year of original adoption or, in the case of revision, the year of last revision. A number in parentheses indicates the year of last reapproval. A superscript epsilon (ϵ) indicates an editorial change since the last revision or reapproval.

1. Scope

1.1 This test method covers the measurement of water retention of man-made and natural fibers as staple, tow, or filament and spun yarns. It is intended to give a measure of the amount of water which cannot be removed from thoroughly wetted fiber solely by mechanical means as applied by centrifugal force (see 3.2).

1.2 *This standard does not purport to address all of the safety concerns, if any, associated with its use. It is the responsibility of the user of this standard to establish appropriate safety and health practices and determine the applicability of regulatory limitations prior to use.* For specific precautionary statements, see Section 9.

2. Referenced Documents

2.1 *ASTM Standards:*²

D123 Terminology Relating to Textiles

D629 Test Methods for Quantitative Analysis of Textiles

D2258 Practice for Sampling Yarn for Testing

D3333 Practice for Sampling Manufactured Staple Fibers, Sliver, or Tow for Testing

D4849 Terminology Related to Yarns and Fibers

3. Terminology

3.1 For all terminology relating to D13.58, Yarns and Fibers, refer to Terminology D4849.

3.1.1 The following terms are relevant to this standard: moisture pick-up, water retention.

3.2 For all other terminology related to textiles, refer to Terminology D123.

4. Summary of Test Method

4.1 A specimen is thoroughly wetted-out by immersion, centrifuged for 5 min at an acceleration of 9800 m/s² and

weighed wet. Then, the wet specimen is dried and reweighed. Water retention is calculated and reported as a percentage of the dry mass.

5. Significance and Use

5.1 This test method for testing for water retention of fibers after centrifuging is not recommended for acceptance testing of commercial shipments because the test is more appropriate for development and research. However, if the test is to be used for acceptance testing, comparative tests as described in 5.1.1 are advised.

5.1.1 In the case of a dispute arising from differences in reported test results using Test Method D2402 for acceptance testing of commercial shipments, the purchaser and the supplier should conduct comparative tests to determine if statistical biases exist between their laboratories. As a minimum, the two parties should take a group of test specimens that are as homogeneous as possible and that are from a lot of material of the type in question. The test specimens should then be randomly assigned in equal numbers to each laboratory for testing. The average results from the two laboratories should be compared using the Student's *t*-test for unpaired data with an acceptable probability level chosen by the two parties while designing the test program. If the analysis shows a bias, its cause must be found and corrected, or the purchaser and supplier must agree to interpret future test data with consideration for the known bias.

5.2 The amount of water retained by a fiber mass increases with an increase in the hydrophilic tendency of the fiber. Thus the data obtained can be used to indicate the following:

5.2.1 Differences in water retention between the various man-made and natural fibers,

5.2.2 Degree of cross-linking in cellulosic fibers,

5.2.3 Damage incurred by wool and silk fibers due to alkaline processing, and

5.2.4 Persistence of water-repellent treatments.

6. Apparatus

6.1 *Stationary Coarse Comb*³, approximately 63 mm long and having needles approximately 12.5 mm long and spaced 19 needles to the 10 mm, or

³ Combs meeting these requirements may be obtained from Alfred Suter Co., Inc., Prel Plaza, Orangeburg, NY 10962.

¹ This test method is under the jurisdiction of ASTM Committee D13 on Textiles and is the direct responsibility of Subcommittee D13.58 on Yarns and Fibers.

Current edition approved July 1, 2012. Published August 2012. Originally approved in 1965T Last previous edition approved in 2007 as D2402 – 07. DOI: 10.1520/D2402-07R12.

² For referenced ASTM standards, visit the ASTM website, www.astm.org, or contact ASTM Customer Service at service@astm.org. For *Annual Book of ASTM Standards* volume information, refer to the standard's Document Summary page on the ASTM website.

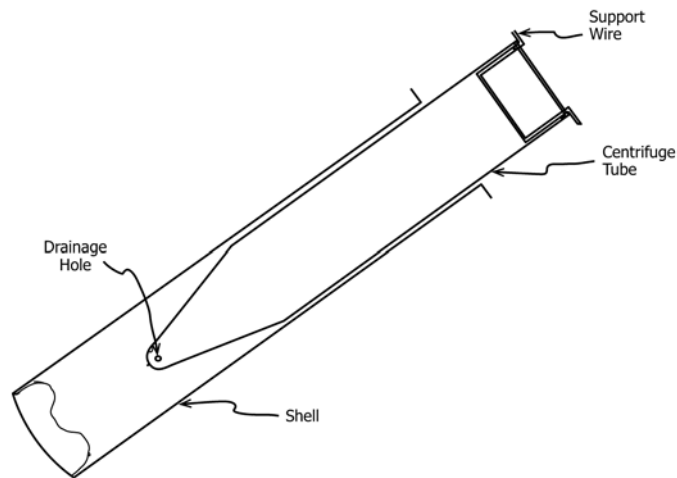

FIG. 1 Cross-section View of Centrifuge Tube Assembly

6.2 Hand Cards.

6.3 *Centrifuge*,⁴ with trunnions capable of holding at least 2 tube assemblies. The centrifuge must be capable of operating to develop an angular speed that will produce a radial acceleration of 9800 m/s² (1000 g) on the specimen within 5 min.

6.4 *Tube Assemblies*, each consisting of a 15-mL, polypropylene, centrifuge tube with draining holes, shell and support wire (see Fig. 1).

6.5 *Timer*, suitable for controlling immersion time and centrifuge time to ± 1 s.

6.6 *Balance*, with sensitivity of 0.5 mg and a capacity of 2000 g.

6.7 *Weighing Containers*, air-tight, large enough to hold a specimen basket.

6.8 *Oven*, convection type, maintained at 105 to 110°C.

6.9 *Desiccator*, with an efficient desiccant such as anhydrous silica gel, anhydrous calcium sulfate, or phosphorous pentoxide.

6.10 *Bell Jar*, optional, see 10.5.1.

7. Hazard

7.1 Sodium hydroxide (see Note 4) is a strong base and must be handled with appropriate safety precautions. Refer to the manufacturer's material safety data sheet information.

8. Sampling

8.1 *Lot Sample*—As a lot sample for acceptance testing, take at random the number of shipping containers directed in the applicable material specification or other agreement between the purchaser and supplier, such as an agreement to use Practice D3333 for staple fiber, sliver, top or tow, or to use Practice D2258 for yarn. Consider the shipping containers to be the primary sampling units.

NOTE 1—An adequate specification or other agreement between the purchaser and supplier requires taking into account the variability between

shipping containers, between laboratory samples within the shipping container, and between test specimens within a laboratory sample, to provide a sampling plan with a meaningful producer's risk, consumer's risk, acceptable quality level, and limiting quality level.

8.2 *Laboratory Sample*—As a laboratory sample for acceptance testing, proceed as follows:

8.2.1 *For Staple Fiber*—Systematically take five laboratory sample subunits from each bale in the lot sample as directed in Practice D3333.

8.2.2 *For Tow and Sliver (or Top)*—From each shipping container in the lot sample, take at least a metre, or yard, of material from the leading end of the textile strand that has a clean uniform appearance. If the shipping container has multiple packages, take one package drawn at random from the container for that laboratory sample.

8.2.3 *For Yarn in Cases*—Take ten yarn packages as directed in Practice D2258. Remove enough traverses of yarn to obtain a surface free of visible damage or soil, and then remove at least a gram of yarn for the laboratory sample from each laboratory sampling unit.

8.2.4 *For Yarn on Beams*—Sample as agreed upon between the purchaser and supplier.

8.3 *Test Specimens*—Test two 0.5 g specimens from each laboratory sampling unit, preferably from different sections of the laboratory sample units.

9. Conditioning

9.1 Specimens may be tested without any conditioning.

10. Specimen Preparation

10.1 *Foreign Matter and Extractable Matter*—If the laboratory sample units contain foreign matter, remove the latter by mechanical means (such as hand carding). For samples containing nonfibrous natural constituents of the fiber (such as oils and waxes) or substances added by the manufacturer (such as finish, starch, soaps, waxes, etc.), extract portions by one or more of the treatments prescribed in Section 8 on Nonfibrous Materials of Test Methods D629. Use air-drying instead of oven-drying.

NOTE 2—In general, avoid use of temperatures above 50°C since such

⁴ A clinical safety-head centrifuge is satisfactory for this procedure.

temperatures often affect fiber structure and, thus, water retention.

10.2 Staple:

10.2.1 Prepare composites of each the laboratory sample units by taking about 0.1 g portions from different areas of each of the five laboratory subunits for 0.5 g specimens.

10.2.2 Using a stationary comb or hand cards, carefully parallelize the fibers.

10.2.3 Prepare 0.5 ± 0.05 g specimens of the carded fiber and tie the bundles in their midsections, using some of the same fiber or a small wire (for example 30-gage Nichrome). (See 11.3.) Form a loop with the tying fibers, or hook or loop with the wire, for suspending the bundle from the support wire of the centrifuge tube. Remove any loose fibers from the bundle before weighing.

NOTE 3—If wire is used, it must be weighed as part of the weighing container tare mass (11.3) before use in fastening the specimen bundle.

10.3 Tow or Sliver (Top):

10.3.1 For tow, cut sections, 500 to 1000 mm in length, from different areas of a laboratory tow sample and split off 0.5 ± 0.05 g specimens from the side. Fasten the specimen as directed in 10.2.3.

10.3.2 For sliver (top), draft short segments from different sections of a laboratory sample and split off 0.5 ± 0.05 g specimens from the side. Fasten the specimen as directed in 10.2.3.

10.4 Yarn:

10.4.1 Prepare two 0.5 g skeins by winding an appropriate number of turns on a tapered mandrel (Note 4) from different sections of each of the laboratory sample units.

NOTE 4—A No. 4 rubber stopper, which has been boiled in sodium hydroxide solution to remove sulfur, has been found to be a convenient size (see 7.1).

10.4.2 Tie each of the skeins in two places about half the circumference apart using yarn of the same supply.

11. Procedure

11.1 Make all weighings in the standard atmosphere for testing textiles, which is $21 \pm 1^\circ\text{C}$ ($70 \pm 2^\circ\text{F}$) and $65 \pm 2\%$ relative humidity.

11.2 Calculate the angular speed required to produce a radial acceleration of 9800 m/s^2 (1000 g), using Eq 1:

$$n = (8.943 \times 10^6 \times 1/r)^{1/2} \quad (1)$$

where:

n = revolutions per minute, and
 r = radial distance of the fiber mass from the center of rotation, mm.

11.3 Weigh dry, identified weighing containers and covers to the nearest 0.001 g. If wire is needed to tie specimen bundles (10.2.3), include the wire in the individual container tare masses. Record each tare mass, T.

11.4 Immerse each prepared specimen in an identified beaker of distilled water at room temperature for 5 min, or longer if needed to completely wet out the specimen. Record the immersion time.

11.4.1 If air is entrapped in the specimen, remove the air bubbles either by (1) mechanical agitation, or (2) covering the beaker and specimen with a bell jar and lowering the air pressure until the water boils.

11.5 At the end of the immersion period, remove the specimen from the distilled water. Attach the specimen to the tube assembly support wire through the yarn skein, or fiber or wire loop or wire hook of the fiber bundle.

11.6 Suspend the specimen in an identified centrifuge tube by the support wire.

NOTE 5—Dissection needles may be useful in inserting the specimen in the tube.

11.7 Transfer the tubes to the centrifuge. Distribute the tubes evenly spaced about the centrifuge, filling in with empty tubes as needed to balance the load.

11.8 Start the centrifuge and spin for $5 \text{ min} \pm 5 \text{ s}$, including acceleration time.

11.9 At the end of the spin, stop the centrifuge quickly and immediately transfer the specimens back to their individual weighing containers and put the covers on.

11.10 Weigh the containers with the specimens, and wires if used, to the nearest 0.001 g. Record each wet mass, M.

11.11 Place the wet specimens, weighing containers, covers, and wires, if any, in the oven and dry them at 105 to 110°C for about 1.5 h.

11.12 Transfer the dry specimens with their weighing containers, covers, and wires, if any, to the desiccator and cool.

11.13 Weigh the dried specimens with their weighing containers, covers, and wires, if any, to the nearest 0.001 g. Record these masses as dry mass, D.

12. Calculation

12.1 Calculate the water retention, to the nearest 0.1 %, using Eq 2:

$$R = 100(M - D)/(D - T) \quad (2)$$

where:

R = water retention, %,
 M = mass of moist specimen with its tare mass (11.10), g,
 D = mass of dried specimen with its tare mass (11.13), g,
 and
 T = mass of the tare (see 11.3).

12.2 Calculate the average percent water retention for the two specimens for each laboratory sampling unit, and the average for the lot.

12.3 If requested, calculate the standard deviation, or coefficient of variation, or both, for each laboratory sampling unit and for the lot.

13. Report

13.1 State that the samples were tested as described in Test Method D2402. Describe the material(s) and product(s) sampled, and the method of sampling used.

13.2 Report the following information:

TABLE 1 Analysis of Data

	Cotton			Polyester		
	Oper 1	Oper 2	Combined	Oper 1	Oper 2	Combined
Number	12	12	24	12	12	24
Average in %	30.20	32.80	31.46	4.821	4.077	4.453
Standard deviation	0.860	0.859	1.566	0.257	0.426	0.525
% CV			4.98			11.79

13.2.1 The individual and average percent water retention for each laboratory sampling unit,

13.2.2 The average percent water retention for the lot,

13.2.3 The standard deviation, or the coefficient of variation, or both, if calculated, and

13.2.4 The range for the immersion times for the specimens.

ASTM International takes no position respecting the validity of any patent rights asserted in connection with any item mentioned in this standard. Users of this standard are expressly advised that determination of the validity of any such patent rights, and the risk of infringement of such rights, are entirely their own responsibility.

This standard is subject to revision at any time by the responsible technical committee and must be reviewed every five years and if not revised, either reapproved or withdrawn. Your comments are invited either for revision of this standard or for additional standards and should be addressed to ASTM International Headquarters. Your comments will receive careful consideration at a meeting of the responsible technical committee, which you may attend. If you feel that your comments have not received a fair hearing you should make your views known to the ASTM Committee on Standards, at the address shown below.

This standard is copyrighted by ASTM International, 100 Barr Harbor Drive, PO Box C700, West Conshohocken, PA 19428-2959, United States. Individual reprints (single or multiple copies) of this standard may be obtained by contacting ASTM at the above address or at 610-832-9585 (phone), 610-832-9555 (fax), or service@astm.org (e-mail); or through the ASTM website (www.astm.org). Permission rights to photocopy the standard may also be secured from the Copyright Clearance Center, 222 Rosewood Drive, Danvers, MA 01923, Tel: (978) 646-2600; http://www.copyright.com/

14. Precision and Bias

14.1 *Precision*—Because of the limited use of Test Method D2402 for water retention of textile fibers, data has been obtained for a within laboratory comparison instead of the usual interlaboratory comparison test. Two operators in one laboratory tested twelve specimens from each of two materials, cotton and polyester, representing two levels of water retention. Data, tabulated below shows more variance at the lower levels of water retention. See **Table 1**.

14.2 *Bias*—The procedure in Test Method D2402 for measuring the water retention of fibers has no bias because the value for this property can be measured only in terms of a test method.

15. Keywords

15.1 textile fibers; water retention