



Standard Test Method for Thermal Endurance of Rigid Electrical Insulating Materials¹

This standard is issued under the fixed designation D2304; the number immediately following the designation indicates the year of original adoption or, in the case of revision, the year of last revision. A number in parentheses indicates the year of last reappraisal. A superscript epsilon (ϵ) indicates an editorial change since the last revision or reappraisal.

1. Scope

1.1 This test method² provides procedures for evaluating the thermal endurance of rigid electrical insulating materials. Dielectric strength, flexural strength, or water absorption are determined at room temperature after aging for increasing periods of time in air at selected-elevated temperatures. A thermal-endurance graph is plotted using a selected end point at each aging temperature. A means is described for determining a temperature index by extrapolation of the thermal endurance graph to a selected time.

1.2 This test method is most applicable to rigid electrical insulation such as supports, spacers, voltage barriers, coil forms, terminal boards, circuit boards and enclosures for many types of application where retention of the selected property after heat aging is important.

1.3 When dielectric strength is used as the aging criterion, it is also acceptable to use this test method for some thin sheet (flexible) materials, which become rigid with thermal aging, but is not intended to replace Test Method D1830 for those materials which must retain a degree of flexibility in use.

1.4 This test method is not applicable to ceramics, glass, or similar inorganic materials.

1.5 The values stated in metric units are to be regarded as standard. Other units (in parentheses) are provided for information.

1.6 *This standard does not purport to address all of the safety concerns, if any, associated with its use. It is the responsibility of the user of this standard to establish appropriate safety and health practices and determine the applicability of regulatory limitations prior to use.* A specific warning statement is given in 10.3.4.

¹ This test method is under the jurisdiction of ASTM Committee D09 on Electrical and Electronic Insulating Materials and is the direct responsibility of Subcommittee D09.07 on Flexible and Rigid Insulating Materials.

Current edition approved Oct. 1, 2010. Published October 2010. Originally issued as D2304 – 64 T. Last previous edition approved in 2002 as D2304 – 97R02. DOI: 10.1520/D2304-10.

² This test method is a revision of a procedure written by the Working Group on Rigid Electrical Insulating Materials of the Subcommittee on Thermal Evaluation, IEEE Electrical Insulation Committee, which was presented as CP 59-113 at the IEEE Winter General Meeting Feb. 1–6, 1959. See references at end of this test method.

2. Referenced Documents

2.1 ASTM Standards:³

D149 Test Method for Dielectric Breakdown Voltage and Dielectric Strength of Solid Electrical Insulating Materials at Commercial Power Frequencies

D229 Test Methods for Rigid Sheet and Plate Materials Used for Electrical Insulation

D570 Test Method for Water Absorption of Plastics

D790 Test Methods for Flexural Properties of Unreinforced and Reinforced Plastics and Electrical Insulating Materials

D1830 Test Method for Thermal Endurance of Flexible Sheet Materials Used for Electrical Insulation by the Curved Electrode Method

D5423 Specification for Forced-Convection Laboratory Ovens for Evaluation of Electrical Insulation

2.2 IEEE:⁴

No. 1 General Principles Upon Which Temperature Limits Are Based in the Rating of Electric Equipment

No. 98 Guide for the Preparation of Test Procedures for the Thermal Evaluation of Electrical Insulating Materials

No. 101 Guide for the Statistical Analysis of Test Data

3. Terminology

3.1 Definitions:

3.1.1 *Arrhenius plot, n*—a graph of the logarithm of thermal life as a function of the reciprocal of absolute temperature.

3.1.1.1 *Discussion*—This is normally depicted as the best straight line fit, determined by least squares, of end points obtained at aging temperatures. It is important that the slope, which is the activation energy of the degradation reaction, be approximately constant within the selected temperature range to ensure a valid extrapolation.

3.1.2 *temperature index, n*—a number which permits comparison of the temperature/time characteristics of an electrical insulating material, or a simple combination of materials, based on the temperature in degrees Celsius which is obtained by

³ For referenced ASTM standards, visit the ASTM website, www.astm.org, or contact ASTM Customer Service at service@astm.org. For *Annual Book of ASTM Standards* volume information, refer to the standard's Document Summary page on the ASTM website.

⁴ Available from the Institute of Electrical and Electronics Engineers, 445 Hoes Ln., P.O. Box 1331, Piscataway, NJ 08854-1331.

extrapolating the Arrhenius plot of life versus temperature to a specified time, usually 20 000 h.

3.1.3 *thermal life, n*—the time necessary for a specific property of a material, or a simple combination of materials, to degrade to a defined end point when aged at a specified temperature.

3.1.4 *thermal life curve, n*—a graphical representation of thermal life at a specified aging temperature in which the value of a property of a material, or a simple combination of materials, is measured at room temperature and the values plotted as a function of time.

3.2 *Definitions of Terms Specific to This Standard:*

3.2.1 *rigid electrical insulating material, n*—an electrical insulating material having a minimum flexural modulus of 690 MPa and minimum use thickness of 0.5 mm (0.02 in.). It is generally used as terminal boards, spacers, coil forms, voltage barriers, and circuit boards.

4. Summary of Test Method

4.1 Test specimens are aged in air at three or preferably four temperatures above the expected use temperature. The aging temperatures are selected so that the thermal life is at least 100 h at the highest aging temperature and 5000 h at the lowest aging temperature. A thermal-life curve is plotted for each aging temperature. The values of thermal life determined from the thermal-life curve are used to plot the thermal-endurance graph. A temperature index is determined from the thermal-endurance graph for each aging criterion used. (It is possible to obtain different values for the thermal index of a material with different aging criteria.)

5. Significance and Use

5.1 Thermal degradation is often a major factor affecting the life of insulating materials and the equipment in which they are used. The temperature index provides a means for comparing the thermal capability of different materials in respect to the degradation of a selected property (the aging criterion). This property needs to directly or indirectly represent functional needs in application. For example, it is possible that a change in dielectric strength will be of direct, functional importance. However, more often it is possible that a decrease in dielectric strength will indirectly indicate the development of undesirable cracking (embrittlement). A decrease in flexural strength has the potential to be of direct importance in some applications, but also has the potential to indirectly indicate a susceptibility to failure in vibration. Often, it is necessary that two or more criteria of failure be used; for example, dielectric strength and flexural strength.

5.2 Other factors, such as vibration, moisture and contaminants, have the potential to cause failure after thermal degradation takes place. In this test method, water absorption provides one means to evaluate such considerations.

5.3 For some applications, the aging criteria in this test method will not be the most suitable. Other criteria, such as elongation at tensile or flexural failure, or resistivity after exposure to high humidity or weight loss, have the potential to serve better. The procedures in this test method have the

potential to be used with such aging criteria. It is important to consider both the nature of the material and its application. For example, it is possible that tensile strength will be a poor choice for glass-fiber reinforced laminates, because it is possible that the glass fiber will maintain the tensile strength even when the associated resin is badly deteriorated. In this case, flexural strength is a better criterion of thermal aging.

5.4 When dictated by the needs of the application, it is possible that an aging atmosphere other than air will be needed and used. For example, thermal aging can be conducted in an oxygen-free, nitrogen atmosphere.

6. End Point

6.1 An expression of the thermal life of a material, even for comparative purposes only, inevitably involves the choice of an end point. The end point could be a fixed magnitude of the property criterion, a percentage reduction from its initial magnitude, the minimum magnitude obtainable with time (that is, when change with time ceases), or a fixed degrading change rate (that is, a fixed value for the negative derivative of property with respect to time).

6.2 Experience has shown that the choice of an end point can affect the comparative thermal life. A choice of end points needs to, therefore, be guided by the limiting requirements imposed on the insulation by the manner and conditions of use in the complete system. End points are not specified in this test method. The first concern is to determine the values of the chosen properties as a function of time of thermal exposure at specified temperatures. The properties are determined at various intervals of time until a practical minimum or maximum magnitude, whichever is applicable, is reached. The data that result are thus universal, that is, usable for any subsequently chosen end point as determined by the specific application of the rigid electrical insulation.

6.3 The specification for each material needs to state the end point to be used.

7. Aging Ovens

7.1 The accuracy of the test results will depend on the accuracy with which the exposure temperature of the test specimens is known. Experience has shown, as indicated in [Table 1](#), that the thermal life is approximately halved for a 10°C increase in exposure temperature.

7.2 Use aging ovens that conform to the requirements of Type I of Specification [D5423](#).

8. Test Specimen

8.1 The accuracy of the test results depends significantly upon the number of specimens exposed at each temperature and the dispersion of the test results. The larger the individual deviations from the mean, the greater is the number of test specimens needed to achieve satisfactory accuracy. Experience has shown that a minimum of five test specimens needs to be used at each exposure temperature. A separate group of test specimens is required for each exposure period.

8.2 It is possible that the rate of deterioration will be significantly influenced by specimen thickness. Consequently

TABLE 1 Temperature and Exposure Time in Days

Exposure Temperature, °C	Estimated Hottest-Spot Temperature Range, °C				
	100 to 120	125 to 145	150 to 170	175 to 195	200 to 240
300	10
290	20
280	40
270	70
260	140
250	10	280
240	20	490
230	40	...
220	10	70	...
210	20	140	...
200	...	10	40	280	...
190	...	20	70	490	...
180	10	40	140
170	20	70	280
160	40	140	490
150	70	280
140	140	490
130	280
120	490

it is important to test specimens of the same nominal thickness when comparing the thermal degradation of two or more materials unless information relating degradation to thickness is available that indicates the contrary. This test method specifies the specimen size, including thickness, for each property selected.

PROCEDURES

9. Oven Aging (Thermal Exposure)

9.1 Factors such as moisture, chemical contamination, and mechanical stress or vibration usually do not in themselves cause failure, but are factors that have the potential to result in failure only after the material has been weakened by thermal deterioration. For this reason, exposure to elevated temperatures is the primary deteriorating influence considered in this test method.

9.2 **Table 1** is intended as a guide for the selection of thermal exposure. Select times and temperatures from those given in this table. The exposure times given are approximately equal to the average estimated life at each exposure temperature based on thermal aging data obtained on insulating materials and systems. It is recognized that the potential exists that this table will be revised as a result of experience. The potential that either the time or the temperature will be adjusted to make the best use of available oven facilities.

9.3 Age at a minimum of three and preferably four temperatures. Choose the lowest temperature to be less than 25°C above the hottest-spot temperature expected in use so that the thermal life is at least 5000 h. Select the highest temperature so that the thermal life is at least 100 h. If possible, the aging temperatures needs to differ from each other by at least 20°C.

9.4 It is possible that the selection of the appropriate aging temperatures for an unknown material will require a short exploratory test performed at the highest likely aging tempera-

ture. Results from thermal aging tests for a material with similar composition have the potential to provide clues for an appropriate selection of the first exploratory temperature. The chemical composition of the material to be tested, if known, has the potential to also provide a means for estimating the first aging temperature to be used. Additional tests can then be made at lower or higher temperatures as indicated by the first exploratory test. (See **Table 1** and **9.3**.)

9.5 Place a sufficient number of specimens to conduct the tests used for the selected aging criterion in each aging oven. Remove all of the test specimens after a selected interval of time. (See **9.6**.) Select the test specimens needed for the test at random. Return the remaining samples to the aging oven and repeat the process after each succeeding time interval (aging period).

9.6 Suggested total exposure times with associated test temperatures are given in **Table 1**. Initially, at least seven, evenly-spaced, test intervals at each test temperature are usually needed to provide sufficient data for the thermal life curves. (It is wise to provide sufficient specimens for ten intervals.) It is most important to adequately define the later portion of the thermal life curve. With experience, it is possible that fewer test specimens and time intervals will be needed. At the start, place only about half of the test specimens in the aging oven. Then use a relatively long, initial aging period. The test results after this initial aging period can provide guidance for subsequent time intervals for the remaining specimens in the oven. Then place the so-far, unaged specimens in the oven or withhold for an even longer period as suggested by the test results.

10. Dielectric Strength

10.1 Apparatus:

10.1.1 A testing device shall be employed whereby the test specimen is clamped under pressure between elastomeric gaskets to prevent flashover during the measurement. A suitable apparatus and details of the electrode assembly used in this apparatus are illustrated in **Fig. 1**.

10.1.2 The test assembly shall consist of an upper electrode holder, 2, which is stationary, and a movable lower electrode holder, 6. Each holder shall contain a 19-mm (³/₄-in.) diameter electrode, 11, with edges rounded to a radius of 3.18 mm (¹/₈ in.). An elastomeric gasket, 12, shall surround each electrode, allowing approximately 1.59-mm (¹/₁₆-in.) circumferential clearance between the gasket and the electrode. The specimen, 5, shall be placed between the electrodes, which shall be spring-loaded, 10, to provide 2.22-N (¹/₂-lbf) electrode pressure. Application of compressed air, controlled by a regulator, 9, to the air cylinder, 8, causes the lower electrode assembly to move upward against the specimen. The specimen is thus sealed between the holders by the elastomeric gaskets.

10.1.3 The holders shall be constructed from suitable electrical insulating materials.

NOTE 1—Polyethylene is suggested for room-temperature tests. Ceramic or silicone-glass are optional materials for use for elevated-temperature tests.

10.1.4 The gaskets shall be made from sheets of uncured silicone rubber of the highest track resistance available. These

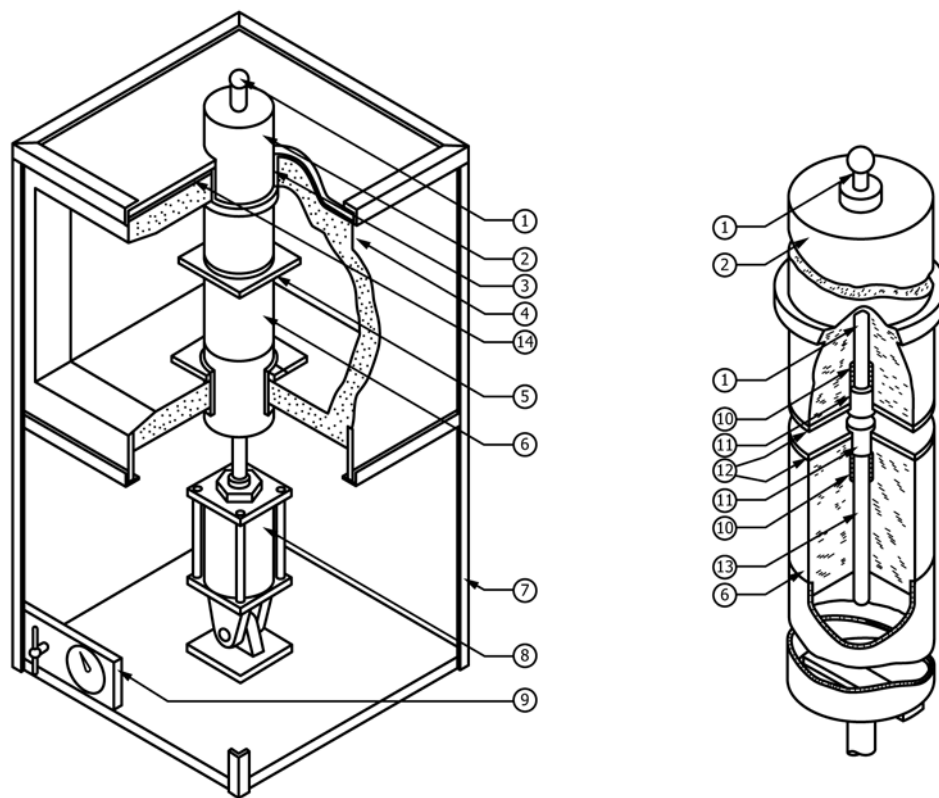

- | | |
|---|------------------------------------|
| 1. Upper Electrode Connecting Rod—With Sphere Top | 8. Air Cylinder |
| 2. Upper Electrode Holder | 9. Air Regulator |
| 3. Bearing Ring | 10. Spring for Loading Electrode |
| 4. Grounded Shield | 11. Cylinder Electrode |
| 5. Test Specimen | 12. Elastomeric Gasket |
| 6. Movable Lower Electrode Holder | 13. Lower Electrode Connecting Rod |
| 7. Skeleton Frame | 14. Top Plate (Bearing Plate) |

FIG. 1 Test Assembly, Dielectric Strength Transverse-Air-Rigid Specimen

shall be molded in place between the holders under pressure and cured by application of heat.

10.1.5 The apparatus shall be so constructed that the bearing pressure is transmitted to an angle iron frame, 7, by means of a bearing ring, 3, and a top plate, 14. Sheet metal, 4, or metal lath shall be used to protect the operator from high voltage.

NOTE 2—The construction described allows placing the electrodes inside a standard oven for tests at elevated temperature if desired. The oven wall replaces the metal guard, 4. The only modification to the oven that is required is cutting holes through the top and bottom for the electrode holders.

10.1.6 The electrode connecting rods, 1 and 13, shall be tapped into the electrodes for ease of disassembly when it is necessary to clean the electrodes by machining.

10.1.7 The dimensions of the holders and clearance distances are determined by the highest voltage that is desired. A practical working assembly used up to 60 kV has the following dimensions:

10.1.7.1 The holders and gaskets are 120.7 mm (4¾ in.) in diameter.

10.1.7.2 The electrodes are mounted inside an oven, the inside dimensions of which are 381 by 356 by 292 mm (15 by 14 by 11½ in.).

10.1.7.3 The closest air-gap distance from the holder insulation to the ground inside the oven is 127 mm (5 in.).

10.1.7.4 The closest air-gap distance from the sphere attached to the high-voltage electrode connecting rod to a ground is 254 mm (10 in.).

10.2 Test Specimens:

10.2.1 The test specimens shall be 152-mm (6-in.) squares cut from nominal 1.58-mm (1/16-in.) thick sheets, or shall be 152-mm diameter disks molded to a nominal 1.58 mm thickness.

10.2.2 Five or more specimens per exposure interval shall be used for each temperature as selected in accordance with Section 8.

10.2.3 Screen all specimens by applying 12 000 V for 1 min. Specimens that fail the screening test shall be discarded.

10.3 Procedure:

10.3.1 Test for electric strength in accordance with Methods D149.

10.3.2 Obtain the thickness of each test specimen at or near its center and record.

10.3.3 Condition five or more specimens for 48 h in the Standard Laboratory Atmosphere ($23 \pm 1.1^\circ\text{C}$, 50 % relative humidity).

10.3.4 Measure the breakdown voltage of each of five or more specimens at room temperature, using the pressure electrodes, by applying voltage at the rate of 0.5 kV/s. Calculate and record the electric strength in kV/mm (V/mil) (breakdown voltage divided by thickness in millimetres or mils). (**Warning**—Lethal voltages are a potential hazard during the performance of this test. It is essential that the test apparatus, and all associated equipment that has the potential to be electrically connected to it, be properly designed and installed for safe operation. Solidly ground all electrically conductive parts which it is possible for a person to contact during the test. Provide means for use at the completion of any test to ground any parts which were at high voltage during the test or have the potential for acquiring an induced charge during the test or retaining a charge even after disconnection of the voltage source. Thoroughly instruct all operators as to the correct procedures for performing tests safely. When making high voltage tests, particularly in compressed gas or in oil, it is possible for the energy released at breakdown to be sufficient to result in fire, explosion, or rupture of the test chamber. Design test equipment, test chambers, and test specimens so as to minimize the possibility of such occurrences and to eliminate the possibility of personal injury. If the potential for fire exists, have fire suppression equipment available.)

10.3.5 Place approximately 50 specimens, or ten times the number of specimens used for each exposure interval, in the aging oven maintained at the selected temperature. At the end of the first exposure interval, remove five or more specimens and allow to cool for 2 h in the Standard Laboratory Atmosphere.

10.3.6 Test the specimens as in 10.3.4.

10.3.7 Remove the same number of specimens again at the end of another exposure interval; allow to cool for 2 h as in 10.3.5.

10.3.8 Test the specimens again as in 10.3.4.

10.3.9 Repeat until all specimens are tested or until it is judged that dielectric strength has reached a practical minimum value. As the data are collected it is acceptable to indicate that specimens need not be tested at the end of such planned exposure interval but rather after two or more of the planned intervals. Make any adjustment that is deemed necessary to obtain the degradation rate.

10.3.10 Plot results with dielectric strength as ordinate and total elevated temperature aging time as abscissa. (A log abscissa is recommended.)

11. Flexural Strength

11.1 *Apparatus*—A testing machine, loading nose, and supports conforming to the requirements of Test Methods D790.

11.2 *Test Specimen*:

11.2.1 The test specimen shall be 76 by 25 by 3 mm (3 by 1 by $\frac{1}{8}$ in.) in nominal thickness.

11.2.2 Specimens obtained from laminated plastics shall all be cut from the same direction of the sheet, lengthwise or crosswise. Where the direction cannot easily be determined,

preliminary room-temperature tests shall be made. The direction exhibiting the greater flexural strength shall be considered the lengthwise direction. This corresponds to the warp direction of woven fabrics or to the machine direction for papers.

11.2.3 Use five or more specimens per exposure period for each temperature as selected in accordance with Section 9.

11.3 *Procedure*—Measure flexural strength flatwise in accordance with Test Method D229. Load the specimen on a 50-mm (2-in.) span.

11.3.1 Obtain the thickness of each test specimen and record.

11.3.2 Obtain the flexural strength of each of five or more specimens in accordance with Test Method D229 and record.

11.3.3 Place approximately 50 specimens, or ten times the number of specimens used for each exposure interval, in the aging oven maintained at the selected temperature. At the end of the first exposure interval, remove five or more specimens and allow to cool to room temperature for 2 h.

11.3.4 Test the specimens as in 11.3.2.

11.3.5 Remove the same number of specimens again at the end of another exposure interval; allow to cool to room temperature for 2 h.

11.3.6 Test the specimens as in 11.3.2.

11.3.7 Repeat until all specimens are tested or until it is judged that flexural strength has reached a practical minimum value. As the data are collected, it is acceptable to indicate that specimens need not be tested at the end of each planned exposure period but rather after two or more of the planned exposure intervals. Make any adjustment that is deemed necessary to obtain the degradation rate.

11.3.8 Plot results with flexural strength as ordinate and total elevated temperature aging time as abscissa. (A log abscissa is recommended.)

12. Water Absorption

12.1 *Apparatus*—An analytical balance and oven as described in Test Method D570 and a desiccator.

12.2 *Test Specimen*:

12.2.1 The test specimen shall be 76 by 25 by 3 mm (3 by 1 by $\frac{1}{8}$ in.) nominal thickness.

12.2.2 Use five or more specimens per exposure period for each temperature as selected in accordance with Section 9.

12.3 *Procedure*:

12.3.1 Measure water absorption in accordance with Test Method D570. Condition specimens for 1 h at 105 to 110°C and allow to cool in a desiccator for 2 h at room temperature before weighing, except remove thermally aged specimens from the oven directly to the desiccator and weigh after 2 h of cooling. Use the procedure requiring 24 h immersion in water at 23°C. Unless it has been demonstrated that the test material contains negligible water-soluble matter, determine the water-soluble matter.

12.3.2 Measure the water absorption of each of five or more specimens.

12.3.3 Place approximately 50 specimens, or ten times the number of planned exposure intervals, in the aging oven maintained at the selected temperature. At the end of the first

exposure interval, remove five or more specimens and place directly in a desiccator to cool to room temperature for 2 h.

12.3.4 Measure the water absorption as in 12.3.2.

12.3.5 Remove five or more specimens again at the end of the next exposure interval and allow to cool in a desiccator as previously.

12.3.6 Test the specimens as in 12.3.2.

12.3.7 Repeat until all specimens are tested or until it is judged that water absorption has reached a practical maximum value. As the data are collected, it is acceptable to indicate that specimens need not be tested at the end of each planned exposure interval but rather after two or more of the planned exposure periods. Any adjustment that is deemed necessary to obtain the degradation rate shall be used.

12.3.8 Plot results with water absorption as ordinate and total elevated temperature aging times as abscissa. (A log abscissa is recommended.)

13. Calculation

13.1 For each temperature establish the thermal-life curve best fitting the plot of the average value of the selected aging criterion—dielectric strength, flexural strength or water absorption. Determine from this plot the number of hours corresponding to the value of the selected end point in accordance with 6.1 and 6.3—the thermal life.

13.1.1 Show all of the experimental points on the thermal-life curve. A best fitting plot by eye is often acceptable without the use of statistical procedures. Interest lies in the later part of the curve which includes the end point. Scatter of test results in the early part of the thermal-life curve is not important. If considerable scatter of the experimental points occurs, it is often possible to use simple statistical procedures to arrive at a suitable probable average value. If a best fitting plot cannot be obtained by eye, statistical procedures will probably need to be used with caution, but it is probably prudent to repeat the test in this case.

13.2 Record the values of thermal life at each exposure temperature on graph paper with the logarithm of time as the ordinate and the reciprocal of the absolute temperature, $1/K$, as the abscissa. The scale for the abscissa is often plotted from right to left with values in °C. Construct such graph paper by hand or with a suitable computer program. Special graph papers for this purpose are also potentially available for purchase and can be used if the scales are suitable.

13.2.1 It is often acceptable to plot by eye values of thermal life as a straight line—the Arrhenius plot. Sometimes a straight line can be plotted just through three points at the lower temperatures. In such case it is acceptable to disregard the value at the higher temperature. If a pronounced curvature exists in the plot, it is possible that it will be necessary to obtain data at an additional lower aging temperature. When reasonable linearity is obtained, it is acceptable to use the statistical procedures described in IEEE 101 which provide a means for computing the plot by regression analysis with the lower 95 % confidence limit.

13.2.2 Determine the temperature index from the Arrhenius plot as the value on the temperature scale at which the extrapolated line crosses the specified value of time, usually 20 000 h. This index is recorded as a simple number, not as °C.

14. Report

14.1 Report the following information:

14.1.1 A description of the material,

14.1.2 Any special treatment or conditioning of the material,

14.1.3 The aging criteria used and the ambient, if other than air,

14.1.4 The dimensions of the test specimen used for each aging criterion,

14.1.5 The unaged test results for each aging criterion used,

14.1.6 The end point used for the thermal life curves,

14.1.7 A thermal life curve for each aging temperature,

14.1.8 The thermal-endurance graph with confidence limits (if determined),

14.1.9 The value of time used in the determination of the temperature index, and

14.1.10 The value of the temperature index.

15. Precision and Bias

15.1 The precision of this test method has not been determined. A statement of bias is not applicable because a standard reference material is not available.

16. Keywords

16.1 a-c breakdown voltage; flexural strength; heat aging; rigid plates; rigid sheets; thermal endurance; thermosetting laminates; water absorption

REFERENCES

- (1) Winans, R. R., and Hand, W., “Electrical Properties of Thermosetting Plastics at Elevated Temperatures.” *Symposium on Temperature Stability of Electrical Insulating Materials*, ASTM STP 161, Am. Soc. Testing Mats., 1954, p. 59.
- (2) Power, G. E., “Appraisal of High Temperature Behavior of Laminates with Time,” *IEEE CP 55–234*, Inst. Electrical and Electronic Engrs., 1955.
- (3) Kouwenhoven, W. B., Knickerbocker, G. G., and Wechsler, K., “Thermal Stability of Laminated Thermosetting Plastics,” *IEEE CP 57–141*, Inst. Electrical and Electronic Engrs., 1957.
- (4) Wechsler, K., “The Evaluation of Thermal Endurance of Rigid Electrical Insulation,” Third Annual Conference on Application of Electrical Insulation, IEEE-NEMA, Chicago, Ill., Dec. 5–8, 1960.
- (5) “IEC 216 Guide for the Determination of Thermal Endurance Properties of Electrical Insulating Materials (Parts 1, 2, 3, and 4)” American National Standards Institute, 1430 Broadway, New York, NY 10018.
- (6) “UL 746B Polymeric Materials—Long Term Properties Evaluations.” Underwriters Laboratories Inc., 33 Pfingsten Rd., Northbrook, IL 60062.

ASTM International takes no position respecting the validity of any patent rights asserted in connection with any item mentioned in this standard. Users of this standard are expressly advised that determination of the validity of any such patent rights, and the risk of infringement of such rights, are entirely their own responsibility.

This standard is subject to revision at any time by the responsible technical committee and must be reviewed every five years and if not revised, either reapproved or withdrawn. Your comments are invited either for revision of this standard or for additional standards and should be addressed to ASTM International Headquarters. Your comments will receive careful consideration at a meeting of the responsible technical committee, which you may attend. If you feel that your comments have not received a fair hearing you should make your views known to the ASTM Committee on Standards, at the address shown below.

This standard is copyrighted by ASTM International, 100 Barr Harbor Drive, PO Box C700, West Conshohocken, PA 19428-2959, United States. Individual reprints (single or multiple copies) of this standard may be obtained by contacting ASTM at the above address or at 610-832-9585 (phone), 610-832-9555 (fax), or service@astm.org (e-mail); or through the ASTM website (www.astm.org). Permission rights to photocopy the standard may also be secured from the Copyright Clearance Center, 222 Rosewood Drive, Danvers, MA 01923, Tel: (978) 646-2600; <http://www.copyright.com/>