



Designation: D2300 – 08 (Reapproved 2017)

Standard Test Method for Gassing of Electrical Insulating Liquids Under Electrical Stress and Ionization (Modified Pirelli Method)¹

This standard is issued under the fixed designation D2300; the number immediately following the designation indicates the year of original adoption or, in the case of revision, the year of last revision. A number in parentheses indicates the year of last reapproval. A superscript epsilon (ϵ) indicates an editorial change since the last revision or reapproval.

1. Scope

1.1 This test method measures the rate at which gas is evolved or absorbed by insulating liquids when subjected to electrical stress of sufficient intensity to cause ionization in cells having specific geometries.

1.2 This test method is not concerned with bubbles arising from supersaturation of the insulating liquid.

1.3 *This standard does not purport to address all of the safety concerns, if any, associated with its use. It is the responsibility of whoever uses this standard to consult and establish appropriate safety and health practices and determine the applicability of regulatory limitations prior to use.* For specific precautions see 5.1.4 and 8.4.

2. Referenced Documents

2.1 *ASTM Standards:*²

D924 Test Method for Dissipation Factor (or Power Factor) and Relative Permittivity (Dielectric Constant) of Electrical Insulating Liquids

3. Summary of Test Method³

3.1 After being saturated with a gas (usually hydrogen), the insulating liquid is subjected to a radial electrical stress. The gas space above the insulating liquid film is ionized due to the electrical stresses and therefore the insulating liquid surface at the insulating liquid-gas interface is subjected to ionic bombardment. The evolving or absorbing of gas is calculated in

¹ This test method is under the jurisdiction of ASTM Committee D27 on Electrical Insulating Liquids and Gases and is the direct responsibility of Subcommittee D27.05 on Electrical Test.

Current edition approved Jan. 1, 2017. Published February 2017. Originally approved in 1968. Last previous edition approved in 2008 as D2300 - 08. DOI: 10.1520/D2300-08R17.

² For referenced ASTM standards, visit the ASTM website, www.astm.org, or contact ASTM Customer Service at service@astm.org. For *Annual Book of ASTM Standards* volume information, refer to the standard's Document Summary page on the ASTM website.

³ The original Pirelli method is described by Guiseppa Palandri and Ugo Pellagatti in the paper, "Gli Oli Isolanti per Cavi Elettrici" (Insulating Oils for Electric Cables), *Elettrotecnica* (Milan) Jan. 8, 1955. Translation of this paper is contained in "Minutes of the Meeting of the Insulated Conductors Committee of the American Institute of Electrical Engineers," Nov. 15 and 16, 1955.

volume per unit of time from changes in pressure with time from two specimens run on the same sample.

3.2 This test method indicates whether insulating liquids are gas absorbing or gas evolving under the test conditions.

4. Significance and Use

4.1 For certain applications when insulating liquid is stressed at high voltage gradients, it is desirable to be able to determine the rate of gas evolution or gas absorption under specified test conditions. At present time correlation of such test results with equipment performance is limited.

4.2 In this test method, hydrogen (along with low molecular weight hydrocarbons) is generated by ionic bombardment of some insulating liquid molecules and absorbed by chemical reaction with other insulating liquid molecules. The value reported is the net effect of these two competing reactions. The aromatic molecules or unsaturated portions of molecules present in insulating liquids are largely responsible for the hydrogen-absorbing reactions. Both molecule type, as well as concentration, affects the gassing tendency result. Saturated molecules tend to be gas evolving. The relation between aromaticity and quantity of unsaturates of the insulating liquid and gassing tendency is an indirect one and cannot be used for a quantitative assessment of either in the insulating liquid.

4.3 This test method measures the tendency of insulating liquids to absorb or evolve gas under conditions of electrical stress and ionization based on the reaction with hydrogen, the predominant gas in the partial discharge. For the test conditions, the activating gas hydrogen, in contrast to other gases, for example, nitrogen, enhances the discrimination of differences in the absorption-evolution patterns exhibited by the insulating liquids. Insulating liquids shown to have gas-absorbing (H_2) characteristics in the test have been used to advantage in reducing equipment failures, particularly cables and capacitors. However, the advantage of such insulating liquids in transformers is not well defined and there has been no quantitative relationship established between the gassing tendency as indicated by this test method and the operating performance of the equipment. This test method is not concerned with bubble evolution, which may arise from physical processes associated with super-saturation of gases in oil or water vapor bubbles evolving from wet insulation.

5. Apparatus

5.1 The apparatus for making gassing tests where the insulating liquid is saturated in the same cell that is used thereafter to electrically stress the insulating liquid is shown in Fig. 1. The apparatus consists of the following:

5.1.1 *Gassing Cell and Buret Assembly*, as shown in Fig. 1, with dimensions as given in Fig. 2. The gassing cell consists of the following two components:

5.1.1.1 Cell made of borosilicate glass with the part under stress constructed of 16 mm inside diameter and 18 mm outside diameter truebore tubing. This cell has an outer (ground) electrode of painted or plated silver with a vertical slit for observing the insulating liquid level, and a metal conductor band for ground connection.

5.1.1.2 *Hollow High-Voltage Electrode* made of 10 ± 0.1 -mm outside diameter center-less-ground and polished No. 304 stainless steel seamless tubing and containing an 18-gage stainless steel capillary tubing as a gas passage. The electrode shall be supported and centered by a precision-machined 24/40 recessed TFE-fluorocarbon plug. A $\frac{1}{8}$ -in. needle valve (*E*) with gas inlet is on top of the electrode.

5.1.2 *Gas Buret* (Fig. 1) made of 7-mm outside diameter borosilicate glass tubing with an etched scale, tapered glass joint (*G*) for connecting to the gassing cell, a bypass stopcock (*D*), and three glass bulbs, (*A*, *B*, and *C*).

5.1.3 *Oil Bath* with thermostatic control to maintain the bath at test temperature $\pm 0.5^\circ\text{C}$. The bath shall be equipped with a stirrer, a heating arrangement capable of maintaining the necessary temperature control, a suitable support for the gassing test cell assembly, and a thermometer graduated in 0.1°C divisions. As the test is temperature sensitive, it is important that the calibration is traceable to a standard, such as NIST.

5.1.4 *Transparent Safety Shield* to protect the operator from contact with high voltage.

5.1.5 *High-Voltage Transformer*, providing a test voltage having a frequency in the range of 45 to 65 Hz. The

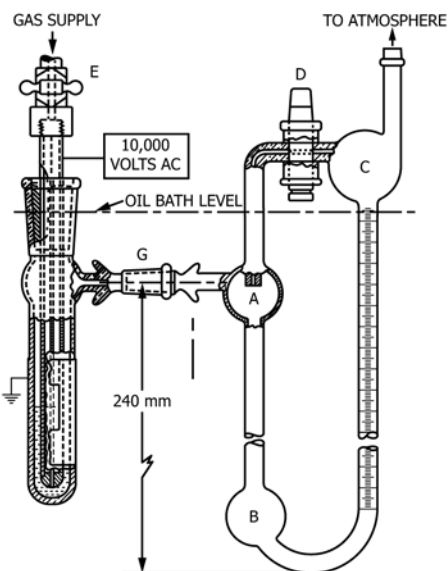

FIG. 1 Schematic Diagram of Cell and Manometer Assembly

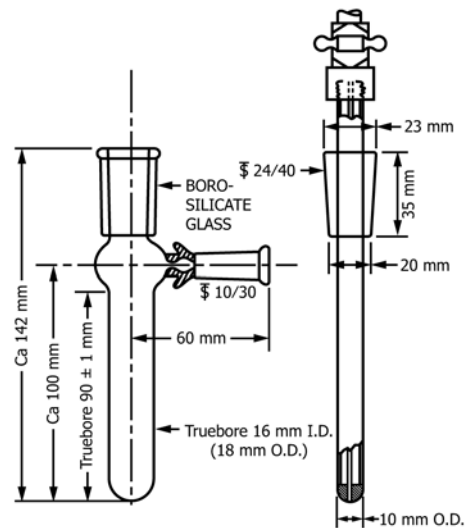

FIG. 2 Detailed Dimensions of the Glass Cell and the Inner (High-Voltage) Electrode

transformer and its controlling equipment shall be of such size and design that with the test specimen in the circuit, the voltage wave shape shall approximate a sinoid with both half cycles closely alike. The ratio of peak-to-rms values should be equal to the square root of two within $\pm 5\%$ while maintaining $10 \text{ RV} \pm 2\%$.

6. Reagents and Materials

6.1 *Hydrogen*, oxygen-free. See Note 1.

6.2 *Dibutyl Phthalate*, reagent grade.

6.3 *2-Propanol*, reagent grade.

6.4 Low vapor pressure grease, such as high vacuum silicone grease.

6.5 Unless otherwise indicated, it is intended that all reagents shall conform to the Committee on Analytical Reagents of the American Chemical Society.

NOTE 1—Hydrogen normally is the saturating gas but other gases, such as nitrogen, carbon dioxide, argon, or air may be used.

7. Preparation of Apparatus

7.1 Clean the glass cell by first rinsing it inside and outside with a suitable hydrocarbon solvent such as heptane or other solvent suitable for the dielectric liquid test tested. Then fill the cell with the hydrocarbon solvent and scrub to remove waxy deposits from previous tests. Clean the tapered joint, taking care that none of the grease enters the cell. Again rinse with hydrocarbon solvent and blow dry with clean compressed air. Check the silver electrode and repair if necessary.

7.2 Clean the hollow electrode by blowing a suitable hydrocarbon solvent through the capillary tube with compressed air, rinsing the insulating liquid off the entire electrode with a suitable hydrocarbon solvent, such as heptane, and wiping off any waxy deposit with tissue paper. Polish the surface with a 2-propanol soaked towel. If there are visible marks on the stainless steel shaft of the electrode, they should be polished with a suitable device, such as a buffing wheel, wiping off the

buffing compound carefully with tissue paper moistened with a suitable hydrocarbon solvent such as heptane.

7.3 Apply a light coat of low vapor pressure silicone grease to the stopcock (*D*) and the standard-taper joint (*G*) and assemble the glass cell and buret, but do not insert the electrode into the glass cell.

7.3.1 **Caution:** Do not allow silicone grease to contaminate the inside of the buret, gassing cell, electrode, or oil.

7.4 Fill the buret to the half-full mark with dibutyl phthalate.

8. Procedure

8.1 Introduce 5 ± 0.1 mL of the insulating liquid sample into the glass cell by means of a hypodermic syringe.

8.2 Lightly coat the TFE-fluorocarbon plug of the electrode with the test insulating liquid or low vapor pressure silicone grease and insert the electrode into the glass cell.

NOTE 2—It has been found helpful to place a few drops of the test insulating liquid on top of the TFE-fluorocarbon plug to act as a gas-seal. If there is a leak, use of the oil may help detect it through the appearance of gas bubbles at the top of the Teflon plug.

8.3 Bring the oil bath up to 80°C (for some applications it may be desirable to use 60°C; in either case, report test temperature as indicated in 10.1.1). Suspend the gassing cell and buret assembly in the oil bath at the level indicated in Fig. 1, and connect the lead from the outside electrode to ground.

8.4 Attach the gas inlet and outlet connections. When using hydrogen, the gas outlet should lead outside the building, either directly or through a fume hood.

8.5 Close the stopcock (*D*) and open the valve (*E*) to allow the saturating gas to bubble through the test insulating liquid and the buret liquid at a steady rate (about 3 bubbles/s) for 10 min.

8.6 Open the stopcock (*D*) and continue bubbling the saturating gas through the test insulating liquid for an additional 5 min.

8.7 After a total of 15 min of gas bubbling, close the *first* valve (*E*) and *then* the stopcock (*D*), making certain the liquid levels in the two legs of the buret are equal.

8.8 Connect the high-voltage lead to the center electrode.

8.9 Place the transparent safety shield in position and take the buret reading after checking the bath temperature.

NOTE 3—To facilitate reading the buret, it has been found helpful to illuminate the buret scale and to use a magnifying glass or a small optical magnifying device.

8.10 Turn on the high voltage and adjust to 10 kV. Record the time and voltage, as well as the buret level, and check the observation slit on the outer electrode for onset of the gassing reaction.

8.11 After 10 min, record the buret level, voltage, and bath temperature.

8.12 After an additional 50 min, again record the buret level, voltage, and bath temperature, and turn off the voltage.

8.13 To ensure the equipment is operating correctly it is recommended that the buret level be read every 10 min until

the test is terminated. A plot of the readings versus time should give a reasonably straight line. If the data are widely scattered, the equipment should be checked and the test rerun.

8.14 For oils with very low gassing tendencies, it may be necessary to stop the test to vent the manometer. The total gas absorbed is the sum of the gas absorbed before and after venting.

8.15 Repeat the procedure on a fresh test specimen, 8.1 – 8.13.

9. Calculation

9.1 Calculate the gassing tendency as follows:

$$G = (B_{60} - B_{10})K/T$$

where:

G = gassing tendency, $\mu\text{L}/\text{min}$,

B_{60} = buret reading, mm, at 60 min of test,

B_{10} = buret reading, mm, at 10 min of test,

K = buret constant = $\mu\text{L}/\text{mm}$ buret reading, (see Appendix X2) and

T = test time of computed gassing rate, min = 60 – 10 = 50 min.

NOTE 4—This will result in an answer which will be positive (+) if gas is evolved, and negative (–) if gas is absorbed.

9.2 Take the average of the two values of G . If the average values are different by more than $0.3 + 0.26 |X|$, then the test should be repeated. Where $|X|$ is the absolute value of duplicate determinations in microlitres per minute. Duplicate analyses are performed because it is difficult to detect when a problem occurs during a test. The equation to determine when duplicate analysis are acceptable is based on general experiences and is not derived from a round-robin program for this test method.

9.3 See Appendix X1 to determine the electrical stress for the electrode system and dielectric liquids.

10. Report

10.1 Report the following:

10.1.1 Test temperature,

10.1.2 Test voltage and frequency,

10.1.3 Saturating gas,

10.1.4 Test period, and

10.1.5 Average gassing rate in microlitres per minute.

11. Precision and Bias

11.1 The precision of this test method is based on an interlaboratory study of D2300-01, Standard Test Methods for Gassing of Electrical Insulating Liquids Under Electrical Stress and Ionization (Modified Pirelli Method), conducted in 2006. One laboratory tested two different materials. Every “test result” represents the average of two determinations. The laboratory obtained ten replicate test results for each material.⁴ See Table 1.

11.1.1 *Repeatability*—Two test results obtained within one laboratory shall be judged not equivalent if they differ by more

⁴ Supporting data are available from ASTM International Headquarters. Request RR:D27-1019.

TABLE 1 Gassing Rate ($\mu\text{L}/\text{min}$)

Material	Average \bar{x}	Repeatability Standard Deviation sr	Repeatability Limit r
Positive Gassing Oil	32.86	0.582	1.63
Negative Gassing Oil	-23.22	0.872	2.44

than the “ r ” value for that material; “ r ” is the interval representing the critical difference between two test results for the same material, obtained by the same operator using the same equipment on the same day in the same laboratory.

11.1.2 *Reproducibility*—Two test results shall be judged not equivalent if they differ by more than the “ R ” value for that material; “ R ” is the interval representing the difference between two test results for the same material, obtained by different operators using different equipment in different laboratories.

11.1.2.1 Reproducibility was not determined as part of this study.

11.1.3 Any judgment in accordance with these two statements would have an approximate 95 % probability of being correct.

11.2 *Bias*—At the time of the study, there was no accepted reference material suitable for determining the bias of this test method, therefore no statement on bias is being made.

11.3 The precision statement was determined through statistical examination of 20 results, from one laboratory, on two materials.

12. Keywords

12.1 gas absorbing; gas evolving; gassing; insulating liquids; insulating oils; ionization; Pirelli method

APPENDIXES

(Nonmandatory Information)

X1. CALCULATION OF ELECTRICAL STRESS

X1.1 The electrical stress on the insulating liquid in the cell can be calculated as follows:

$$G_x = \frac{1}{XK_1} \frac{V}{\frac{\ln d_2/d_1}{K_1} + \frac{\ln d_3/d_2}{K_2}}$$

where:

G_x = stress, kV/cm, at distance X in cm from axis of inner electrode,

V = applied voltage, in kV,

K_1 = dielectric constant of insulating liquid,

K_2 = dielectric constant of glass cylinder,

d_1 = diameter of the inner electrode,

d_2 = inner diameter of the outer glass cylinder, and
 d_3 = diameter of the outer glass cylinder.

X1.1.1 K_1 can be measured as outlined in Test Method D924. For most insulating mineral oils, the dielectric constant is approximately 2.2. For other insulating liquids, the dielectric constant may be different and characteristic values should be used.

X1.1.2 K_2 can best be determined on samples of the glass tubing by requesting such samples from the manufacturers of the cell when it is ordered. However, instead of an accurate determination a value of 5.3 for K_2 can be used with negligible effect on the numerical value of the calculated electrical stress.

X2. DETERMINATION OF BURET CONSTANT FOR MANOMETER, K

X2.1 Clean the manometer by rinsing with heptane or other suitable volatile hydrocarbon solvent. Dry in an oven at about 100°C for at least 2 hours.

X2.2 Hold the manometer in an upright position using a moveable, light-weight stand. Prepare to add distilled water using a syringe and needle attached to plastic tubing that fits tightly over the needle. The diameter of the tubing should allow it to easily fit into the manometer. A $1/32$ internal diameter with a $3/32$ outer diameter tubing has been found to be suitable. Push the plastic tubing into the manometer to the 7 cm mark and add the distilled water to about 7 cm mark. Avoid wetting the sides of the glass when the plastic tubing enters and is removed from the glass tubing of the manometer.

X2.3 Weight of the manometer and water. Record the weight as W_1 . Retain the manometer in the upright position all times to avoid wetting the sides.

X2.4 Add about 3 cm of heptane using a separate syringe, needle and tubing again avoiding wetting the sides of the glass tubing.

X2.5 Weight the manometer and contents and record the weight as W_2 . Record the scale readings for the lowest (S_L) and highest (S_H) points of the heptane column, reading the lowest point of the meniscus.

X2.6 Calculate constant K in $\mu\text{L}/\text{cm}$ (unit scale reading) using the following:

$$K = \frac{(W_2 - W_1)10^3/G}{S_H - S_L}$$

where:

G = relative density (The relative density of the solvent used at the calibration temperature).

X2.7 Repeat the procedure X2.4 to X2.5 two times.

X2.8 Take the average of the three determinations for K . If the highest and lowest values determined for K do not agree within 5 percent of each other discard the results and repeat the procedure.

ASTM International takes no position respecting the validity of any patent rights asserted in connection with any item mentioned in this standard. Users of this standard are expressly advised that determination of the validity of any such patent rights, and the risk of infringement of such rights, are entirely their own responsibility.

This standard is subject to revision at any time by the responsible technical committee and must be reviewed every five years and if not revised, either reapproved or withdrawn. Your comments are invited either for revision of this standard or for additional standards and should be addressed to ASTM International Headquarters. Your comments will receive careful consideration at a meeting of the responsible technical committee, which you may attend. If you feel that your comments have not received a fair hearing you should make your views known to the ASTM Committee on Standards, at the address shown below.

This standard is copyrighted by ASTM International, 100 Barr Harbor Drive, PO Box C700, West Conshohocken, PA 19428-2959, United States. Individual reprints (single or multiple copies) of this standard may be obtained by contacting ASTM at the above address or at 610-832-9585 (phone), 610-832-9555 (fax), or service@astm.org (e-mail); or through the ASTM website (www.astm.org). Permission rights to photocopy the standard may also be secured from the Copyright Clearance Center, 222 Rosewood Drive, Danvers, MA 01923, Tel: (978) 646-2600; <http://www.copyright.com/>