



Designation: D2070 – 16<sup>ε</sup><sup>1</sup>

## Standard Test Method for Thermal Stability of Hydraulic Oils<sup>1</sup>

This standard is issued under the fixed designation D2070; the number immediately following the designation indicates the year of original adoption or, in the case of revision, the year of last revision. A number in parentheses indicates the year of last reapproval. A superscript epsilon ( $\epsilon$ ) indicates an editorial change since the last revision or reapproval.

<sup>ε</sup><sup>1</sup> NOTE—The formatting of footnotes was corrected editorially in April 2017.

### 1. Scope\*

1.1 This test method<sup>2</sup> is designed primarily to evaluate the thermal stability of hydrocarbon based hydraulic oils although oxidation may occur during the test.

1.2 The values stated in SI units are to be regarded as standard. No other units of measurement are included in this standard.

1.3 *This standard does not purport to address all of the safety concerns, if any, associated with its use. It is the responsibility of the user of this standard to establish appropriate safety and health practices and determine the applicability of regulatory limitations prior to use.*

1.4 *This international standard was developed in accordance with internationally recognized principles on standardization established in the Decision on Principles for the Development of International Standards, Guides and Recommendations issued by the World Trade Organization Technical Barriers to Trade (TBT) Committee.*

### 2. Referenced Documents

- 2.1 *ASTM Standards:*<sup>3</sup>  
[D4057 Practice for Manual Sampling of Petroleum and Petroleum Products](#)
- 2.2 *Copper Development Association Standard*<sup>4</sup>  
[UNS C11000 Electrolytic Tough Pitch Copper](#)
- 2.3 *American Iron and Steel Institute Standard (AISI)*<sup>5</sup>  
[W-1 Carbon Tool Steel](#)

<sup>1</sup> This test method is under the jurisdiction of ASTM Committee D02 on Petroleum Products, Liquid Fuels, and Lubricants and is the direct responsibility of Subcommittee D02.N0 on Hydraulic Fluids.

Current edition approved Dec. 15, 2016. Published January 2017. Originally approved in 1991. Last previous edition approved in 2010 as D2070 – 91(2010). DOI: 10.1520/D2070-16E01.

<sup>2</sup> This procedure was adopted from the Fives Cincinnati Thermal Stability Test Procedure “A”, Fives Cincinnati Manual 10-SP-89050.

<sup>3</sup> For referenced ASTM standards, visit the ASTM website, [www.astm.org](http://www.astm.org), or contact ASTM Customer Service at [service@astm.org](mailto:service@astm.org). For *Annual Book of ASTM Standards* volume information, refer to the standard’s Document Summary page on the ASTM website.

<sup>4</sup> Available from Copper Development Assoc., Inc., 260 Madison Ave., New York, NY 10016, <http://www.copper.org>.

<sup>5</sup> Available from American Iron and Steel Institute (AISI), 25 Massachusetts Ave., NW, Suite 800, Washington, DC 20001, <http://www.steel.org>.

### 3. Summary of Test Method

3.1 A beaker containing test oil, copper and iron rods is placed in an aluminum block in an electric gravity convection oven for 168 h at a test temperature of 135 °C. At the completion of the test, the copper and steel rods are rated visually for discoloration and the oil is analyzed for the quantity of sludge.

### 4. Significance and Use

4.1 Thermal stability characterizes physical and chemical property changes which may adversely affect an oil’s lubricating performance. This test method evaluates the thermal stability of a hydraulic oil in the presence of copper and steel at 135 °C. Rod colors are the evaluation criteria. Sludge values are reported for informational purposes. No correlation of the test to field service has been made.

### 5. Apparatus

5.1 An aluminum block with equally spaced holes is used. An example is described in [Fig. A1.1](#) of [Annex A1](#).

5.2 Electric gravity convection oven capable of maintaining the aluminum block at a test temperature of 135 °C ± 1 °C.

5.2.1 Calibrated thermocouple and temperature indicator centered in aluminum block.

5.3 250 mL Griffin beakers of borosilicate glass.

5.4 Copper test specimens are to be UNS C11000, 99.9 % pure electrolytic tough pitch copper, 6.35 mm in diameter by 7.6 cm in length (0.25 in. by 3.0 in.).<sup>6,7</sup>

5.5 Steel test specimens are to be AISI W-1 1 % carbon steel, 6.35 mm in diameter 7.6 cm in length (0.25 in. by 3.0 in.).<sup>6,7</sup>

5.6 Silicon carbide abrasive 320 grit with cloth backing.

5.7 Crocus cloth.

<sup>6</sup> The sole source of supply of the apparatus known to the committee at this time is Metaspec LLC, 790 W. Mayfield Blvd., San Antonio, TX 78211, [metaspec@earthlink.net](mailto:metaspec@earthlink.net).

<sup>7</sup> If you are aware of alternative suppliers, please provide this information to ASTM International Headquarters. Your comments will receive careful consideration at a meeting of the responsible technical committee,<sup>1</sup> which you may attend.

\*A Summary of Changes section appears at the end of this standard

5.8 41 Whatman filter paper,<sup>8,7</sup> 47 mm diameter.

5.9 Millipore filter,<sup>9,7</sup> 8 μm Type SC, 47 mm diameter.

5.10 Millipore glass filter holder, 47 mm, Cat #XX10.04700 or equivalent.

5.11 Fives Cincinnati Lubricant Heat Test Standards Color Chart.<sup>10,7</sup>

5.12 25 mL pipette.

## 6. Reagents

6.1 *Reagent Grade Heptane*—(**Warning**—Flammable. Health hazard.)

6.2 *Reagent Grade Acetone*—(**Warning**—Flammable. Health hazard.)

## 7. Preparation of Apparatus

7.1 Handle the rods at all times using forceps or clean cotton gloves.

7.2 *Catalyst Preparation*—Clean the iron and copper catalyst rods, whether new or previously used, prior to use. Clean the rods with the 320 silicon carbide abrasive cloth while rotating the rods in a drill chuck at 1700 r/min to 1800 r/min. Clean the surface until it has a bright copper or steel appearance. Discard rods when diameter is less than 6.2 mm.

7.3 Prepare surface finally with a crocus cloth. Remove all grind marks. Finish the rods to a lightly polished surface finish.

7.4 Wash the rods individually with acetone and air dry on completion of the polishing operation.

## 8. Procedure

8.1 Place a representative 200 mL sample of test oil obtained per **D4057** sampling procedure in a clean 250 mL Griffin beaker containing one each of the cleaned and polished iron and copper rods.

8.2 Place the rods totally below the surface of the oil and crossed. Place them in contact with each other at one point only.

8.3 Place the beaker and its contents in the pre-heated aluminum block test fixture in the oven.

8.4 Maintain the test fixture at 135 °C ± 1 °C for 168 h. Start the time when the test sample is placed in the oven.

8.5 Keep the oven doors closed during the entire test period. Monitor the temperature continuously via thermocouple in the center of the test block.

8.6 At the completion of 168 h, remove the beakers from the oven and allow to cool to room temperature before proceeding. Individually remove the rods from the oil sample. Remove any

loose sludge clinging to the rods with a plastic or rubber policeman and return the sludge to the oil.

8.7 *Copper Rod Analysis*—Wash the rod with heptane to remove all oil and allow to air dry. Discard the heptane wash. Make a visual evaluation of the condition of the rod against the Fives Cincinnati color chart (available from Fives Cincinnati<sup>9</sup>) and record.

8.8 *Steel Rod Analysis*—Wash the steel rod with heptane to remove all oil and allow to air dry. Discard the heptane wash. Make a visual evaluation of the rod against the Fives Cincinnati color chart and record.

8.9 For each sample, dry a 41 Whatman filter for 1 h in an oven at 70 °C and cool in a desiccator. Weigh to the nearest 0.1 mg. Vacuum filter at a nominal 26664 Pa pressure through the pre-weighed 41 Whatman filter. Do not rinse the beaker at this time. Remove the oil filtrate and set aside. Replace the filter flask with a clean one and wash all remaining residue from the beaker with heptane. Wash the residue on the filter paper with heptane until all evidence of oil is removed. Oven dry the residue and filter paper at 70 °C, 1 h, allow to cool, and weigh to nearest 0.1 mg. For each sample, pre-weigh an 8 μm Millipore filter pad to the nearest 0.1 mg. From the oil filtrate, pipet 25 mL of oil and vacuum filter at a nominal 26664 Pa pressure through the pre-weighed 8 μm Millipore filter pad. Wash residue with heptane, air dry, and weigh to the nearest 0.1 mg.

## 9. Calculation

9.1 *Total Sludge Determination*—The mass of the sludge on the 41 Whatman paper is reported as mg/100 mL of oil. Therefore, the mass of the original filter paper is subtracted from that of the dried filter paper plus residue and the difference divided by two. The mass of the sludge on the 8 μm Millipore filter pad is also reported as mg/100 mL. The mass of the original filter pad is subtracted from the mass of the dried residue plus filter pad and the difference multiplied by four. Total sludge is the summation of the mass of the sludge from the 41 Whatman filter paper plus the mass of the sludge from the 8 μm filter pad. Mass of total sludge (mg/100 mL of oil)

$$T = W \times 0.5 + M \times 4 \quad (1)$$

where:

$W$  = mass of sludge on Whatman filter in mg,

$M$  = mass of sludge on 8 μm millipore filter in mg,

$T$  = total mass of sludge in mg/100 mL.

## 10. Report

10.1 Report the color of the copper and steel rods as previously determined.

10.2 Report the total sludge in mg/100 mL oil.

## 11. Precision and Bias<sup>11</sup>

11.1 The precision of this test method was determined by a statistical analysis of interlaboratory test results. The following criteria should be used for judging the acceptability of data.

<sup>8</sup> The sole source of supply of the apparatus known to the committee at this time is Whatman Ltd., part of GE Healthcare, <http://www.whatman.com>.

<sup>9</sup> The sole source of supply of the apparatus known to the committee at this time is EMD Millipore Corp., 290 Concord Rd., Billerica, MA 01821; <http://www.EMDmillipore.com>.

<sup>10</sup> The sole source of supply of the apparatus known to the committee at this time is Fives Cincinnati, 2200 Litton Ln., Hebron, KY 41048; <http://www.fivesmsi.com>.

<sup>11</sup> Supporting data have been filed at ASTM International Headquarters and may be obtained by requesting Research Report RR:D02-1271. Contact ASTM Customer Service at [service@astm.org](mailto:service@astm.org).

11.2 *Repeatability*—The difference between successive test results obtained by the same operator with the same apparatus under constant operating conditions on identical test material, would in the long run, in the normal and correct operation of the test method, exceed the following values only in one case in twenty:

Copper rod color	– 1 unit
Steel rod color	– 1 unit
Total sludge	– 1.04 ( $X + 1$ )

where  $X$  denotes mean value.

11.3 *Reproducibility*—The difference between two single and independent results obtained by different operators working in different laboratories on identical test material would, in the long run, exceed the following values only in one case in twenty:

Copper rod color	– 4 units
Steel rod color	– 2 units
Total sludge	– 3.25 ( $X + 1$ )

where  $X$  denotes mean value.

11.4 *Bias*—Since there is no accepted reference material suitable for determining the bias for the procedure, bias has not been determined.

## 12. Keywords

12.1 Cincinnati Milacron; copper corrosion; Fives Cincinnati; heat test; hydraulic oils; oil sludging; steel corrosion; thermal stability

## ANNEX

### A1. ALUMINUM TEST FIXTURE

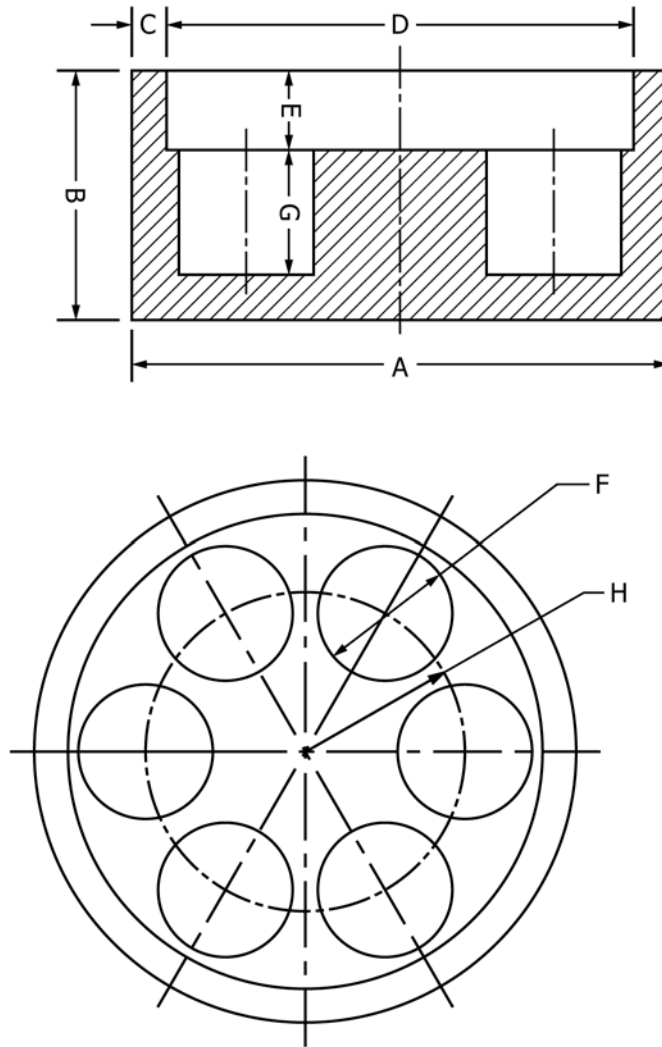

FIG. A1.1 Aluminum Test Fixture

	in.	mm
A – Overall diameter	12.00	304.8
B – Thickness	5.500	139.7
C – Edge thickness	0.7500	19.05
D – Recess diameter	10.50	266.7
E – Recess depth	1.750	44.45
F – Diameter of hole	3.000	76.20
G – Depth of hole	2.750	69.85
H – Distance from center to hole center	3.500	88.90

**SUMMARY OF CHANGES**

Subcommittee D02.N0 has identified the location of selected changes to this standard since the last issue (D2070 – 91 (2010)) that may impact the use of this standard. (Approved Dec. 15, 2016.)

(1) Updated source information throughout footnotes.

(2) Updated SI unit formatting.

*ASTM International takes no position respecting the validity of any patent rights asserted in connection with any item mentioned in this standard. Users of this standard are expressly advised that determination of the validity of any such patent rights, and the risk of infringement of such rights, are entirely their own responsibility.*

*This standard is subject to revision at any time by the responsible technical committee and must be reviewed every five years and if not revised, either reapproved or withdrawn. Your comments are invited either for revision of this standard or for additional standards and should be addressed to ASTM International Headquarters. Your comments will receive careful consideration at a meeting of the responsible technical committee, which you may attend. If you feel that your comments have not received a fair hearing you should make your views known to the ASTM Committee on Standards, at the address shown below.*

*This standard is copyrighted by ASTM International, 100 Barr Harbor Drive, PO Box C700, West Conshohocken, PA 19428-2959, United States. Individual reprints (single or multiple copies) of this standard may be obtained by contacting ASTM at the above address or at 610-832-9585 (phone), 610-832-9555 (fax), or [service@astm.org](mailto:service@astm.org) (e-mail); or through the ASTM website ([www.astm.org](http://www.astm.org)). Permission rights to photocopy the standard may also be secured from the Copyright Clearance Center, 222 Rosewood Drive, Danvers, MA 01923, Tel: (978) 646-2600; <http://www.copyright.com/>*