



# Standard Test Method for Propagation Tear Resistance of Plastic Film and Thin Sheeting by Pendulum Method<sup>1</sup>

This standard is issued under the fixed designation D1922; the number immediately following the designation indicates the year of original adoption or, in the case of revision, the year of last revision. A number in parentheses indicates the year of last reapproval. A superscript epsilon ( $\epsilon$ ) indicates an editorial change since the last revision or reapproval.

*This standard has been approved for use by agencies of the U.S. Department of Defense.*

## 1. Scope\*

1.1 This test method<sup>2</sup> covers the determination of the average force to propagate tearing through a specified length of plastic film or nonrigid sheeting after the tear has been started, using an Elmendorf-type tearing tester. Two specimens are cited, a rectangular type, and one with a constant radius testing length. The latter shall be the preferred or referee specimen.

1.2 Because of (1) difficulties in selecting uniformly identical specimens, (2) the varying degree of orientation in some plastic films, and (3) the difficulty found in testing highly extensible or highly oriented materials, or both, the reproducibility of the test results may be variable and, in some cases, not good or misleading. Provisions are made in the test method to address oblique directional tearing which may be found with some materials.

1.3 The values stated in SI units are to be regarded as standard. The values given in parentheses are for information only.

1.4 *This standard does not purport to address all of the safety concerns, if any, associated with its use. It is the responsibility of the user of this standard to establish appropriate safety and health practices and determine the applicability of regulatory limitations prior to use.* Specific precautionary statements are given in 13.1.

<sup>1</sup> This test method is under the jurisdiction of ASTM Committee D20 on Plastics and is the direct responsibility of Subcommittee D20.19 on Film, Sheeting, and Molded Products.

Current edition approved May 1, 2015. Published June 2015. Originally approved in 1961. Last previous edition approved in 2009 as D1922-09. DOI: 10.1520/D1922-15.

<sup>2</sup> This test method has been adapted from TAPPI Standard Method T 414M-49, Internal Tearing Resistance of Paper. In testing certain plastic films, problems of reproducibility and interpretation of results are encountered which require special treatment to make the test method of most value. This test method is revised here specifically for use with plastic film and thin sheeting. For more complete explanation of certain aspects of the equipment, its calibration and adjustment, refer to TAPPI Standard Method T 414M-49.

The following additional references may be of interest in connection with this test method:

Painter, E. V., Chu, C. C., and Morgan, H. M., "Testing Textiles on the Elmendorf Tear Tester," *Textile Research Journal*, Vol XX, No. 6, June 1950, pp. 410-417.

Elmendorf, A., "Strength Test for Paper," *Paper*, Vol 26, April 21, 1920, p. 302.

NOTE 1—Film has been arbitrarily defined as sheeting having nominal thickness not greater than 0.25 mm (0.010 in.).

NOTE 2—This standard is equivalent to ISO 6383-2.

## 2. Referenced Documents

### 2.1 ASTM Standards:<sup>3</sup>

D618 Practice for Conditioning Plastics for Testing

D689 Test Method for Internal Tearing Resistance of Paper (Withdrawn 2009)<sup>4</sup>

D1004 Test Method for Tear Resistance (Graves Tear) of Plastic Film and Sheeting

D4000 Classification System for Specifying Plastic Materials

D5947 Test Methods for Physical Dimensions of Solid Plastics Specimens

D6988 Guide for Determination of Thickness of Plastic Film Test Specimens

E691 Practice for Conducting an Interlaboratory Study to Determine the Precision of a Test Method

### 2.2 ISO Standard:

ISO 6383-2 Plastics—Film and Sheeting—Determination of Tear Resistance—Part 2 Elmendorf Method<sup>5</sup>

## 3. Summary of Test Method

3.1 The force in grams required to propagate tearing across a film or sheeting specimen is measured using a precisely calibrated pendulum device. Acting by gravity, the pendulum swings through an arc, tearing the specimen from a precut slit. The specimen is held on one side by the pendulum and on the other side by a stationary member. The loss in energy by the pendulum is indicated by a pointer. The scale indication is a function of the force required to tear the specimen.

<sup>3</sup> For referenced ASTM standards, visit the ASTM website, [www.astm.org](http://www.astm.org), or contact ASTM Customer Service at [service@astm.org](mailto:service@astm.org). For Annual Book of ASTM Standards volume information, refer to the standard's Document Summary page on the ASTM website.

<sup>4</sup> The last approved version of this historical standard is referenced on [www.astm.org](http://www.astm.org).

<sup>5</sup> Available from American National Standards Institute (ANSI), 25 W. 43rd St., 4th Floor, New York, NY 10036, <http://www.ansi.org>.

\*A Summary of Changes section appears at the end of this standard

#### 4. Significance and Use

4.1 This test method is of value in ranking relative tearing resistance of various plastic films and thin sheeting of comparable thickness. Experience has shown the test to have its best reliability on relatively less extensible films and sheeting. Variable elongation and oblique tearing effects on the more extensible films preclude its use as a precise production-control tool for these types of plastics. This test method should be used for specification acceptance testing only after it has been demonstrated that the data for the particular material are acceptably reproducible. This test method should be used for service evaluation only after its usefulness for the particular application has been demonstrated with a number of different films.

4.2 This test method has been widely used as one index of the tearing resistance of plastic film and thin sheeting used in packaging applications. While it is not always possible to correlate film tearing data with its other mechanical or toughness properties, the apparatus of this test method provides a controlled means for tearing specimens at straining rates approximating some of those found in actual packaging service.

4.3 Due to orientation during their manufacture, plastic films and sheeting frequently show marked anisotropy in their resistance to tearing. This is further complicated by the fact that some films elongate greatly during tearing, even at the relatively rapid rates of loading encountered in this test method. The degree of this elongation is dependent in turn on film orientation and the inherent mechanical properties of the polymer from which it is made. These factors make tear resistance of some films reproducible between sets of specimens to  $\pm 5\%$  of the mean value, while others potentially show no better reproducibility than  $\pm 50\%$ .

4.4 Data obtained by this test method may supplement that from Test Method **D1004**, wherein the specimen is strained at a rate of 50 mm (2 in.) per minute. However, specimen geometry and testing speed of the two test methods are dissimilar. The rate of tearing in this test method, while varying as a function of resistance to tear, is in the range from 7.6 to 46 m (300 to 1800 in./min).

4.5 There is not a direct, linear relationship between tearing force and specimen thickness. Data from this test method are expressed as tearing force in millinewtons (or grams-force, if desired), with specimen thickness also reported. But sets of data from specimens of dissimilar thickness are usually not comparable. Therefore, only data at the same thickness is compared.

4.6 For many materials, there may be a specification that requires the use of this test method, but with some procedural modifications that take precedence when adhering to the specification. Therefore, it is advisable to refer to that material specification before using this test method. Table 1 of Classification System **D4000** lists the ASTM materials standards that currently exist.

#### 5. Apparatus

5.1 *Pendulum Impulse-Type Testing Apparatus*,<sup>6</sup> consisting of the following:

5.1.1 *Stationary Clamp*.

5.1.2 *Movable Clamp*, carried on a pendulum, preferably formed by a sector of a wheel or circle, free to swing on a ball bearing or other substantially frictionless bearing.

5.1.3 *Stop Catch*, for holding the pendulum in a raised position and for releasing it instantaneously.

5.1.4 *Indicating Device*, for registering the maximum arc through which the pendulum swings when released. The pendulum shall carry a circumferential scale, graduated from 0 to 100 % of the machine capacity so as to read against the pointer the average force required to tear a specimen 43 mm (1.7 in.). The option to replace the pointer and scale by an electronic digital readout is available. Digital readouts are available which will give test results directly in millinewtons, directly in grams-force, or in percent of pendulum capacity. With the pendulum in its initial position ready for test, separate the two clamps by an interval of 2.54 mm (0.10 in.). So align them that the specimen clamped in them lies in a plane perpendicular to the plane of oscillation of the pendulum with the edges of the jaws gripping the specimen in a horizontal line, a perpendicular to which through the axis of suspension of the pendulum is  $102.7 \pm 0.05$  mm ( $4.044 \pm 0.002$  in.) in length and makes an angle of  $27.5^\circ$  with the plane of the film specimen. The clamping surface in each jaw shall be at least 25.4 mm (1 in.) in width and at least 12.7 mm (0.5 in.) in depth.

5.1.5 *Capacity*—Instruments of several capacities, 1960, 3920, 7840, 15 600, 31 360, 62 720 mN (200, 400, 800, 1600, 3200, 6400 gf), and perhaps others are available. These capacities are achieved by individual instruments, interchangeable pendulum sectors, or augmenting weights.

5.2 *Template, Die, or Shear-Type Cutter*<sup>6,7</sup>, for cutting specimens.

5.3 *Razor Blades*, single-edged, for cutting specimens where a template is used.

5.4 *Thickness-Measuring Device*—Micrometer, or other suitable thickness gauge for measuring the thickness of test specimens in accordance with Test Methods **D5947** or Guide **D6988** as appropriate.

#### 6. Test Specimens

6.1 Test specimens shall be cut using a die or template, as shown in **Fig. 1**, to form a constant-radius testing length. This shall be the preferred or referee specimen type since its geometry is intended to compensate to some degree for the problem of oblique tearing (**Note 3** and **Note 4**). Alternatively, specimens shall be cut to form a rectangle 76 mm (3 in.) or

<sup>6</sup> The sole source of supply of the apparatus known to the committee at this time is Thwing-Albert Instrument Co., Philadelphia, PA 19144. If you are aware of alternative suppliers, please provide this information to ASTM International Headquarters. Your comments will receive careful consideration at a meeting of the responsible technical committee,<sup>1</sup> which you may attend.

<sup>7</sup> The TA63 Sample Cutter, Catalog No. 98, available from the Thwing-Albert Instrument Co., Philadelphia, PA 19144, has been found satisfactory for cutting specimens.

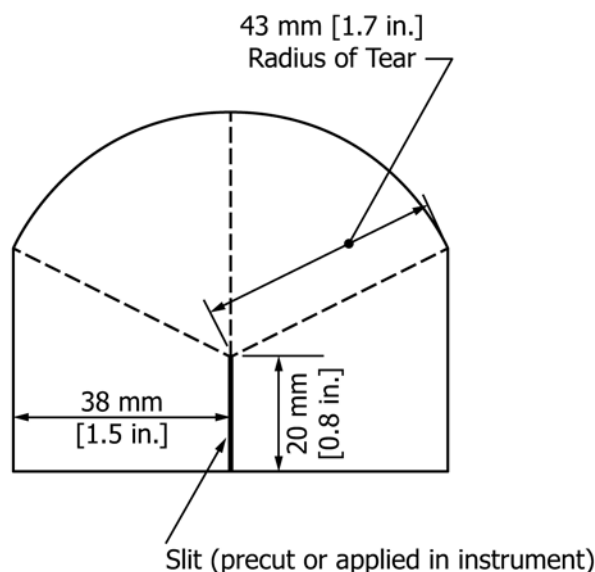

Tolerance =  $\pm 0.050$  mm (0.002 in.)

FIG. 1 Die or Template for Constant-Radius Test Specimen

more in width by 63 mm (2.5 in.) in length and plainly marked to denote intended direction of tear. The 63-mm specimen dimension shall be the direction of tear. Two sets of specimens shall be cut from each sample so that their sides are parallel to (1) the machine direction and (2) the transverse direction, respectively, of the material being tested. Enough specimens shall be cut in each direction to provide a minimum of ten tear strength determinations.

NOTE 3—Specimens having constant-radius testing lengths are designed to correct for oblique directional tearing encountered in certain anisotropic, elastomeric films, and nonrigid sheeting. For purposes of specimen selection, oblique tearing is defined as tearing in a curved or straight line that deviates more than 9.5 mm ( $\frac{3}{8}$  in.) from the vertical line of intended tear.

NOTE 4—Certain film and sheeting specimens showing oblique tearing may yield data of poor reproducibility because the axis of maximum orientation varies as much as  $30^\circ$  from the nominal machine direction. When this is suspected, the sample may be examined by crossed Polaroid plates to determine this direction of maximum orientation and the specimens cut along the axis of anisotropy for testing parallel and normal to it.

6.2 Where a metal template is used, the film or sheeting shall be placed on a hard surface. The template shall be held over it and the specimens cut out using a single-edged razor blade.

6.3 When the specimen is cut out, a slit 20 mm (0.8 in.) deep is to be made at the center of the edge perpendicular to the direction to be tested. This leaves exactly 43 mm (1.7 in.) of tearing length between the end of the slit and the opposite edge of the specimen. Alternatively, cut this slit into the specimen after it has been placed in the testing apparatus.

NOTE 5—The pendulum apparatus may be fitted with a sharp-loaded knife to make this slit in the specimen after it has been clamped in the apparatus. The action of the knife must be such as to make a clean slit exactly 20 mm (0.8 in.) into the specimen from the edge.

6.4 The test specimens shall conform to the dimensions in Fig. 1 for the constant-radius specimen or to the dimensions

noted in 6.1 for rectangular specimens and shall not vary more than 0.5 % from these dimensions.

## 7. Adjustment of Apparatus

### 7.1 Pendulum Friction:

7.1.1 *Older Instruments*—To check the pendulum swing for freedom from excess friction, level the apparatus and draw a pencil line on the base or stop mechanism 25.4 mm (1 in.) to the right of the edge of the sector stop. With the sector raised to its initial position and the pointer set against its stop, on releasing the sector and holding the stop down, the sector shall make at least 20 complete oscillations before the edge of the sector that engages with the stop no longer passes to the left of the pencil line. Otherwise, oil and adjust the bearing.

7.1.2 *Newer Instruments*—In recent years, a new type of frictionless bearing made of synthetic material has been used. This bearing will not necessarily allow the pendulum sector to make 20 complete oscillations as the older one did. This does not mean that there is excess friction in the pendulum swing. Consult the instructions supplied with the instrument for guidance before lubricating the bearings.

7.2 *Pointer Friction*—Check the pointer friction as follows: Set the pointer at zero reading on the scale before releasing the sector, and after release see that the pointer is not pushed more than three scale divisions beyond zero. A reading of more than three divisions indicates excessive pointer friction and the pointer needs to be removed, the bearing wiped clean, and a trace of oil or petroleum jelly applied. When the pointer friction has been reduced, finally adjust the pointer stop.

7.3 *Pointer Zero Reading*—To check the pointer for its zero point, level the apparatus so that, with the sector free, the line on the sector indicating the vertical point of suspension coincides with a corresponding point on the base of the apparatus, usually placed on the stop mechanism. After leveling, operate the apparatus several times with nothing in the jaws, the movable jaw being closed, to ascertain whether the pointer registers zero with no load. If zero is not registered, adjust the position of the pointer stop by means of the pointer stop thumb screw until a zero reading is obtained.

## 8. Verification of Scale

8.1 The scale is verified either by the procedure described in Test Method D689 and repeated here, or by the method which uses the Elmendorf check weights obtainable from the manufacturer. The method in Test Method D689 is relatively time-consuming and complicated. The check weight method is relatively simple.

### 8.2 Test Method D689 Procedure:

8.2.1 To verify the scale, first mark the center of gravity of the weight (including means of attaching) by a punched dot on the face of the weight. Then clamp a known weight in grams,  $W$ , to the radial edge of the sector beneath the jaws.

8.2.2 Raise and set the sector as for tearing a specimen and, by means of a suitable scale, measure the height in centimetres,  $h$ , of the center of gravity of the weight above the surface upon which the apparatus rests. Then release the sector, allow it to swing, and note the pointer reading. Without touching the pointer, raise the sector until the edge of the pointer just meets

with its stop, in which position again determine the height in centimetres,  $H$ , of the center of gravity of the weight above the surface.

8.2.3 The work done is  $W(H - h)$  gram-centimetres. The pointer reading noted above shall be the same as that calculated as follows:

$$W(H - h)/137.6$$

8.2.4 Five weights from 75 to 400 g form a suitable range for calibration of the apparatus, one or more being clamped on the edge of the sector in different positions. Calculate the work done in raising each and add together.

8.2.5 Make a record of deviations of the pointer from the calculated readings and make corresponding corrections in the test results at the proper points on the scale.

8.2.6 It is unnecessary to repeat the calibration of the instrument provided it is kept in adjustment and no parts become changed or worn.

### 8.3 Check Weight Method<sup>6,8</sup>:

8.3.1 Use a set of three check weights calibrated for scale values of 20, 50, and 80 % of the pendulum capacity. Sets of check weights of these values are available for each pendulum capacity. These weights need to be constructed so that each weight is inserted in the clamps by the procedure used for a test specimen.

8.3.2 With the pendulum in the raised position, open the clamp of the pendulum. Slide the tang of the weight into position, and fasten it securely into the clamp. The body of the weight must be beneath the clamp. Depress the pendulum stop, thus releasing the pendulum. Hold down the stop until after the tear is completed and catch the pendulum on the return swing. Read the indicating device to the nearest division.

8.3.3 Repeat this procedure with each of the check weights.

8.4 *Alternative Methods*—A variety of new techniques have been developed for scale verification of newer instruments including optical encoders utilizing a single check weight. For instruments that are capable of being verified using these techniques, the specific procedures recommended by the instrument supplier shall be followed.

## 9. Conditioning

9.1 *Conditioning*—Condition the test specimens at  $23 \pm 2^\circ\text{C}$  ( $73.4 \pm 3.6^\circ\text{F}$ ) and  $50 \pm 10\%$  relative humidity for not less than 40 h prior to test in accordance with Procedure A of Practice **D618** unless otherwise specified by agreement or the relevant ASTM material specification. In cases of disagreement, the tolerances shall be  $\pm 1^\circ\text{C}$  ( $\pm 1.8^\circ\text{F}$ ) and  $\pm 5\%$  relative humidity.

9.2 *Test Conditions*—Conduct the tests at  $23 \pm 2^\circ\text{C}$  ( $73.4 \pm 3.6^\circ\text{F}$ ) and  $50 \pm 10\%$  relative humidity unless otherwise specified by agreement or the relevant ASTM material specification. In cases of disagreement, the tolerances shall be  $\pm 1^\circ\text{C}$  ( $\pm 1.8^\circ\text{F}$ ) and  $\pm 5\%$  relative humidity.

## 10. Procedure

10.1 Test not less than ten specimens in each of the principal film or sheeting directions. Measure and record the thickness of each specimen as the average of three readings across its center in the direction in which it is to be torn. Read the thickness to a precision of 0.0025 mm (0.0001 in.) or better except for sheeting greater than 0.25-mm (10-mils) thickness, which is read to a precision of 0.025 mm (0.001 in.) or better.

10.2 One thickness determination per specimen or the average thickness determined by a continuous scanning instrument is acceptable if it is demonstrated that the overall thickness of the section of the roll from which the specimens were taken does not deviate  $> \pm 10\%$  from the average.

10.3 With the pendulum in its raised position, place the specimen midway in the clamps so that its upper edge is parallel to the top of the clamps and the initial slit (if it was made when the specimen was cut) is at the bottom of and between the clamps at right angles to their top.

10.4 Slit the firmly clamped specimen with the sharp spring-loaded knife if it has not been slit during cutting. Lay the upper testing portion of the specimen over in the direction of the pendulum pivot.

NOTE 6—The work done in tearing a specimen includes a certain amount of work to bend continuously the film or sheeting as it is torn, to provide for the rubbing of the torn edges of the specimen together, and to lift the specimen against the force of gravity. Consequently, it is necessary to specify certain empirical requirements for both the apparatus and the method to keep the additional work not used for tearing to approximately a definite quantity.

10.5 Release the sector stop and tear the specimen. As the sector completes its return swing, catch it with the thumb and forefinger of the left hand, being careful not to disturb the position of the pointer.

10.6 Record the pointer reading to the nearest 0.5 unit.

10.7 Examine the specimen. If the line of tear was more than approximately  $60^\circ$  from the vertical or, if rectangular specimens are tested, the specimen tore obliquely more than 9.5 mm ( $\frac{3}{8}$  in.) from the vertical line of intended tear, note and record this as an oblique (O) tear. Specimens that elongate along the line of tear to such an extent that the actual tearing length is more than the standard 43-mm (1.7-in.) dimension shall be noted in the same manner.

NOTE 7—The expected reproducibility of specimens failing in this manner is generally poorer than those that fail within the expected tear direction.

NOTE 8—If it is suspected that the axis of orientation differs significantly from the nominal machine direction, the test may be performed along and normal to the axis of maximum orientation (see **Note 4**).

NOTE 9—The maximum accuracy of the pendulum apparatus lies in the scale range from 20 to 60. When thin specimens are being tested, it may be advisable to test enough specimens sandwiched together to produce a scale reading between 20 and 60. However, certain specimens in the same sandwich may tear obliquely in opposite directions, which may lead to falsely high results. When this tearing behavior is encountered, single specimens must be tested, even though scale readings may be in the range below 20. If tearing loads are in excess of 60, the augmenting weight attachment may be used to double the capacity of the apparatus or a higher-capacity pendulum may be used. For thin film, it is recommended that single specimens and a lower-capacity tester be used rather than

<sup>8</sup> Elmendorf calibration check weights are available from the Thwing-Albert Instrument Co., Philadelphia, PA 19144. Use of these weights will permit direct calibration of the apparatus in a shorter time.



several specimens and a higher capacity machine. If the scale reading is below 10 on a 200-g pendulum, multiple plies may be used. The number of plies used should be the number required to bring the reading above 10.

## 11. Calculation

11.1 Calculate the average tearing force in millinewtons and, if desired, in grams-force as follows:

11.1.1 If the standard 1600-gf instrument with a 0 to 100 scale is used, calculate as follows:

$$\text{Average tearing force, mN} = \frac{16 \times 9.81 \times \text{average scale reading}}{n}$$

$$\text{Average tearing force, gf} = \frac{16 \times \text{average scale reading}}{n}$$

where:

$n = 1$ , or number of plies, if used. See [Note 7](#).

11.1.2 If an instrument of different grams-force capacity with a 0 to 100 scale is used, calculate as follows:

$$\text{Average tearing force, mN} = \frac{16 \times 9.81 \times \text{average scale reading} \times \text{gf} - \text{capacity}}{n \times 1600 \text{ gf}}$$

$$\text{Average tearing force, gf} = \frac{16 \times \text{average scale reading} \times \text{gf} - \text{capacity}}{n \times 1600 \text{ gf}}$$

where:

$n = 1$ , or number of plies, if used. See [Note 7](#).

11.1.3 If an instrument has an SI metric scale (for example, 0 to 1000 graduations), calculate as follows:

$$\text{Average tearing force, mN} = \frac{16 \times \text{average scale reading} \times \text{capacity, N}}{n \times 15.7 \text{ N}}$$

$$\text{Average tearing force, gf} = \frac{16 \times \text{average scale reading} \times \text{capacity, N}}{9.81 \times n \times 15.7 \text{ N}}$$

where:

$n = 1$ , or number of plies, if used. See [Note 7](#).

11.1.4 If an instrument has a direct-reading scale (for example, digital readout) in millinewtons, calculate as follows:

$$\text{Average tearing force, mN} = \frac{\text{average scale reading}}{n}$$

$$\text{Average tearing force, gf} = \frac{\text{average scale reading}}{9.81 \times n}$$

where:

$n = 1$ , or number of plies, if used. See [Note 7](#).

11.1.5 If an instrument has a direct-reading scale (for example, digital readout) in grams-force, calculate as follows:

$$\text{Average tearing force, mN} = \frac{\text{average scale reading} \times 9.81}{n}$$

$$\text{Average tearing force, gf} = \frac{\text{average scale reading}}{n}$$

where:

$n = 1$ , or number of plies, if used. See [Note 7](#).

**TABLE 1 Propagation Tear Resistance (Elmendorf Tear) Machine Direction**

| Material      | Values Expressed in Units of Grams-Force |         |         |       |       |
|---------------|--|---------|---------|-------|-------|
|               | Average                                  | $S_r^A$ | $S_R^B$ | $r^C$ | $R^D$ |
| Polystyrene   | 3.44                                     | 0.74    | 0.78    | 2.06  | 2.17  |
| HDPE No. 1    | 11.51                                    | 1.15    | 2.56    | 3.22  | 7.18  |
| HDPE No. 2    | 13.69                                    | 1.11    | 3.13    | 3.09  | 8.76  |
| Polypropylene | 15.46                                    | 1.50    | 1.93    | 4.19  | 5.41  |
| Polyester     | 53.45                                    | 1.34    | 3.60    | 3.74  | 10.09 |
| LDPE—LD 104   | 333.0                                    | 19.57   | 61.88   | 54.79 | 173.3 |
| LLDPE         | 377.4                                    | 12.35   | 52.28   | 34.58 | 146.4 |

<sup>A</sup>  $S_r$  = within-laboratory standard deviation for the material stated. It is obtained by pooling the standard deviations of the test results from each laboratory:

$$S_r = \left[ \frac{\sum (S_{r_i})^2 + (S_{r_2})^2 \dots + (S_{r_n})^2}{n} \right]^{1/2} \quad (1)$$

<sup>B</sup>  $S_R$  = between-laboratories standard deviation for the material stated. It is a pooling of the amounts by which the average of the test results for each laboratory deviate from the overall average for that material.

<sup>C</sup>  $r$  = within-laboratory repeatability limit =  $2.8 \times S_r$ .

<sup>D</sup>  $R$  = between-laboratories reproducibility limit =  $2.8 \times S_R$ .

A direct proportionality does not always exist between tearing force and specimen thickness. Therefore, this test method provides for reporting data in millinewtons, or, if desired, grams of force required to propagate tearing with specimen thickness reported separately.

11.2 Calculate the arithmetic mean,  $X$ , tearing resistance in each principal direction of the film or sheeting.

11.3 Calculate the standard deviation of the tearing resistance in each principal direction to two significant figures as follows:

$$s = \sqrt{(\sum X^2 - n\bar{X}^2)/(n-1)}$$

where:

$s$  = estimated standard deviation,

$X$  = value of a single observation,

$n$  = number of observations, and

$\bar{X}$  = arithmetic mean of the set of observations

11.4 If applicable, obtain the average, standard deviation, maximum, and minimum values of the tearing resistance from the digital readout device.

## 12. Report

12.1 Report the following information:

12.1.1 Complete identification of the sample tested including source, manufacturer's name and code number, method of fabrication, roll or lot number, and date received or made,

12.1.2 Type and direction of specimens tested: rectangular or constant radius, parallel or normal to the machine direction of the film. If tests were performed with reference to an axis of maximum orientation that did not coincide with the machine or transverse direction of the film, the report shall also include the location of this axis relative to the latter directions,

12.1.3 Number of specimens tested at one time, and the number tested in each principal direction of the film,

12.1.4 Average, maximum, and minimum values for specimen thickness and for machine and transverse tearing resistance (if data are obtained from specimens in both principal

**TABLE 2 Propagation Tear Resistance (Elmendorf Tear)  
Transverse Direction**

| Material      | Values Expressed in Units of Grams-Force |         |         |       |       |
|---------------|--|---------|---------|-------|-------|
|               | Average                                  | $S_r^A$ | $S_R^B$ | $r^C$ | $R^D$ |
| Polystyrene   | 3.03                                     | 0.89    | 1.00    | 2.48  | 2.80  |
| Polyester     | 55.96                                    | 1.36    | 4.44    | 3.81  | 11.59 |
| LDPE—LD 104   | 267.7                                    | 12.79   | 26.28   | 35.81 | 73.59 |
| HDPE No. 1    | 304.1                                    | 12.38   | 18.20   | 34.65 | 50.96 |
| HDPE No. 2    | 782.7                                    | 34.28   | 70.77   | 96.00 | 198.2 |
| LLDPE         | 804.4                                    | 40.18   | 58.27   | 112.5 | 163.2 |
| Polypropylene | 804.6                                    | 63.46   | 226.1   | 177.7 | 633.0 |

<sup>A</sup>  $S_r$  = within-laboratory standard deviation for the material stated. It is obtained by pooling the standard deviations of the test results from each laboratory:

$$S_r = \left[ \left[ \sum (S_i)^2 + (S_2)^2 \dots + (S_n)^2 \right] / n \right]^{1/2} \quad (2)$$

<sup>B</sup>  $S_R$  = between-laboratories standard deviation for the material stated. It is a pooling of the amounts by which the average of the test results for each laboratory deviate from the overall average for that material.

<sup>C</sup>  $r$  = within-laboratory repeatability limit =  $2.8 \times S_r$ .

<sup>D</sup>  $R$  = between-laboratories reproducibility limit =  $2.8 \times S_R$ .

directions), expressed in millinewtons, or grams-force, if desired to the nearest whole number,

12.1.4.1 If oblique tears were observed (see 10.7), include them in the average calculation and report the percentage of oblique tears as shown in the following:

Examples:

Average 50 g-f with 0 % oblique tears—50

Average 50 g-f with 30 % oblique tears—50(30)

Average 50 g-f with 100 % oblique tears—50(100)

12.1.5 Standard deviation from the average(s) of the tearing resistance in the machine and transverse directions, if both directions are tested, and

12.1.6 Capacity of the tester.

### 13. Precision and Bias<sup>9</sup>

13.1 Table 1 and Table 2 are based on a round robin conducted between 1986 and 1990 in accordance with Practice E691, involving seven materials tested by seven laboratories.

<sup>9</sup> Supporting data are available from ASTM Headquarters. Request RR:D20-1177.

For each material, all the samples were prepared at one source, and randomized sections of film were sent to each of the laboratories which prepared the test specimens and tested them. Each “test result” was the average of ten determinations. Each laboratory obtained two test results for each material.

NOTE 10—The following explanations of  $r$  and  $R$  (13.2 – 13.2.3) are only intended to present a meaningful way of considering the approximate precision of this test method. The data in Table 1 and Table 2 should not be rigorously applied to acceptance or rejection of material, as those data are specific to the round robin and may not be representative of other lots, conditions, materials, or laboratories. Users of this test method should apply the principles outlined in Practice E691 to generate data specific to their laboratory and materials, or between specific laboratories. The principles of 13.2 – 13.2.3 would then be valid for such data.

13.2 *Concept of  $r$  and  $R$  in Table 1 and Table 2*—If  $S_r$  and  $S_R$  have been calculated from a large enough body of data, and for test results that were the result of testing ten specimens for each test result then:

13.2.1 *Repeatability*—Two results obtained within one laboratory shall be judged not equivalent if they differ by more than the “ $r$ ” value for that material. “ $r$ ” is the interval representing the critical difference between two test results for the same material, obtained by the same operator using the same equipment on the same day in the same laboratory.

13.2.2 *Reproducibility*—Two test results obtained by different laboratories shall be judged not equivalent if they differ by more than the “ $R$ ” value for that material. “ $R$ ” is the interval representing the critical difference between two test results for the same material, obtained by different operators using different equipment in different laboratories.

13.2.3 Any judgment in accordance with 13.2.1 or 13.2.2 would have an approximate 95 % (0.95) probability of being correct.

13.3 There are no recognized standards by which to estimate of this method.

### 14. Keywords

14.1 Elmendorf; nonrigid sheeting; plastic film; tear; thin sheeting

## SUMMARY OF CHANGES

Committee D20 has identified the location of selected changes to this standard since the last issue (D1922 - 09) that may impact the use of this standard. (May 1, 2015)

(1) Edited permissive language throughout standard. Changes were made to: 4.2, 4.3, 4.5, 5.1.4, 5.1.5, 6.3, 7.1.1, 7.1.2, 7.2, 8.2.3, 8.3.1, 10.2, 10.7, 11.1.5, 11.4, and 12.1.2.

(2) Revised Precision and Bias section (13) to reflect the language in the most recent version of Guide D4968 for revising D20 standards. Created NOTE 10 as a result.

*ASTM International takes no position respecting the validity of any patent rights asserted in connection with any item mentioned in this standard. Users of this standard are expressly advised that determination of the validity of any such patent rights, and the risk of infringement of such rights, are entirely their own responsibility.*

*This standard is subject to revision at any time by the responsible technical committee and must be reviewed every five years and if not revised, either reapproved or withdrawn. Your comments are invited either for revision of this standard or for additional standards and should be addressed to ASTM International Headquarters. Your comments will receive careful consideration at a meeting of the responsible technical committee, which you may attend. If you feel that your comments have not received a fair hearing you should make your views known to the ASTM Committee on Standards, at the address shown below.*

*This standard is copyrighted by ASTM International, 100 Barr Harbor Drive, PO Box C700, West Conshohocken, PA 19428-2959, United States. Individual reprints (single or multiple copies) of this standard may be obtained by contacting ASTM at the above address or at 610-832-9585 (phone), 610-832-9555 (fax), or [service@astm.org](mailto:service@astm.org) (e-mail); or through the ASTM website ([www.astm.org](http://www.astm.org)). Permission rights to photocopy the standard may also be secured from the Copyright Clearance Center, 222 Rosewood Drive, Danvers, MA 01923, Tel: (978) 646-2600; <http://www.copyright.com/>*