



Standard Test Method for Resistance to Wetting of Garment-Type Leathers (Spray Test)¹

This standard is issued under the fixed designation D1913; the number immediately following the designation indicates the year of original adoption or, in the case of revision, the year of last revision. A number in parentheses indicates the year of last reapproval. A superscript epsilon (ϵ) indicates an editorial change since the last revision or reapproval.

1. Scope

1.1 This test method covers the qualitative evaluation of the surface repellency to water of garment-type leathers. This test method does not apply to wet blue.

1.2 The values stated in inch-pound units are to be regarded as standard. The values shown in parentheses are provided for information only.

1.3 *This standard does not purport to address all of the safety concerns, if any, associated with its use. It is the responsibility of the user of this standard to establish appropriate safety and health practices and determine the applicability of regulatory limitations prior to use.*

2. Summary of Test Method

2.1 Water is sprayed against the taut surface of the test specimen under controlled conditions, producing a pattern of wetting whose size depends on the relative repellency of the leather. Evaluation is accomplished by comparing the wetted pattern with pictures on a standard chart.

3. Significance and Use

3.1 The procedure is intended primarily to evaluate garment-type leathers. The test method is qualitative and measures the surface-water repellency or surface-water resistance only. It is not intended for use in determining resistance to water penetration. A visual means is given to evaluate the relative effects of materials showing water repellency, but no comparison is possible with conditions found in actual use.

¹ This test method is under the jurisdiction of ASTM Committee D31 on Leather and is the direct responsibility of Subcommittee D31.04 on Apparel. This test method was developed in cooperation with the American Leather Chemists Assn. (Standard Method E57 – 1963).

Current edition approved Sept. 1, 2015. Published October 2015. Originally approved in 1961. Last previous edition approved in 2010 as D1913 – 00 (2010). DOI: 10.1520/D1913-00R15.

4. Apparatus

4.1 *Spray Tester*—The spray tester (see Fig. 1 and Fig. 2)² shall consist of a standard spray nozzle (19 holes, drill No. 65, 0.035 in. (0.89 mm) in diameter) connected by means of $\frac{3}{8}$ -in. (9.5-mm) rubber tubing to the funnel tube of a 6-in. (152-mm) laboratory funnel; and a laboratory ring support which holds the funnel directly over the center of a 6-in. (152 mm) metal embroidery hoop mounted on a block of wood so that the plane of a specimen held on the hoop makes an angle of 45° with the horizontal. The distance of the nozzle to the center of the hoop-mounted specimen shall be 6.0 in. (152 mm).

4.2 *Rating Chart*.²

5. Test Specimen

5.1 The minimum size of the test specimen shall be 7 by 7 in. (178 by 178 mm). However, where nondestructive testing of skins is desired, the entire skin may be used and tested in any portion of its area.

5.2 Conditioning of the specimen prior to testing is not necessary.

6. Procedure

6.1 Fasten the specimen securely in the 6-in. (152-mm) metal hoop so that it presents a smooth, wrinkle-free surface. Place the hoop on the stand of the tester so that the surface to be evaluated is uppermost and in such a position that the center of the spray pattern coincides with the center of the hoop.

² The sole source of supply of the spray tester with standard spray nozzles, metal hoops, and copies of the rating chart known to the committee at this time is American Association of Textile Chemists and Colorists, P. O. Box 12215, Research Triangle Park, NC 27709; telephone: (919) 549-8141; fax: (919) 549-8933. If you are aware of alternative suppliers, please provide this information to ASTM Headquarters. Your comments will receive careful consideration at a meeting of the responsible technical committee,¹ which you may attend.

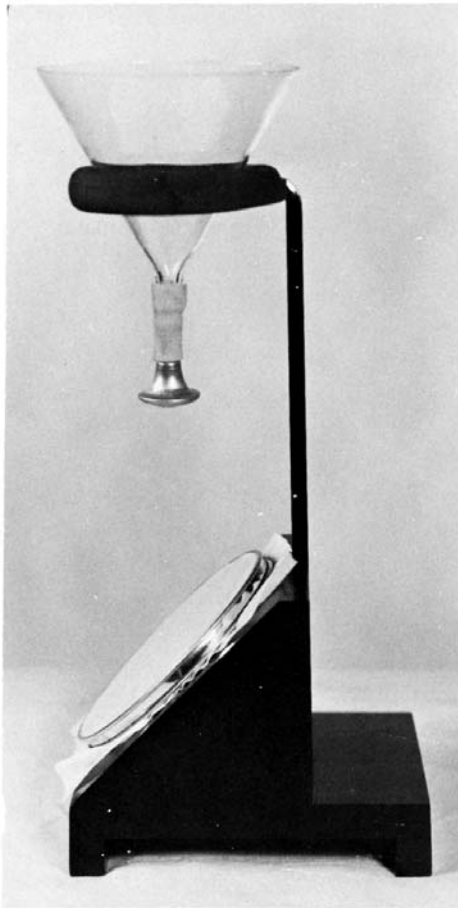

FIG. 1 Spray Tester

6.2 Pour 250 mL of water at $80 \pm 2^\circ\text{F}$ ($27 \pm 1^\circ\text{C}$) into the funnel of the tester and allow it to spray onto the test specimen. This will take approximately 25 to 30 s.

6.3 Upon completion of the spraying period, take the hoop by one edge, tap it smartly once against a solid object, then rotate it 180° and tap once more on the point previously held.

6.4 After tapping, compare the wet or spotted pattern with the rating chart, which is reproduced in Fig. 3. Assign the test specimen a rating corresponding to the nearest standard in the rating chart. Intermediate ratings should not be given.

7. Report

7.1 Report the rating determined in 6.4.

8. Precision and Bias

8.1 Interlaboratory correlation tests have suggested that positional effects within the skin are not large enough to cause differences in the ordinal scale values. Laboratory-to-laboratory differences greater than one level (10 units) in the ordinal scale are not probable.

9. Keywords

9.1 garment leather; spray test

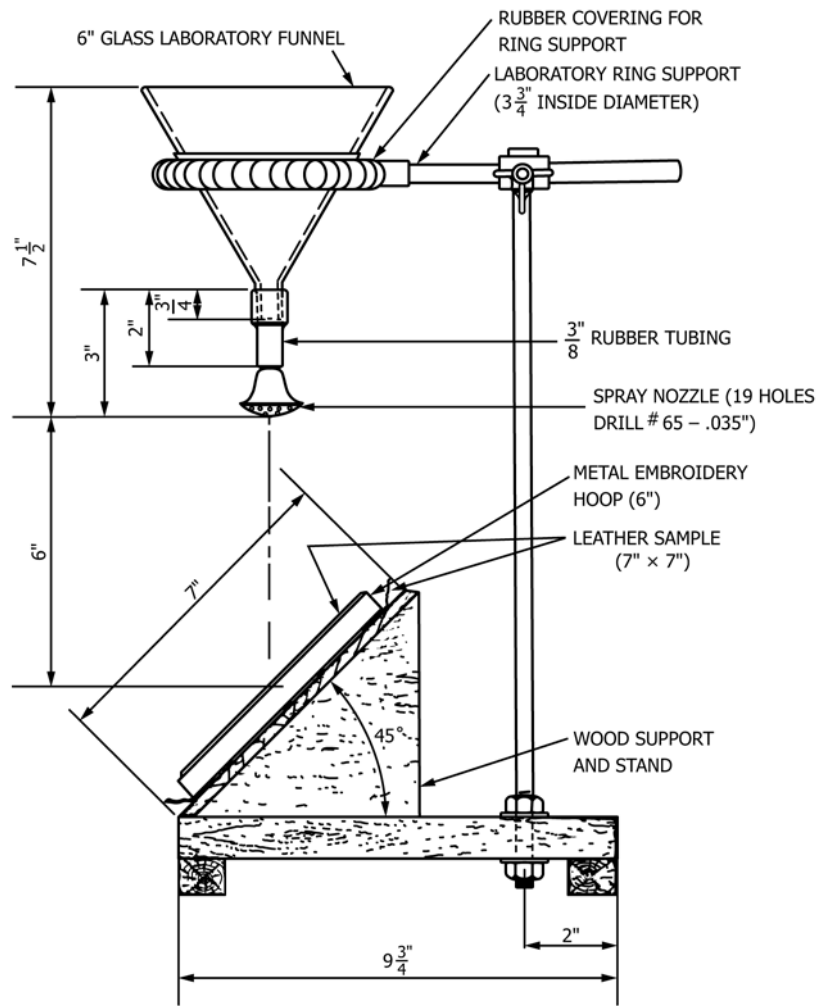

<i>in.</i>	3/8	3/4	2	3	3 3/4	6	7	7 1/2	9 3/4
<i>mm</i>	9.5	19	51	76	95	152	178	190	248

FIG. 2 Spray Tester Details

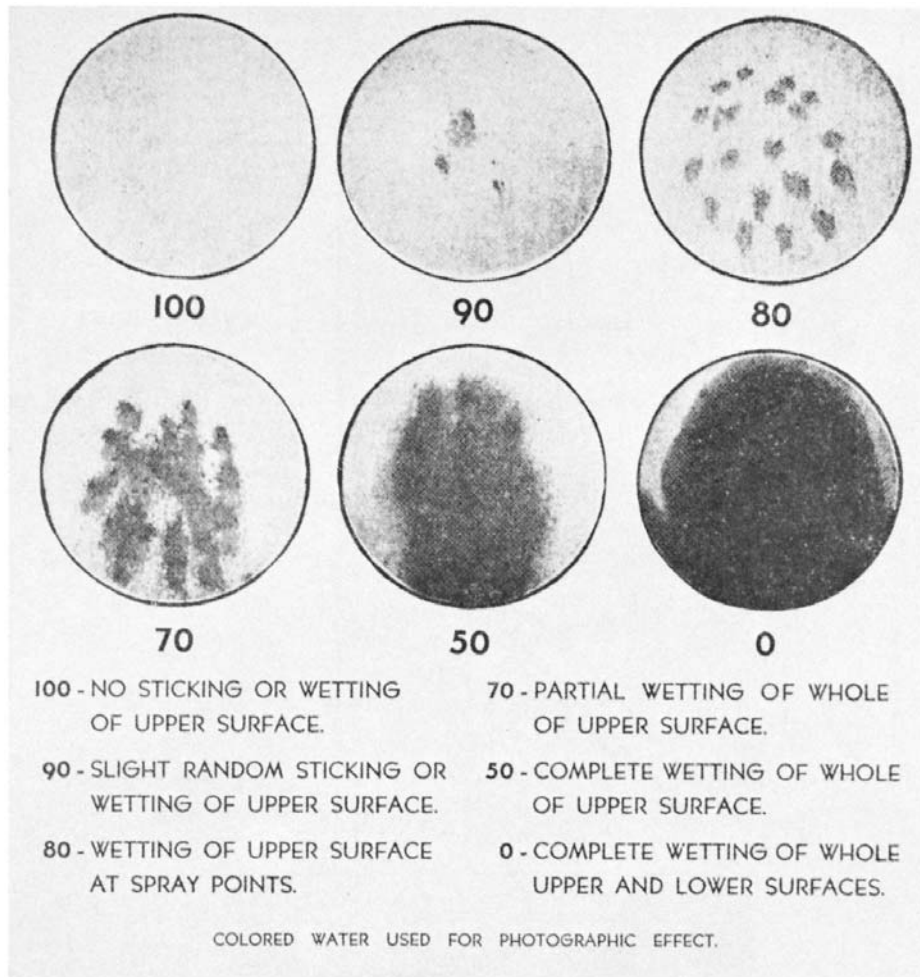

FIG. 3 Standard Spray Test Ratings

ASTM International takes no position respecting the validity of any patent rights asserted in connection with any item mentioned in this standard. Users of this standard are expressly advised that determination of the validity of any such patent rights, and the risk of infringement of such rights, are entirely their own responsibility.

This standard is subject to revision at any time by the responsible technical committee and must be reviewed every five years and if not revised, either reapproved or withdrawn. Your comments are invited either for revision of this standard or for additional standards and should be addressed to ASTM International Headquarters. Your comments will receive careful consideration at a meeting of the responsible technical committee, which you may attend. If you feel that your comments have not received a fair hearing you should make your views known to the ASTM Committee on Standards, at the address shown below.

This standard is copyrighted by ASTM International, 100 Barr Harbor Drive, PO Box C700, West Conshohocken, PA 19428-2959, United States. Individual reprints (single or multiple copies) of this standard may be obtained by contacting ASTM at the above address or at 610-832-9585 (phone), 610-832-9555 (fax), or service@astm.org (e-mail); or through the ASTM website (www.astm.org). Permission rights to photocopy the standard may also be secured from the Copyright Clearance Center, 222 Rosewood Drive, Danvers, MA 01923, Tel: (978) 646-2600; http://www.copyright.com/