



Standard Test Method for Roll Stability of Lubricating Grease¹

This standard is issued under the fixed designation D1831; the number immediately following the designation indicates the year of original adoption or, in the case of revision, the year of last revision. A number in parentheses indicates the year of last reapproval. A superscript epsilon (ϵ) indicates an editorial change since the last revision or reapproval.

This standard has been approved for use by agencies of the U.S. Department of Defense.

1. Scope

1.1 This test method covers determination of the changes in the consistency, as measured by cone penetration, of lubricating greases when worked in the roll stability test apparatus.

1.2 The values stated in SI units are to be regarded as standard. No other units of measurement are included in this standard.

1.2.1 *Exception*—The values stated in inch-pound units for the apparatus dimensions are to be regarded as standard; the SI conversions are provided for information only.

1.3 *This standard does not purport to address all of the safety concerns, if any, associated with its use. It is the responsibility of the user of this standard to establish appropriate safety and health practices and determine the applicability of regulatory limitations prior to use.*

2. Referenced Documents

2.1 *ASTM Standards*:²

[D217 Test Methods for Cone Penetration of Lubricating Grease](#)

[D1403 Test Methods for Cone Penetration of Lubricating Grease Using One-Quarter and One-Half Scale Cone Equipment](#)

[D4175 Terminology Relating to Petroleum, Petroleum Products, and Lubricants](#)

3. Terminology

3.1 *Definitions*:

3.1.1 *consistency, n—of lubricating grease*, the degree of resistance to movement under stress.

3.1.1.1 *Discussion*—The term consistency is used somewhat

¹ This test method is under the jurisdiction of ASTM Committee D02 on Petroleum Products and Lubricants and is the direct responsibility of Subcommittee D02.G0.02 on Consistency and Related Rheological Tests.

Current edition approved Jan. 1, 2011. Published January 2011. Originally approved in 1961. Last previous edition approved in 2006 as D1831-00(2006). DOI: 10.1520/D1831-11.

² For referenced ASTM standards, visit the ASTM website, www.astm.org, or contact ASTM Customer Service at service@astm.org. For *Annual Book of ASTM Standards* volume information, refer to the standard's Document Summary page on the ASTM website.

synonymously with penetration. Generally, consistency refers to the worked penetration of a grease. **D217**

3.1.2 *lubricant, n*—any material interposed between two surfaces that reduces the friction or wear between them. **D4175**

3.1.3 *lubricating grease, n*—a semi-fluid to solid product of a dispersion of a thickener in a liquid lubricant.

3.1.3.1 *Discussion*—The dispersion of the thickener forms a two-phase system and immobilizes the liquid lubricant by surface tension and other physical forces. Other ingredients imparting special properties are often included. **D217**

3.1.4 *penetration, n—of lubricating grease*, the depth that the standard cone, when released to fall under its own weight for 5 s, enters the sample. **D217**

3.1.5 *thickener, n—in lubricating grease*, a substance composed of finely divided particles dispersed in a liquid lubricant to form the product's structure.

3.1.5.1 *Discussion*—The thickener can be fibers (such as various metallic soaps) or plates or spheres (such as certain non-soap thickeners) which are insoluble or, at the most, only very slightly soluble in the liquid lubricant. The general requirements are that the solid particles be extremely small, uniformly dispersed, and capable of forming a relatively stable, gel-like structure with the liquid lubricant. **D217**

3.1.6 *worked penetration, n—of lubricating grease*, the penetration at 25°C (77°F), without delay, of a sample after 60 double strokes in a standard grease worker. **D217**

3.1.7 *working, n—of lubricating grease*, the subsection of a sample to the shearing action of the standard grease worker. **D217**

3.2 *Definitions of Terms Specific to This Standard*:

3.2.1 *roll stability, n—of lubricating grease*, the change in consistency of a sample after a specified amount of working in a test apparatus utilizing a weighted roller inside a rotating cylinder.

4. Summary of Test Method

4.1 The Test Methods [D1403](#) cone penetration of an approximately 50-g aliquot of lubricating grease is determined. The grease is then subjected to low shear at 20 to 35°C for 2 h \pm 5 min in a standard roll stability apparatus, before the cone penetration is again measured. The difference between the cone

penetration before working and the cone penetration after is used as a measure of the effect of low shear working on grease consistency.

5. Significance and Use

5.1 The roll stability test is widely used in specifications. Test results are significant insofar as they can show a directional change in consistency that could occur in service. No accurate correlation is established between the test results and shear stability in actual service.

6. Apparatus

6.1 *Roll Stability Test Apparatus*, capable of rotating a steel cylinder and 5 ± 0.05 kg roller weight at a rolling speed of 165 ± 15 rpm. One such example of a suitable apparatus is shown in Fig. 1.

6.2 *One-Quarter or One-Half Scale Cone and Shaft with Worker*, as described in Test Methods D1403.

7. Procedure

7.1 Determine the worked penetration in accordance with Test Methods D1403.

7.2 Transfer 50 ± 1 g of the unworked grease to the test cylinder. Distribute the grease uniformly on the inside wall of the cylinder with a spatula. Place the weighted roll in the cylinder and tighten the cap.

7.3 Mount the cylinder in position, start the machine, and record the time and room temperature which should be limited to 20 to 35°C. If the cylinder is enclosed within a cabinet, the temperature around the cylinder shall be maintained at 20 to 35°C.

7.4 After rolling for 2 h ± 5 min, remove the grease from the cylinder promptly and proceed with the requirements of worked penetration in Test Methods D1403. Record the worked penetration. After transferring the grease to the worker, clean the roll stability test apparatus by wiping with clean cloth or tissue.

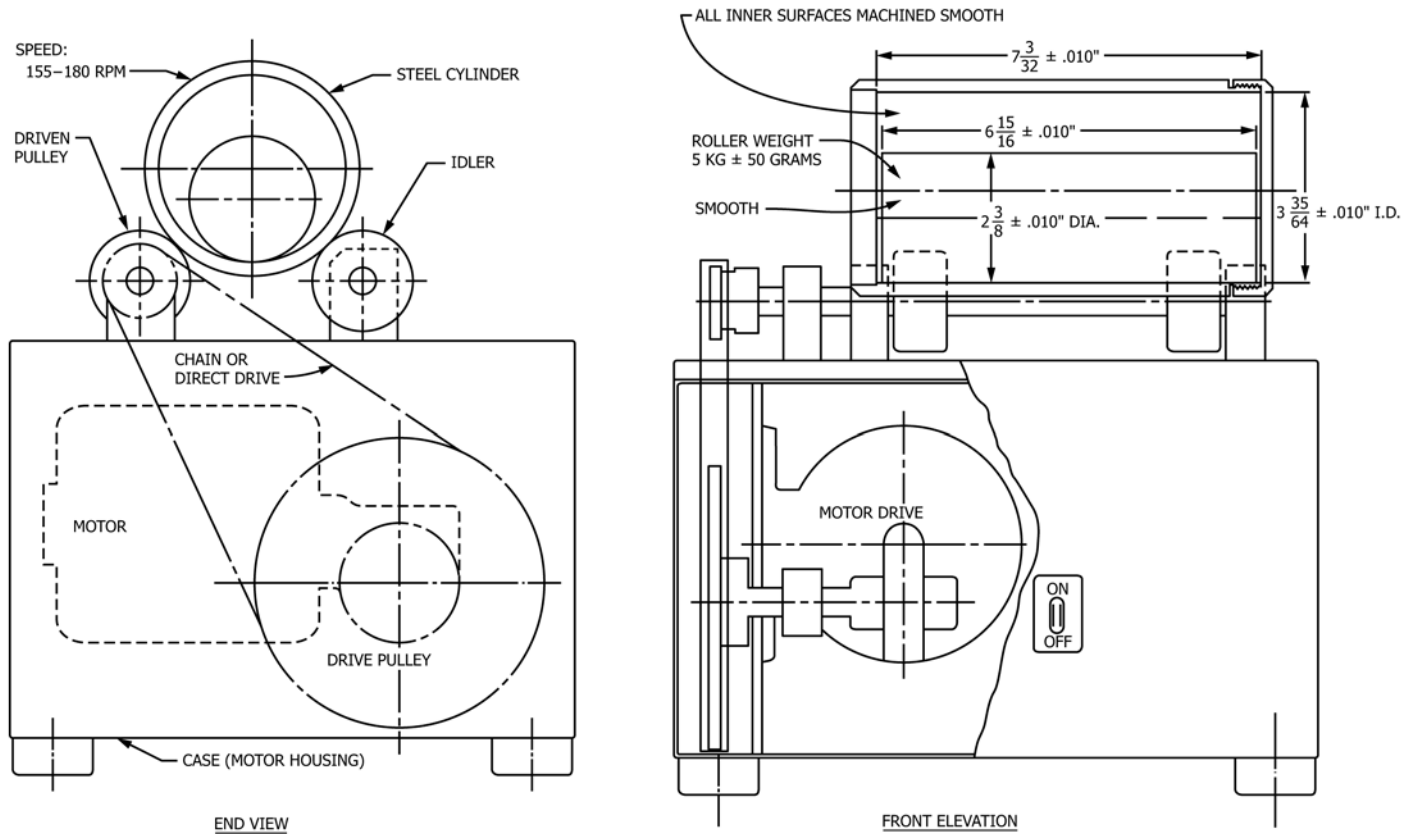

NOTE 1—SI Equivalents:

Inches	Millimetres
0.010	0.25
2 3/8	60.33
3 35/64	90.09
6 15/16	176.21
7 3/32	180.18

FIG. 1 Roll Stability Tester

7.5 Convert the fractional scale penetration values determined by Test Methods **D1403** (before and after rolling) into the equivalent full scale cone penetration values using the appropriate equations described in Test Methods **D1403**.

8. Calculation

8.1 Calculate the change in consistency of the sample as follows:

$$\text{Penetration change} = P_2 - P_1 \quad (1)$$

where:

P_2 = final full-scale penetration reading, and
 P_1 = initial full-scale penetration reading.

NOTE 1—Penetration readings are measured in tenths of a millimetre. A negative penetration change indicates hardening of a grease while a positive penetration change indicates softening.

9. Report

9.1 The value calculated in 8.1 is reported as the change in consistency.

10. Precision and Bias³

10.1 The precision of this test method is not known to have been obtained in accordance with currently accepted guidelines (for example in Committee D02 research report RR:D02-1007, “Manual on Determining Precision Data for ASTM Methods on Petroleum Products and Lubricants”).

10.2 The precision of the test method (Note 2) as determined by statistical examination of interlaboratory results is as follows:

³ No research report is on file because this test method was developed before research report guidelines were instituted and the round-robin data are no longer available.

NOTE 2—The criteria for repeatability and reproducibility are based on the spread in the numbers after conversion to the full-scale units described in Test Methods **D1403**. Precision of this test method was established using the one-quarter scale equipment, but based on the precision values in Test Methods **D1403**, the precision of this test should be at least as good or better using the one-half scale equipment.

10.2.1 *Repeatability*—The difference between two test results, obtained by the same operator with the same apparatus under constant operating conditions on identical test material, would in the long run, in the normal and correct operation of the test method, exceed the following values only in one case in twenty:

Range of Sample	Repeatability
NLGI ⁴ Consistency Nos. 1 and 2	11 penetration units—tenths of a millimetre

10.2.2 *Reproducibility*—The difference between two single and independent results obtained by different operators working in different laboratories on identical test material would, in the long run, in the normal and correct operation of the test method, exceed the following values only in one case in twenty:

Range of Sample	Reproducibility
NLGI ⁴ Consistency Nos. 1 and 2	45 penetration units—tenths of a millimetre

10.3 *Bias*—The procedure in Test Method D1831 has no bias because the value of the change in penetration can be defined only in terms of a test method.

11. Keywords

11.1 cone penetration; consistency; lubricating grease; penetration; roll stability; shear stability

⁴ NLGI International Headquarters, 4635 Wyandotte St., Suite 202, Kansas City, MO 64112.

ASTM International takes no position respecting the validity of any patent rights asserted in connection with any item mentioned in this standard. Users of this standard are expressly advised that determination of the validity of any such patent rights, and the risk of infringement of such rights, are entirely their own responsibility.

This standard is subject to revision at any time by the responsible technical committee and must be reviewed every five years and if not revised, either reapproved or withdrawn. Your comments are invited either for revision of this standard or for additional standards and should be addressed to ASTM International Headquarters. Your comments will receive careful consideration at a meeting of the responsible technical committee, which you may attend. If you feel that your comments have not received a fair hearing you should make your views known to the ASTM Committee on Standards, at the address shown below.

This standard is copyrighted by ASTM International, 100 Barr Harbor Drive, PO Box C700, West Conshohocken, PA 19428-2959, United States. Individual reprints (single or multiple copies) of this standard may be obtained by contacting ASTM at the above address or at 610-832-9585 (phone), 610-832-9555 (fax), or service@astm.org (e-mail); or through the ASTM website (www.astm.org). Permission rights to photocopy the standard may also be secured from the Copyright Clearance Center, 222 Rosewood Drive, Danvers, MA 01923, Tel: (978) 646-2600; http://www.copyright.com/