



Standard Test Method for Dielectric Breakdown Voltage of Insulating Liquids Using VDE Electrodes¹

This standard is issued under the fixed designation D1816; the number immediately following the designation indicates the year of original adoption or, in the case of revision, the year of last revision. A number in parentheses indicates the year of last reapproval. A superscript epsilon (ϵ) indicates an editorial change since the last revision or reapproval.

1. Scope*

1.1 This test method covers the determination of the dielectric breakdown voltage of insulating liquids (oils of petroleum origin, silicone fluids, high fire-point mineral electrical insulating oils, synthetic ester fluids and natural ester fluids). This test method is applicable to insulating liquids commonly used in cables, transformers, oil circuit breakers, and similar apparatus as an insulating and cooling medium. Refer to Terminology [D2864](#) for definitions used in this test method.

1.2 This test method is sensitive to the deleterious effects of moisture in solution especially when cellulosic fibers are present in the liquid. It has been found to be especially useful in diagnostic and laboratory investigations of the dielectric breakdown strength of insulating liquid in insulating systems.²

1.3 This test method is used to judge if the VDE electrode breakdown voltage requirements are met for insulating liquids. This test method should be used as recommended by professional organization standards such as IEEE C57.106.

1.4 This test method may be used to obtain the dielectric breakdown of silicone fluid as specified in Test Method [D2225](#) and Specification [D4652](#), provided that the discharge energy into the sample is less than 20 mJ (milli joule) per breakdown for five consecutive breakdowns.

1.5 Both the metric and the alternative inch-pound units are acceptable.

1.6 *This standard does not purport to address all of the safety concerns, if any, associated with its use. It is the responsibility of the user of this standard to establish appropriate safety and health practices and determine the applicability of regulatory limitations prior to use.*

¹ This test method is under the jurisdiction of ASTM Committee [D27](#) on Electrical Insulating Liquids and Gases and is the direct responsibility of Subcommittee [D27.05](#) on Electrical Test.

Current edition approved June 15, 2012. Published July 2012. Originally approved in 1960 as D1816 – 60 T. Last previous edition approved in 2004 as D1816 – 04. DOI: 10.1520/D1816-12.

² Supporting data is available from ASTM Headquarters. Request RR:D27-1006.

2. Referenced Documents

2.1 ASTM Standards:³

[D235](#) Specification for Mineral Spirits (Petroleum Spirits) (Hydrocarbon Dry Cleaning Solvent)

[D923](#) Practices for Sampling Electrical Insulating Liquids
[D2225](#) Test Methods for Silicone Fluids Used for Electrical Insulation

[D2864](#) Terminology Relating to Electrical Insulating Liquids and Gases

[D3487](#) Specification for Mineral Insulating Oil Used in Electrical Apparatus

[D4652](#) Specification for Silicone Fluid Used for Electrical Insulation

[D6871](#) Specification for Natural (Vegetable Oil) Ester Fluids Used in Electrical Apparatus

2.2 IEEE Standard:

[Standard 4](#) IEEE Standard Techniques for High Voltage Testing⁴

[C57.106](#) Guide for Acceptance and Maintenance of Insulating Oil in Equipment⁴

3. Significance and Use

3.1 The dielectric breakdown voltage of an insulating liquid is of importance as a measure of the liquid's ability to withstand electric stress without failure. The dielectric breakdown voltage serves to indicate the presence of contaminating agents such as water, dirt, cellulosic fibers, or conducting particles in the liquid, one or more of which may be present in significant concentrations when low breakdown voltages are obtained. However, a high dielectric breakdown voltage does not necessarily indicate the absence of all contaminants; it may merely indicate that the concentrations of contaminants that are present in the liquid between the electrodes are not large enough to deleteriously affect the average breakdown voltage of the liquid when tested by this test method (see [Appendix X1](#).)

³ For referenced ASTM standards, visit the ASTM website, www.astm.org, or contact ASTM Customer Service at service@astm.org. For Annual Book of ASTM Standards volume information, refer to the standard's Document Summary page on the ASTM website.

⁴ Available from the Institute of Electrical and Electronic Engineers, Inc., PO Box 1331, Piscataway, NJ 08855.

*A Summary of Changes section appears at the end of this standard

3.2 This test method is used in laboratory or field tests. For field breakdown results to be comparable to laboratory results, all criteria including room temperature (20 to 30°C) must be met.

4. Electrical Apparatus

4.1 In addition to this section, use IEEE Standard 4 to determine other requirements necessary for conducting test measurements, and maintaining error limits using alternating voltages. Procedures to ensure accuracy should follow the requirements of IEEE Standard 4. Calibration(s) shall be traceable to national standards and calibration should be verified annually or more often to ensure accuracy requirements. IEEE Standard 4 is required during the manufacturing of the test apparatus and utilized during calibration of the equipment.

4.1.1 *Test Voltage*—The test voltage shall be an alternating voltage having a frequency in the range from 45 to 65 Hz, normally referred to as power-frequency voltage. The voltage wave shape should approximate a sinusoid with both half cycles closely alike, and it should have a ratio of peak-to-rms values equal to the square root of 2 within ±5 %.

4.1.2 *Generation of the Test Voltage*— The test voltage is generally supplied by a transformer or resonant circuit. The voltage in the test circuit should be stable enough to be unaffected by varying current flowing in the capacitive and resistive paths of the test circuit. Non-disruptive discharges in the test circuit should not reduce the test voltage to such an extent, and for such a time, that the disruptive discharge (breakdown) voltage of the test specimen is significantly affected. In the case of a transformer, the short-circuit current delivered by the transformer should be sufficient to maintain the test voltage within 3 % during transient current pulses or discharges, and a short circuit current of 0.1 A may suffice.

4.1.3 *Disruptive Voltage Measurement*— Design the measurement circuit so the voltage recorded at the breakdown is the maximum voltage across the test specimen immediately prior to the disruptive breakdown, with an error no greater than 3 %.

4.2 *Circuit-Interrupting Equipment*— Design the circuit used to interrupt the disruptive discharge through the specimen to operate when the voltage across the specimen has collapsed to less than 100 V. It is recommended that the circuit design limit the disruptive current duration and magnitude to low values that will minimize damage to the electrodes and limit formation of non-soluble materials resulting from the breakdown, but consistent with the requirements of 4.1.2, but in no case should the short-circuit current exceed 1 mA/kV of applied voltage.

4.3 *Voltage Control Equipment*—Use a rate of voltage rise of 0.5 kV/s. The tolerance of the rate of rise should be 5 % for any new equipment manufactured after the year 2000. Automatic equipment should be used to control the voltage rate of rise because of the difficulty of maintaining a uniform voltage rise manually. The equipment should produce a straight-line voltage-time curve over the operating range of the equipment. Calibrate and label automatic controls in terms of rate-of-rise.

4.4 *Measuring Systems*—The voltage shall be measured by a method that fulfills the requirements of IEEE Standard No. 4, giving rms values.

4.5 Connect the electrode such that the voltage measured from each electrode with respect to ground during the test is equal within 5 %.

4.6 *Accuracy*—The combined accuracy of the voltmeter and voltage divider circuit shall be such that measurement error does not exceed 3 % at the rate-of-voltage rise specified in 4.3. For equipment manufactured prior to 1995 the maximum allowable error is 5 %.

5. Electrodes

5.1 The electrodes shall be polished brass spherically-capped electrodes of the VDE (Verband Deutscher Elektrotechniker, Specification 0370) type having the dimensions shown in Fig. 1 ±1 %, mounted with axes horizontal and coincident within ±1 mm.

6. Test Cell

6.1 The test cell shall be designed to permit easy removal of the electrodes for cleaning and polishing, verification that the shape is within the specified tolerance, and to permit easy adjustment of the gap spacing. The vector sum of the resistive and capacitive current of the cup, when filled with oil meeting the requirements of Specification D3487, shall be less than 200 µA at 20 kV, at power frequency. Mount the electrodes rigidly from opposite sides with the spacing axially centered within ±1 mm. Clearance from the electrodes to all sides, bottom, cover or baffle, and any part of the stirring device is at least 12.7 mm (½ in.). Provide the test cell with a motor-driven two-bladed impeller and drive shaft, constructed of a material having high dielectric strength. The two-bladed impeller is 35 mm (1⅜ in.) ±5 % between the blade extremities, having a

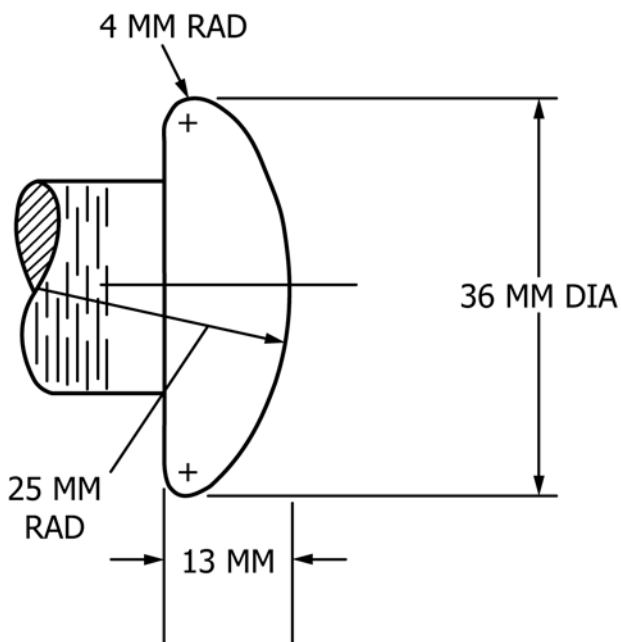

FIG. 1 VDE Electrode

pitch of 40 mm (1.57 in.) $\pm 5\%$ (blade angle of twenty degrees (20°) $\pm 5\%$), operating at a speed between 200 and 300 rpm. The impeller, located below the lower edge of the electrodes, rotates in such a direction that the resulting liquid flow is directed downward against the bottom of the test cell. Construct the test cell of a material of high dielectric strength, that is not soluble in or attacked by any of the cleaning or test liquids used, and is nonabsorbent to moisture and the cleaning and test liquids. So that the breakdown may be observed, transparent materials are desirable, but not essential. In order to preclude stirring air with the sample, provide the cell with a cover or baffle that will effectively prevent air from contacting the circulating liquid.

7. Adjustment and Care of Electrodes and Test Cell

7.1 Electrode Spacing—With the electrodes held firmly in place, check the electrodes with a standard round gage for 2 ± 0.03 -mm (0.079-in.) spacing. If a dielectric breakdown does not occur during any of the consecutive breakdown tests using the 2 mm spacing or the sample is not adequate for the 2 mm spacing test cell a 1 ± 0.03 -mm (0.039-in.) spacing should be used to determine the breakdown voltage and the spacing reported. Flat “go” and “no-go” gages may be substituted having thicknesses of the specified value ± 0.03 mm for electrode spacing of 1 or 2 mm. If it is necessary to readjust the electrodes, set the electrodes firmly in place and check the spacing. For referee tests or tests that will be used for close comparisons, the laboratories shall agree in advance on the spacing for the tests and ensure that all other requirements of this test method are met. The spacing agreed upon shall be measured with the gage that corresponds exactly to the selected spacing within tolerance stated above for the gage.

7.2 Cleaning—Wipe the electrodes and cell clean with dry, lint-free tissue paper, or a clean dry chamois. It is important to avoid touching the electrodes or the cleaned gage with the fingers or with portions of the tissue paper or chamois that have been in contact with the hands. After adjustment of the spacing, rinse the cell with a dry hydrocarbon solvent, such as kerosine or solvents of Specification **D235**. Do not use a low boiling point solvent, as its rapid evaporation may cool the cell, causing moisture condensation. If this occurs, before using, warm the cell to evaporate the moisture. Avoid touching the electrodes or the inside of the cell after cleaning. After thorough cleaning, flush the cell with new insulating liquid of the type to be tested that is filtered through a 5-micron filter or smaller and containing less than 25 ppm moisture. Conduct a voltage breakdown test on a specimen of this insulating liquid in the manner specified in this test method. If the breakdown voltage is in the expected range for this conditioned insulating liquid, the cell is considered properly prepared for testing other samples. A lower than anticipated value is considered as evidence of cell contamination; then repeat the cleaning and the breakdown test with clean dry insulating liquid.

7.3 Daily Use—At the beginning of each day’s testing, the electrodes shall be examined for pitting and carbon accumulation, and the spacing checked. If the test of any sample is below the breakdown value being used by the operator as a minimum satisfactory value, drain the cell and

flush the cell with new insulating liquid of the type to be tested that is filtered through a 5-micron filter and containing less than 25 ppm moisture before testing the next specimen. When not in use, keep the cell filled with oil that meets the requirements of Specification **D3487** of the type normally tested. Alternatively, the cell may be stored empty in a dust-free cabinet. At the beginning of each days testing, clean according to **7.2**.

7.4 Polishing of Electrodes—When electrodes show slight etching, scratching, pitting, or carbon accumulation, they should be removed from the test cup and polished by buffing with jeweler’s rouge using a soft cloth or soft buffing wheel. The residue from the buffing should be removed by repeated wiping with lint-free tissue paper saturated with a suitable solvent, followed by solvent rinsing or ultrasonic cleaning. After careful inspection, any electrodes from which pitting cannot be removed by light buffing should be discarded, as more refinishing would destroy the electrode contour and dimensions shown in **Fig. 1**. Reinstall the electrodes in the test cup and adjust spacing and clean in accordance with **7.1** and **7.2**.

8. Sampling

8.1 Obtain a sample of the insulating liquid to be tested using appropriate ASTM sampling apparatus. Insulating liquid sampling procedures are detailed in Practice **D923**. Particular reference should be made to the general precaution statement of this test method. The sample shall be taken in a dry, clean, non-permeable bottle. Tightly seal and shield from light until ready to be tested. Plastic bottles are permeable and moisture content of the sample may change resulting in a measurable difference when compared to samples collected in non-permeable containers. Prior to starting the test, the sample shall be inspected for the presence of moisture, sludge, metallic particles, or other foreign matter. If the sample shows evidence of free water, the dielectric breakdown test should be waived, and the sample reported as unsatisfactory.

9. Test Procedure

9.1 Allow the sample and the test cup to equilibrate to ambient temperature. Laboratory and referee tests shall be conducted at room temperature (20 to 30°C).

9.2 To ensure a homogenous sample, gently invert and swirl the sample container several times. Rapid agitation is undesirable, since an excessive amount of air may be introduced into the liquid. Within 1 min after agitation, use a small portion of the sample to rinse the test cell. Drain the rinse. Within 30 s of the rinse, fill the cell slowly with the remaining portion of the sample. The cell is full when closing the cover or baffle allows no air to be in contact with the insulating liquid.

9.3 Wait at least 3 min but no more than 5 min between filling the cup and application of voltage for the first breakdown. For high fire-point electrical insulating oils, natural esters and synthetic esters, the hold time before the initial application of voltage shall be at least 30 min. Apply the voltage increasing from zero at the rate of $0.5 \text{ kV/s} \pm 5\%$ until breakdown occurs as indicated by operation of the circuit-interrupting equipment; record the highest rms voltage value

that occurred immediately prior to each breakdown. Occasional momentary discharges may occur which do not result in operation of the interrupting equipment; these shall be disregarded until the voltage across the specimen collapses to less than 100 V. Conduct four additional breakdowns waiting at least 60 s but no more than 90 s before applications of voltage for successive breakdowns. (During the intervals before voltage application, between breakdowns, and at the time voltage is being applied, the propeller shall be circulating the insulating liquid.)

9.4 Calculate the mean of the five breakdowns as follows:

$$\bar{X} = \frac{1}{5} \sum_{i=1}^5 X_i$$

where:

\bar{X} = mean of the five individual values,

X_i = *i*th breakdown voltage.

9.5 Using the breakdown voltage values determined in 9.3, determine that the range of the five (5) breakdown voltages does not exceed the values indicated as follows:

$$\text{Range} = X_{\text{Highest}} - X_{\text{Lowest}}$$

where:

X_{Highest} = the highest breakdown voltage of the five readings, and

X_{Lowest} = the lowest breakdown of the five readings.

1 mm gap setting	Range must be less than 120 % of the mean of the five (5) breakdown voltages
2 mm gap setting	Range must be less than 92 % of the mean of the five (5) breakdown voltages

If this range is exceeded and there is sufficient volume of test specimen, repeat the analysis on a new cup filling. If an insufficient volume of test specimen is available, the test result can be reported with an additional comment that the range of the breakdowns exceeds the allowable range.

9.6 When it is desired merely to determine if the dielectric strength is above or below a specified level, five breakdowns are required, provided the five values are all above or all below this level. Otherwise, follow the procedure described in 9.3 – 9.5

10. Report

10.1 Include in the report the following:

10.1.1 The test method used,

10.1.2 The volts (rms value) at each breakdown, and the mean of all breakdowns reported to two significant digits,

10.1.3 The approximate temperature of the insulating liquid at the time of the test, and

10.1.4 The electrode spacing.

11. Precision and Bias⁵

11.1 *Single-Operator Precision*—The single operator percent coefficient of variance of a single test result comprised of 5 breakdowns has been found for the 1 mm gap to be 14 % and for the 2 mm gap 11 %. Therefore, results of two properly conducted tests by the same operator on the same sample should not differ by more than 40 % and 30 % respectively. The maximum allowable range for the series of 5 breakdowns should not exceed 120 % for the 1 mm gap and 92 % for the 2 mm gap.

11.2 *Multilaboratory Precision*—The multilaboratory percent coefficient of variance has been found for the 1 mm gap to be 17 % and for the 2 mm gap 14 %. Therefore, two separate test results conducted by separate laboratories on the same sample of insulating liquid should not differ by more than 47 % of the mean of the two tests if the 1 mm gap was used or differs by more than 40 % of the mean of the two tests if the 2 mm gap was used. The precision statement for the 1 mm gap is temporary, because sufficient laboratories were not available and testing is planned to replace the precision statement before 2009.

11.3 *Bias*—No statement can be made about the bias of this test method because a standard reference material is not available.

12. Keywords

12.1 breakdown voltage; dielectric strength; insulating liquids; insulating oils; test cell; VDE electrodes

⁵ Supporting data is available from ASTM International Headquarters. Request RR:D27-1014.

APPENDIX

(Nonmandatory Information)

X1. FACTORS THAT AFFECT THE DIELECTRIC BREAKDOWN VOLTAGE OF INSULATING LIQUIDS AT COMMERCIAL POWER FREQUENCIES

X1.1 The dielectric breakdown voltage of an insulating liquid at commercial power frequencies is also affected by:

X1.1.1 The degree of uniformity of the electric field,

X1.1.2 The area of the electrodes,

X1.1.3 Volume of the insulating liquid under maximum stress,

X1.1.4 Insulation on the electrodes,

X1.1.5 Water content of the insulating liquid,

X1.1.6 Size and number of particles in the insulating liquid,

X1.1.7 Length of time for which the insulating liquid is under stress,

X1.1.8 The temperature of the insulating liquid as it affects the relative saturation level of moisture in solution,

X1.1.9 Gassing tendencies of the insulating liquid under the influence of electric stress,

X1.1.10 Concentration of dissolved gases if saturation levels are exceeded as a result of a sudden cooling or decrease in pressure, which may cause the formation of gas bubbles,

X1.1.11 Incompatibility with materials of construction, and

X1.1.12 Velocity of flow.

X1.1.13 A decrease in dielectric strength of the insulating liquid can have an accentuated effect on the electric creepage strength of the solid insulating materials immersed in the insulating liquid.

X1.2 Because of the separate, cumulative, and in some cases, interacting effects of the influences listed above, the average breakdown voltage of a liquid as determined by this test method cannot be used directly for design purposes. Procedures utilizing electrode shapes and configurations similar to those used in insulating liquid filled apparatus are used to determine design data and to study the influence of the variables. However, test results utilizing the rounded electrodes in this test method do give an indication of the relative dielectric strength of the insulating liquid in the insulation system.

SUMMARY OF CHANGES

Committee D27 has identified the location of selected changes to this standard since the last issue (D1816-04) that may impact the use of this standard.

(1) Revised title to include other insulating liquids (silicone fluids, natural and synthetic esters).

(2) Changed the volume requirement for the test cell in **6.1**.

(3) Added Requirements for handling samples containing free water in **8.1**.

(4) Added hold time for testing natural and synthetic esters and high fire point fluids in **9.3**.

(5) Removed the standard deviation calculation and added Range calculation in **9.4** and **9.5**.

(6) Added Instructions for handling test results when they exceed the allowable range and there is insufficient sample to retest.

ASTM International takes no position respecting the validity of any patent rights asserted in connection with any item mentioned in this standard. Users of this standard are expressly advised that determination of the validity of any such patent rights, and the risk of infringement of such rights, are entirely their own responsibility.

This standard is subject to revision at any time by the responsible technical committee and must be reviewed every five years and if not revised, either reapproved or withdrawn. Your comments are invited either for revision of this standard or for additional standards and should be addressed to ASTM International Headquarters. Your comments will receive careful consideration at a meeting of the responsible technical committee, which you may attend. If you feel that your comments have not received a fair hearing you should make your views known to the ASTM Committee on Standards, at the address shown below.

This standard is copyrighted by ASTM International, 100 Barr Harbor Drive, PO Box C700, West Conshohocken, PA 19428-2959, United States. Individual reprints (single or multiple copies) of this standard may be obtained by contacting ASTM at the above address or at 610-832-9585 (phone), 610-832-9555 (fax), or service@astm.org (e-mail); or through the ASTM website (www.astm.org). Permission rights to photocopy the standard may also be secured from the Copyright Clearance Center, 222 Rosewood Drive, Danvers, MA 01923, Tel: (978) 646-2600; <http://www.copyright.com/>