



Standard Test Method for Climbing Drum Peel for Adhesives¹

This standard is issued under the fixed designation D1781; the number immediately following the designation indicates the year of original adoption or, in the case of revision, the year of last revision. A number in parentheses indicates the year of last reapproval. A superscript epsilon (ϵ) indicates an editorial change since the last revision or reapproval.

This standard has been approved for use by agencies of the U.S. Department of Defense.

1. Scope

1.1 This test method covers the determination of the peel resistance of adhesive bonds between: a relatively flexible adherend and a rigid adherend; and the relatively flexible facing of a sandwich structure and its core, when tested under specified conditions.

1.2 The values stated in SI units are to be regarded as the standard. The values given in parentheses are for information only.

1.3 *This standard does not purport to address all of the safety concerns, if any, associated with its use. It is the responsibility of the user of this standard to establish appropriate safety and health practices and determine the applicability of regulatory limitations prior to use.*

2. Referenced Documents

2.1 *ASTM Standards*:²

[B209 Specification for Aluminum and Aluminum-Alloy Sheet and Plate](#)

[D907 Terminology of Adhesives](#)

[E4 Practices for Force Verification of Testing Machines](#)

2.2 *ASTM Adjuncts*:

[Climbing Drum Peel Tester](#)³

3. Terminology

3.1 *Definitions*—Many of the terms used in this test method are defined in Terminology [D907](#).

¹ This test method is under the jurisdiction of ASTM Committee [D14](#) on Adhesives and is under the jurisdiction of Subcommittee [D14.80](#) on Metal Bonding Adhesives.

Current edition approved May 1, 2012. Published May 2012. Originally approved in 1960. Last previous edition approved in 2004 as D1781 – 98 (2004). DOI: 10.1520/D1781-98R12.

² For referenced ASTM standards, visit the ASTM website, www.astm.org, or contact ASTM Customer Service at service@astm.org. For *Annual Book of ASTM Standards* volume information, refer to the standard's Document Summary page on the ASTM website.

³ Detailed working drawings for the apparatus illustrated are available from ASTM International Headquarters. Order Adjunct No. [ADJD1781](#). Original adjunct produced in 1960.

4. Summary of Test Method

4.1 Determine the peeling force of a conditioned adhesive bonded sandwich assembly by peeling a face skin around a circular drum. This is done by clamping the assembly in a universal test machine. The average peeling load is determined using a standard formula.

5. Significance and Use

5.1 This test method may be used to determine comparative rather than fundamental measurements of adhesion and is particularly suitable for process control, some examples of which are listed.

5.1.1 This test method is particularly sensitive to adherend surface preparation and is of value where the adhesive is used in conjunction with a primer.

5.1.2 When a relatively brittle adhesive is used, the peel resistance can often give an indication of the degree of cure, that is, higher values than normally realized may indicate an incomplete cure. Direct comparison of different adhesives or processes can only be made when specimen design and test conditions are identical.

6. Apparatus

6.1 *Peeling Apparatus*, consisting of a flanged drum, flexible loading straps or cables, and suitable clamps for holding the test specimen. The apparatus illustrated in [Fig. 1](#) has been found to be satisfactory.

6.1.1 The outside radius of the drum is 51.00 ± 0.13 mm (2.000 ± 0.005 in.), and the radius of the flange, including one half of the thickness of the loading straps or cables, is 12.70 ± 0.13 mm (0.500 ± 0.005 in.) larger than the radius of the drum. This 12.70 ± 0.13 mm (0.500 ± 0.005 in.) less half the thickness of the adherend to be peeled, is the effective torque arm of the apparatus.

6.1.2 Use a suitable top clamp ([Fig. 2](#)) for supporting the specimen, and a drum clamp ([Fig. 3](#)) to hold the adherend against the face of the drum.

6.1.3 Balance the drum about the axis by the use of counterweights (as shown in [Fig. 1](#)) placed diametrically opposite the drum clamp to compensate for the weight of this clamp.

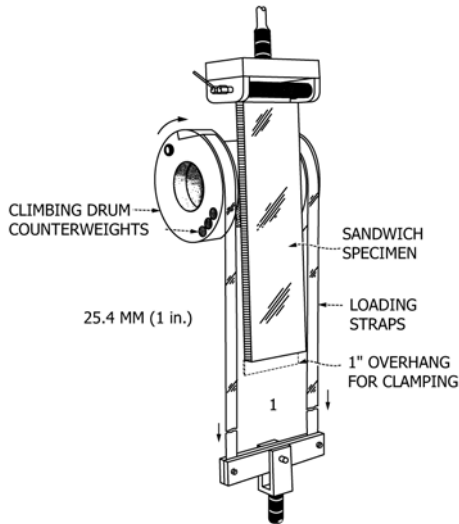

FIG. 1 Assembly of Peeling Apparatus

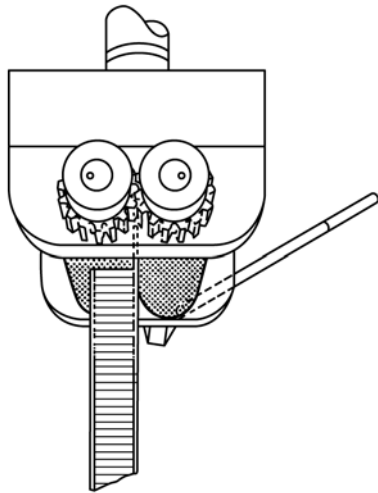

FIG. 2 Top Clamp

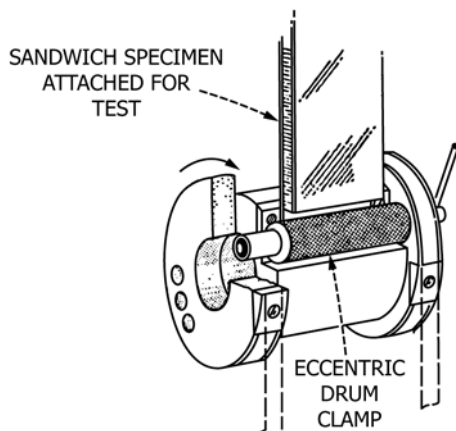

FIG. 3 Drum Clamp

6.1.4 The drum and flanges with the drum clamp and its compensating weight weighs ≤ 3.6 kg (8 lb), a lighter weight being preferable to facilitate handling of the apparatus.^{4,3}

6.2 *Testing Machine*, capable of applying tensile loads under the conditions prescribed in Section 11 and with the following further requirements:

6.2.1 The rate of movement between heads of the testing machine remains essentially constant under fluctuating loads (Note 1).

6.2.2 The testing machine weighs the load to within 1 %. The testing machine and range are selected such that the maximum load on the specimen falls between 15 and 85 % of the full-scale capacity.

6.2.3 The use of autographic equipment to record load versus head movement is recommended.

6.2.4 Verification of the testing machine is made in accordance with the recommendations of Practices E4.

NOTE 1—It is difficult to meet this requirement when loads are measured with a spring-type or pendulum-type weighing device.

7. Test Specimen

7.1 For evaluation of adhesives in laminated assemblies, a specimen of the type shown in Fig. 4 has been found to be satisfactory. The specimen is 25 mm (1 in.) wide between saw kerfs and at least 254 mm (10 in.) long. The specimen may be cut from larger bonded panels if desired.

7.2 For evaluation of adhesives in sandwich constructions, make the test specimens in conformance to the general form of the specimen shown in Fig. 1. The specimen is 76 mm (3 in.) wide by at least 305 mm (12 in.) long, including about a 25-mm (1-in.) overhang of one facing at each end. Thickness of the core is not important, except in the sense that the sandwich specimen does not bend while the facing is being peeled. For comparative evaluation of adhesives in bonding metal-faced sandwich constructions, a facing of clad aluminum alloy meeting the requirements of Specification B209, Alloy 2024-T3, 0.51 mm (0.020 in.) thick with a core 12.7 mm (0.5 in.) thick, has been found to be suitable. Other metal facings of comparable flexibility may also be used. The specimens may be cut from larger bonded panels if desired.

NOTE 2—Direct comparisons of different adhesives can be made only when specimen design and test conditions are identical.

7.3 Test at least six specimens, for example, two or more from each of three bonded panels, for each adhesive sample.

7.4 For sandwich constructions based on orthotropic cores, peel half of the specimens parallel to the length direction of the core and half parallel to the width direction, as determined from the configuration of the cell structure.

8. Preparation of Test Specimen

8.1 Do all preconditioning or special preparation of the adherends in accordance with the recommendations of the manufacturer of the adhesive.

⁴ A suitable climbing drum peel apparatus is available from Custom Scientific Instruments, Inc., 13 Wing Drive, Whippany, NJ, 07981.

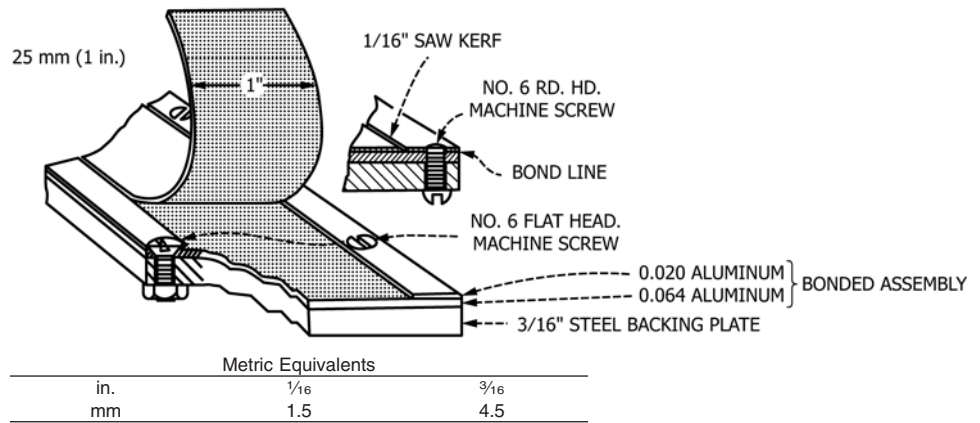

FIG. 4 Test Specimen for Laminated Assemblies

8.2 Bond in accordance with the procedure and recommendations prescribed by the manufacturer of the adhesive.

NOTE 3—Other preconditioning, preparation, and bonding conditions may be used if agreeable to the supplier and the purchaser of the adhesive.

8.3 Cut specimens from the sandwich panels or laminated panels in such a way as to avoid overheating or mechanical damage to the bond.

NOTE 4—A metal-cutting bandsaw has been found suitable for aluminum-alloy specimens of the types illustrated. The kerfs in laminate assemblies may be cut with a metal-cutting circular saw or milling cutter.

8.4 Attach laminated assemblies to the backing plate in such a manner that the surface to be peeled has no projections. This is done by drilling and tapping the specimen and attaching it by means of No. 6 machine screws inserted from the back side as shown in Fig. 4. Alternatively, with thick assemblies, holes in the specimen are counterbored, and flathead machine screws are then inserted through the specimen and backing plate and held with nuts on the back surface. This permits the use of slotted holes in the backing plate to accommodate less accurately spaced holes in the specimen. In some cases, it is possible to bond the specimen to the backing plate.

9. Calibration of Test Apparatus

9.1 Determine the load to overcome the resisting torque, F_0 (12.2), of drum, clamp, and counterweight, by one of the following methods:

9.1.1 For peel resistance of adhesive with no compensation for bending of adherend, insert a strip of fabric 0.20 to 0.28 mm (0.008 to 0.011 in.) thick and having negligible stiffness in place of the specimen, and apply a load sufficient to roll the drum upward on the fabric. With the drum dimensions given in 6.1 this measured load is about four times the weight of the drum, clamp, and counterweight, if the weighing apparatus is balanced to zero at the start.

9.1.2 For peel resistance of the adhesive with compensation for bending of the adherend, substitute a piece of material of the same composition, properties, and dimensions as the adherend to be peeled in place of the thin fabric, and apply a load sufficient to roll the drum upward on the material. This method largely offsets the torque required to bend the adherend

in the peel test. The forces imposed on the adherend during the peel test usually result in greater bending than is obtained in bending the unbonded adherend around the drum. More torque is required, therefore, to bend a bonded than an unbonded material; hence, this compensation is only approximate.

10. Conditioning

10.1 Condition specimens for 7 days at a relative humidity of $50 \pm 2\%$ and a temperature of $23 \pm 1^\circ\text{C}$ ($73.4 \pm 1.8^\circ\text{F}$), except when the adhesive manufacturer specifies that this conditioning period is unnecessary and that a shorter period is adequate. The manufacturer may also specify that a longer period is necessary.

10.2 Conditioning is not required for laminated assemblies containing only metal adherends, unless specified by the adhesive manufacturer as part of the bonding procedure.

11. Procedure

11.1 Clamp the test specimen securely to the drum by means of the drum clamp as shown in Fig. 3, and attach the other end of the specimen in the top clamp as shown in Fig. 1 and Fig. 2. Attach a suitable rigid backing plate to each laminate specimen. See 8.4 for suggested methods of attachment. Suspend the top clamp from the upper head of the testing machine. Balance the weighing apparatus to zero. Then pin the loading bar to the appropriate fittings on the lower head of the testing machine as shown in Fig. 1.

11.2 Apply an initial load, equal to that obtained in the calibration of the apparatus for load to overcome the resisting torque of the drum assembly, by loading the apparatus in tension. Determine the peel resistance over at least 152 mm (6 in.) of the bond by loading the apparatus in tension at a crosshead speed of 25.40 ± 2.54 mm/min (1.00 ± 0.10 in./min).

NOTE 5—A crosshead speed of 25 mm/min (1 in./min) peels the flexible member from the assembly at a rate of 102 mm/min (4 in./min), using the specified drum dimensions.

11.3 It is preferred that an autographic recording of the load versus head movement or load versus distance peeled be made during the peel test. If autographic equipment is not used,

average loads are obtained by recording the load at fixed increments of time (or of head motion) after the initial peak. For example, operating at a crosshead speed of 25 mm (1 in.)/min, the load is recorded 15 s after the start of the test and at each 5-s interval thereafter until approximately 152 mm (6 in.) of the specimen have been peeled. This permits calculating an average load over 127 mm (5 in.) of peeling, as described in 12.2.

12. Calculation

12.1 Determine the average peeling load required to peel the adherend from the autographic curve for the 127 mm (5 in.) of peeling of the specimen between 25 and 152 mm (1 and 6 in.), corresponding to 0.25 to 1.5 in. of head travel. It is preferred that the average be determined from the curve with the use of a planimeter. In case a planimeter is not used, calculate the average as the average of load readings taken at fixed increments of time or crosshead motion as indicated in 11.3.

12.2 Calculate the average peel torque, T , as follows:

$$\bar{T} = [(r_o - r_i)(F_p - F_o)]/W \quad (1)$$

where:

- \bar{T} = average peel torque, mm·kg/mm (in.·lb/in.) of width,
- r_o = radius of flange, including one half the thickness of the loading straps, mm (in.),
- r_i = radius of drum plus one half the thickness of the adherend being peeled, mm (in.),
- F_p = average load required to bend and peel adherend plus the load required to overcome the resisting torque, kg (lb),
- F_o = load required to overcome the resisting torque, in pounds (use load correction determined in 9.1.1 or 9.1.2, and
- W = width of specimen, in mm (in.).

13. Report

13.1 Report the following:

13.1.1 Complete identification of the adhesive tested, including type, source, manufacturer's code number, form, etc.,

13.1.2 Complete description of the adherends, their orientation and thicknesses, the method used for preparing their surfaces for bonding, and dimensions and construction of the test specimen used,

13.1.3 Application and bonding conditions used in preparing the test specimens and conditions used for cutting individual test specimens,

13.1.4 Conditioning procedure used for specimens prior to testing,

13.1.5 Test machine and machine head speed used with method of recording load and determining average load,

13.1.6 Number of specimens tested and number of test panels represented,

13.1.7 Method of calibration of test apparatus and load required to overcome the resisting torque of the particular drum assembly used, in accordance with 9.1.1 or 9.1.2,

13.1.8 Average, maximum, and minimum peeling load values for each individual specimen,

13.1.9 Average peel torque in millimetre-kilograms per millimetre (inch-pounds per inch) of specimen width for each specimen, and average values for each group of similar specimens, and

13.1.10 Type of failure, that is, cohesive failure within the adhesive, adhesion to the facing, adhesion to the core, failure within the core, or combinations thereof for each individual specimen.

14. Precision and Bias

14.1 A precision and bias statement does not exist for this test method because resources necessary for round-robin testing have not been forthcoming.

15. Keywords

15.1 adhesives; climbing drum; peel strength; peel tests; sandwich panel

ASTM International takes no position respecting the validity of any patent rights asserted in connection with any item mentioned in this standard. Users of this standard are expressly advised that determination of the validity of any such patent rights, and the risk of infringement of such rights, are entirely their own responsibility.

This standard is subject to revision at any time by the responsible technical committee and must be reviewed every five years and if not revised, either reapproved or withdrawn. Your comments are invited either for revision of this standard or for additional standards and should be addressed to ASTM International Headquarters. Your comments will receive careful consideration at a meeting of the responsible technical committee, which you may attend. If you feel that your comments have not received a fair hearing you should make your views known to the ASTM Committee on Standards, at the address shown below.

This standard is copyrighted by ASTM International, 100 Barr Harbor Drive, PO Box C700, West Conshohocken, PA 19428-2959, United States. Individual reprints (single or multiple copies) of this standard may be obtained by contacting ASTM at the above address or at 610-832-9585 (phone), 610-832-9555 (fax), or service@astm.org (e-mail); or through the ASTM website (www.astm.org). Permission rights to photocopy the standard may also be secured from the Copyright Clearance Center, 222 Rosewood Drive, Danvers, MA 01923, Tel: (978) 646-2600; http://www.copyright.com/