



Designation: D1709 – 16a<sup>ε1</sup>

# Standard Test Methods for Impact Resistance of Plastic Film by the Free-Falling Dart Method<sup>1</sup>

This standard is issued under the fixed designation D1709; the number immediately following the designation indicates the year of original adoption or, in the case of revision, the year of last revision. A number in parentheses indicates the year of last reapproval. A superscript epsilon ( $\epsilon$ ) indicates an editorial change since the last revision or reapproval.

*This standard has been approved for use by agencies of the U.S. Department of Defense.*

<sup>ε1</sup> NOTE—Editorially corrected Fig. 1 in April 2017.

## 1. Scope\*

1.1 These test methods cover the determination of the energy that causes plastic film to fail under specified conditions of impact of a free-falling dart. This energy is expressed in terms of the weight (mass) of the missile falling from a specified height which would result in 50 % failure of specimens tested.

1.2 Two test methods are described:

1.2.1 *Test Method A* employs a dart with a  $38.10 \pm 0.13$ -mm ( $1.500 \pm 0.005$ -in.) diameter hemispherical head dropped from a height of  $0.66 \pm 0.01$  m ( $26.0 \pm 0.4$  in.). This test method can be used for films whose impact resistances require masses of about 50 g or less to about 6 kg to fracture them.

1.2.2 *Test Method B* employs a dart with a  $50.80 \pm 0.13$ -mm ( $2.000 \pm 0.005$ -in.) diameter hemispherical head dropped from a height of  $1.52 \pm 0.03$  m ( $60.0 + 0.25, -1.70$  in.). Its range of applicability is from about 0.3 kg to about 6 kg.

1.3 Two testing techniques are described:

1.3.1 The standard technique is the staircase method. By this technique, the missile weight employed during the test is decreased or increased by uniform increments after the testing of each specimen, depending upon the result (fail or not fail) observed for the specimen.

1.3.2 The alternative technique provides for testing specimens in successive groups of ten. One missile weight is employed for each group and the missile weight is varied in uniform increments from group to group.

1.3.3 The staircase technique and the alternative technique give equivalent results both as to the values of impact failure weight which are obtained and as to the precisions with which they are determined.

<sup>1</sup> These test methods are under the jurisdiction of ASTM Committee D20 on Plastics and are the direct responsibility of Subcommittee D20.19 on Film, Sheeting, and Molded Products.

Current edition approved May 1, 2016. Published May 2016. Originally approved in 1959. Last previous edition approved in 2016 as D1709 – 16. DOI: 10.1520/D1709-16AE1.

1.4 The values stated in SI units are to be regarded as standard. The values stated in parentheses are for information only.

NOTE 1—Tests on materials that do not break, for any reason, are not considered to be valid. It has been noted that certain materials may stretch so far as to bottom out at the base of certain test instruments without actually rupturing. Subcommittee D20.19 is currently considering methods for testing these materials. Anyone interested in participating in a Task Group should contact the Chairman of Subcommittee D20.19 through ASTM International Headquarters.

1.5 *This standard does not purport to address the safety concerns, if any, associated with its use. It is the responsibility of the user of this standard to establish appropriate safety and health practices and determine the applicability of regulatory limitations prior to use.*

NOTE 2—Film has been arbitrarily defined as sheeting having nominal thickness not greater than 0.25 mm (0.010 in.).

NOTE 3—This test method is technically equivalent to ISO 7765-1:1988, with the exception of a larger tolerance on the drop height in Test Method B, smaller tolerances on the dart diameters for Test Methods A and B, and the requirement for a vented dart well in 5.1.1. Also, the ISO method does not allow the alternative testing technique described in Section 11 of this test method.

1.6 *This international standard was developed in accordance with internationally recognized principles on standardization established in the Decision on Principles for the Development of International Standards, Guides and Recommendations issued by the World Trade Organization Technical Barriers to Trade (TBT) Committee.*

## 2. Referenced Documents

2.1 *ASTM Standards:*<sup>2</sup>

D618 Practice for Conditioning Plastics for Testing

D883 Terminology Relating to Plastics

D1248 Specification for Polyethylene Plastics Extrusion Materials for Wire and Cable

<sup>2</sup> For referenced ASTM standards, visit the ASTM website, www.astm.org, or contact ASTM Customer Service at service@astm.org. For *Annual Book of ASTM Standards* volume information, refer to the standard's Document Summary page on the ASTM website.

\*A Summary of Changes section appears at the end of this standard

- [D3420 Test Method for Pendulum Impact Resistance of Plastic Film](#)
- [D4272 Test Method for Total Energy Impact of Plastic Films by Dart Drop](#)
- [D6988 Guide for Determination of Thickness of Plastic Film Test Specimens](#)
- [E177 Practice for Use of the Terms Precision and Bias in ASTM Test Methods](#)
- [E691 Practice for Conducting an Interlaboratory Study to Determine the Precision of a Test Method](#)
- 2.2 *ISO Standard:*
- [ISO 7765:1988 Plastic Film and Sheet—Determination of Impact Resistance by the Free Falling Dart Method—Part 1: Staircase Method<sup>3</sup>](#)

### 3. Terminology

3.1 *Definitions*—For definitions related to plastics, see Terminology [D883](#).

3.2 *Definitions of Terms Specific to This Standard:*

3.2.1 *failure*—any break through the film that can be observed readily by feeling or by viewing the specimen under backlighted condition.

3.2.2 *impact failure weight*—that missile weight, estimated statistically, at which 50 % of the specimens would fail in the specified test.

3.2.3 *missile weight*—the weight (mass) of the dart plus the total value of incremental weights attached *plus* the locking collar.

### 4. Significance and Use

4.1 Test Methods A and B are used to establish the weight of the dart when 50 % of the specimens fail under the conditions specified. Data obtained by one test method cannot be compared directly with the other test method nor with those obtained from tests employing different conditions of missile velocity, impinging surface diameter, effective specimen diameter, material construction and finish of the dart head, and film thickness. The values obtained by these test variables are highly dependent on the method of film fabrication.

4.2 The results obtained by Test Methods A and B are greatly influenced by the quality of film under test. The confidence limits of data obtained by this procedure can, therefore, vary significantly, depending on the sample quality, uniformity of film gage, die marks, contaminants, etc. (see Section [15](#)).

4.3 Test Methods A and B have been found useful for specification purposes.

NOTE 4—With sufficient data, correlation between test results and field performance can usually be established.

4.4 The impact resistance of plastic film, while partly dependent on thickness, has no simple correlation with sample thickness. Hence, impact values cannot be normalized over a range of thickness without producing misleading data as to the

actual impact resistance of the material. Data from these test methods are comparable only for specimens that vary by no more than  $\pm 25$  % from the nominal or average thickness of the specimens tested.

4.5 Several impact test methods are used for film. It is sometimes desirable to know the relationships among test results derived by different test methods. A study was conducted in which four films made from two resins (polypropylene and linear low-density polyethylene), with two film thicknesses for each resin, were impacted using Test Methods D1709 (Method A), [D3420](#) (Procedures A and B), and [D4272](#). The test results are shown in the Appendix. Differences in results between Test Methods D1709 and [D4272](#) are not unusual since Test Methods D1709 represents failure initiated energy, while Test Method [D4272](#) is initiation plus completion energy. Some films exhibit consistency when the initiation energy is the same as the total energy. This statement and the test data also appear in the significance sections and appendixes of Test Methods [D3420](#) and [D4272](#).

### 5. Apparatus

5.1 The apparatus shall be constructed essentially as shown in [Fig. 1](#), using the following components common to both test methods:

5.1.1 *Dart Well*—If the dart impact machine utilizes an enclosed dart well, it must contain a single unobstructed vent with a minimum area of 625 mm<sup>2</sup> (~1 in.<sup>2</sup>) to provide adequate venting.

NOTE 5—Some dart impact machine designs utilize enclosed dart wells that do not permit adequate venting to the atmosphere during impact. Data have shown that this has a significant effect on the observed impact value, especially with films that exhibit high elongation during testing, resulting in atypically high impact values.

NOTE 6—The use of smaller, multiple vents is permitted if it can be demonstrated that the venting efficiency is comparable and has no statistically significant effect on the values obtained.

5.1.2 *Specimen Clamp*—A two-piece annular specimen clamp having an inside diameter of 125  $\pm$  2.0 mm (5.0 + 0.0, -0.15 in.) and conforming to the following requirements:

5.1.2.1 The lower or stationary half of the clamp shall be mounted rigidly so that the plane of the specimen is horizontal.

5.1.2.2 The upper or movable part of the clamp shall be designed to maintain positive and plane contact with the lower part of the clamp when in position. The clamps shall be provided with suitable means of maintaining sufficient contact to hold the film sample firmly in place during the test. Pneumatically operated clamps have been successfully employed.

5.1.2.3 Rubber-like gaskets can be affixed to the specimen contact surfaces of both clamps to provide a cushion which minimizes thickness variation effects. Rubber gasketing 3.18  $\pm$  1 mm (0.125 + 0.025, -0.04 in.) thick, of 50 to 60 Shore A durometer hardness, 125  $\pm$  2.0 mm (5.00 + 0.00, -0.15 in.) in inside diameter and 152  $\pm$  3.0 mm (6.0 + 0.02, -0.2 in.) in outside diameter has been found satisfactory for this purpose.

5.1.2.4 To minimize or eliminate slippage of films greater than 0.10 mm (0.004 in.) in thickness, crocus cloth or 50D garnet abrasive paper can be secured to the gaskets with double-sided tape so that the abrasive surface is in direct

<sup>3</sup> Available from American National Standards Institute (ANSI), 25 W. 43rd St., 4th Floor, New York, NY 10036, <http://www.ansi.org>.

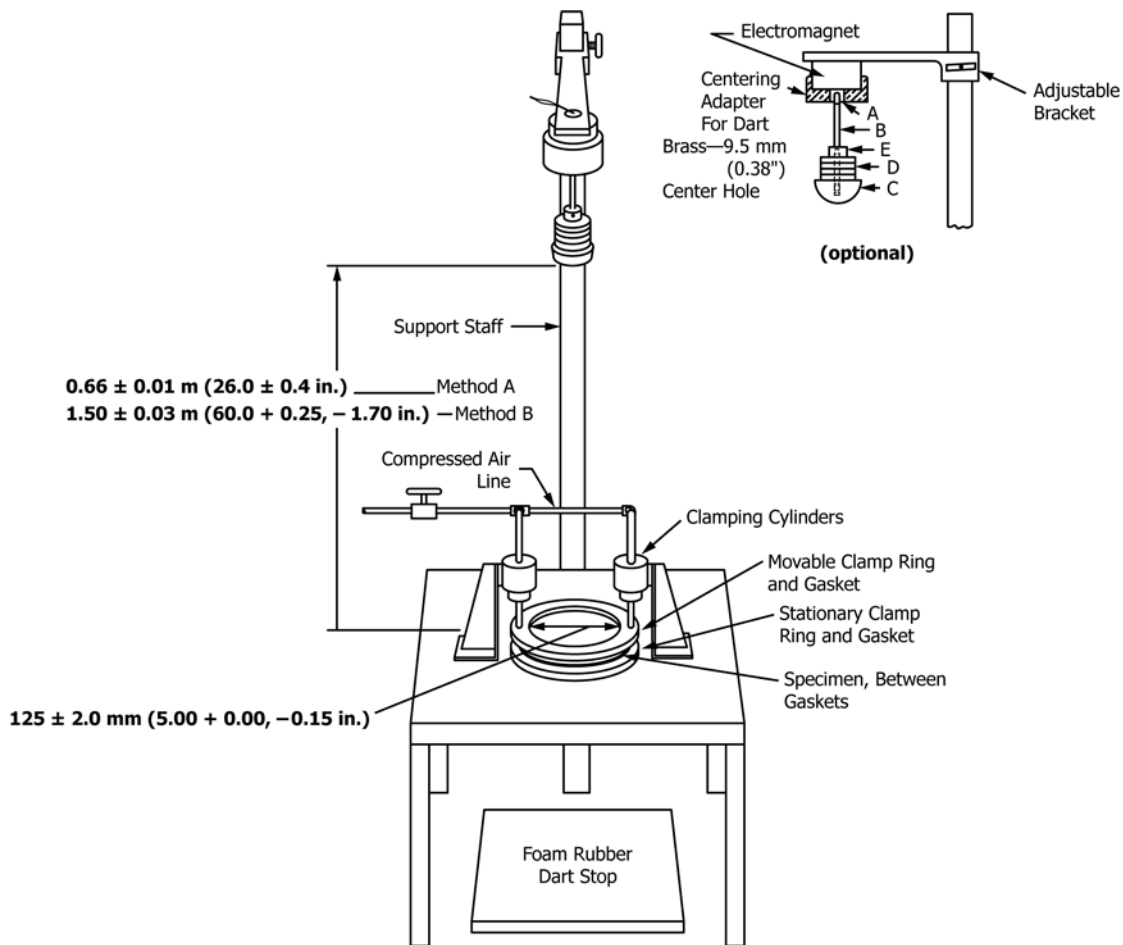

NOTE 1—Values for tolerances in SI units are to be regarded as standard. The numbers in parentheses reflect the allowable tolerance range of older equipment and are only provided for information and, in many cases, do not correspond directly to the tolerances in SI units. The differences are not expected to have a significant effect on the results but the dimensions in SI units shall be used in cases of dispute.

NOTE 2—Legend Dart Assembly:

- A. Steel shaft tip  $6.5 \pm 1$  mm ( $0.25 + 0.04, -0.03$  in.) OD by  $12.5 \pm 0.2$  mm ( $0.50 + 0.00, -0.02$  in.) long.
- B. Dart shaft:  $6.5 \pm 1$  mm ( $0.25 + 0.04, -0.03$  in.) OD and at least 115 mm (4.5 in.) long:  $\frac{1}{4}$ –20 thd. (N.C.)  $12.5 \pm 0.2$  mm ( $0.50 + 0.00, -0.02$  in.) long on bottom: No. 5–40 thd. (N.F.) for steel tip.
- C. Hemispherical head: Method A— $38.10 \pm 0.13$ –mm ( $1.500 \pm 0.005$ –in.) in diameter. Method B— $50.80 \pm 0.13$ –mm ( $2.000 \pm 0.005$  in.) in diameter.
- D. Removable weights.
- E. Collar and screw.

FIG. 1 Apparatus for Free-Falling Dart Impact Test for Plastic Film

contact with the film. The clamping force shall be sufficient to eliminate any detectable slippage. Other means of reducing slippage such as additional clamping devices or positive clamping surfaces are also acceptable provided that the film is not weakened at the inside wall of the specimen clamps and that the effective diameter of  $125 \pm 2.0$  mm ( $5.00 + 0.00, -0.15$  in.) of the film is not changed.

5.1.3 *Dart Release Mechanism*, capable of supporting the heaviest weight utilized for testing (up to 6 kg) shall be used for supporting and releasing the dart assembly. It shall be equipped with a centering device, such as a removable plumb bob, to ensure a reproducible drop. Either an electromagnetic- or pneumatic-operated release mechanism is acceptable.

5.1.4 *Positioning Device*—The apparatus shall be able to drop the dart from heights of  $0.66 \pm 0.01$  m ( $26.0 \pm 0.4$  in.) for Test Method A and  $1.52 \pm 0.03$  m ( $60.0 + 0.25, -1.70$  in.) for Test Method B. The distance between the impinging surface

of the dart head and the surface of the test specimen is considered to be the drop height. The dart shall be positioned vertically above the center of the test specimen.

5.1.5 *Micrometer, or other suitable thickness gauge*, for measuring specimen thickness in accordance with Guide D6988.

5.1.6 *Cushioning and Shielding Devices*, to protect personnel and to avoid damaging the impinging surface of the dart. These devices shall not interfere with the dart or the specimen prior to penetrating the specimen.

5.1.7 *Collar* with inside diameter of approximately 7 mm (0.28 in.) and with set screw for securing collar to dart shaft.

5.2 *Darts* for Test Methods A and B shall have hemispherical heads, each fitted with a  $6.4 \pm 1$ -mm ( $0.25 + 0.04, -0.03$ -in.) diameter shaft at least 114.3 mm (4.5 in.) long to accommodate removable incremental weights. Each dart

weight shall be known to  $\pm 0.5\%$  relative. Dart head surfaces shall be free of nicks, scratches, or other irregularities. The shaft shall be attached to the center of the flat surface of the head with its longitudinal axis perpendicular to the surface. If an electromagnet is used, the shaft shall be made of material that is not magnetic and shall have a steel tip  $12.7 \pm 0.2$  mm ( $0.50 + 0.00, -0.02$  in.) long at the end held by the electromagnet.

5.2.1 For Test Method A, the dart head shall be  $38.10 \pm 0.13$ –mm ( $1.500 \pm 0.005$ –in.) in diameter.

5.2.2 For Test Method B, the dart head shall be  $50.80 \pm 0.13$ –mm ( $2.000 \pm 0.005$  in.) in diameter.

5.2.3 Acceptable materials of construction include smooth, polished stainless steel, phenolic, composite, or other material of similar hardness and durability. The material of construction of the dart head shall be referenced in the report using the following designations:

Material Construction	Designation
Stainless Steel	A
Aluminum	B
Phenolic	C
Composite	D
Other	E

NOTE 7—Data have shown a sensitivity of impact results related to the material of construction and finish of the dart head used. The differences have been especially significant when testing films exhibiting high impact, or high elongation characteristics, or both. This issue, together with related concerns, is currently under study in Subcommittee D20.19.

5.3 *Incremental Weights* for Test Methods A and B shall be of stainless steel or brass and cylindrical in shape. Each shall have a center hole  $6.6 + 1.0, -0.00$  mm ( $0.26 + 0.03, -0.00$  in.) in diameter. The thickness of each shall be adjusted to obtain the specified weight within  $\pm 0.5\%$ . The diameter of the weights shall not exceed the diameter of the dart head. Suggested combination of weights for the specified diameters are as follows:

5.3.1 For Test Method A,  $31.75 \pm 1$ –mm ( $1.25 + 0.03, -0.05$ –in.) diameter weights.

Number	Weight, g
2 or more	5
8	15
8	30
8	60

5.3.2 For Test Method B,  $44.5 \pm 1$ –mm ( $1.75 + 0.06, -0.02$ –in.) diameter weights.

Number	Weight, g
2 or more	15
8	45
8	90

5.3.3 Optionally, additional weights, each  $120$  g  $\pm 0.5\%$  for Test Method A or  $180$  g  $\pm 0.5\%$  for Test Method B, are acceptable for use if it is necessary to extend the missile weight beyond that attainable when using all weights in the standard set.

## 6. Test Specimen

6.1 Test specimens shall be large enough to extend outside the specimen clamp gaskets at all points. The specimens shall be representative of the film under study and shall be taken from the sheet or tube in a manner representative of sound sampling practice. This is to ensure that the whole of the sheet be represented in the test unless such sampling constitutes a variable under study.

6.2 The specimens shall be free of pinholes, wrinkles, folds, or other obvious imperfections, unless such imperfections constitute variables under study.

## 7. Conditioning

7.1 *Conditioning*—Condition the test specimens at  $23 \pm 2^\circ\text{C}$  ( $73.4 \pm 3.6^\circ\text{F}$ ) and  $50 \pm 10\%$  relative humidity for not less than 40 h prior to test in accordance with Procedure A of Practice D618 unless otherwise specified by agreement or the relevant ASTM material specification. In cases of disagreement, the tolerances shall be  $\pm 1^\circ\text{C}$  ( $\pm 1.8^\circ\text{F}$ ) and  $\pm 5\%$  relative humidity.

7.2 *Test Conditions*—Conduct the tests at  $23 \pm 2^\circ\text{C}$  ( $73.4 \pm 3.6^\circ\text{F}$ ) and  $50 \pm 10\%$  relative humidity unless otherwise specified by agreement or the relevant ASTM material specification. In cases of disagreement, the tolerances shall be  $\pm 1^\circ\text{C}$  ( $\pm 1.8^\circ\text{F}$ ) and  $\pm 5\%$  relative humidity.

## 8. Preparation of Apparatus

8.1 Set up the apparatus for testing by Test Method A or by Test Method B.

8.1.1 For Test Method A select a dart with a  $38.10 \pm 0.13$ –mm ( $1.500 \pm 0.005$ –in.) diameter hemispherical head. For Test Method B, select a dart with a  $50.80 \pm 0.13$ –mm ( $2.000 \pm 0.005$ –in.) diameter hemispherical head.

8.1.2 Inspect the die head for any visually obvious scratches or other imperfections. If present, reject the use of the die head.

8.1.3 Activate the dart release mechanism and insert the steel shaft tip into the mechanism. Ensure the dart is securely held in place by the dart release mechanism. Adjust the drop height (the vertical distance from the plane of a clamped specimen to the bottom surface of the dart head) to  $0.66 \pm 0.01$  m ( $26.0 \pm 0.4$  in.) for Test Method A or to  $1.52 \pm 0.03$  m ( $60.0 + 0.25, -1.70$  in.) for Test Method B. (**Warning**—For safety reasons, remove the dart while making position adjustments.)

8.1.4 With a trial film specimen clamped between the specimen clamps and with no added weights on the dart, release the dart and observe the point at which the dart impacts the specimen, catching the dart after it bounces off the film



surface. If necessary, adjust the dart release mechanism so that, in repeated trials, the dart reproducibly impacts the center of the clamped portion of the film.

8.2 Check the apparatus periodically to make sure specimen slippage during testing is not occurring (see 5.1.2.4). If slippage occurs, this is reason to reject the results.

NOTE 8—The likelihood of occurrence of slippage increases with increasing dart weight and with increasing drop height and is greater with some materials than with others.

Two methods to determine if slippage has occurred are described in the following notes.

NOTE 9—One method of conveniently checking slippage during the course of testing of a routine sample at a missile weight wherein both failures and non-failures are being observed consists of drawing a circle on the film using a ball-point pen or equivalent before dropping the missile on a clamped specimen, applying only the pressure of the pen itself to the film. After the dart is dropped and prior to removing the plastic film, draw another circle using a ball-point pen of another color. Evidence of distinct double lines at any point on the circumference show that slippage has occurred. (**Warning**—For safety reasons, remove the dart from the dart release mechanism while drawing the circle.)

NOTE 10—If crocus cloth or sandpaper is affixed to the gaskets to effect greater gripping, inspect the clamped film area after impact for evidence of scratch marks produced as slippage occurred.

## STAIRCASE TESTING TECHNIQUE

### 9. Procedure

9.1 By this technique, a uniform missile weight increment is employed during test and the missile weight is changed after test of each specimen.

9.2 Select Test Method A or Test Method B for use, as desired, or as required by the relevant product specification. Set up the apparatus for testing as described in 8.1. Conduct a slippage check as described in 8.2 at some point during the course of testing.

9.3 Measure and record the average thickness of the test specimens in the area of impact to the nearest 0.0025 mm (0.0001 in.).

9.4 For a starting point, select a missile weight near the expected impact failure weight. Add the necessary number of incremental weights onto the dart shaft and put the locking collar into place so that the weights are held securely in place.

9.5 Select a missile weight increment  $\Delta W$  appropriate to the impact strength of the sample: Choose a value for  $\Delta W$  so that at least three, but preferably six, missile weights will be employed in the determination.

NOTE 11—It has been found that a  $\Delta W$  value equal to some 5 to 15 % of  $W_F$ , the impact failure weight, is usually appropriate.

9.6 Place the first test specimen over the bottom part of the clamp, making sure that it is uniformly flat, free of folds, and that it covers the gasket at all points. Clamp in place with the top part of the annular clamp.

9.7 Activate the dart release mechanism and put the dart into position. Release the dart. If the dart bounces off the specimen surface, catch the dart after it bounces to prevent both multiple impact with the specimen surface and damage to

the hemispherical contact surface of the dart resulting from impact with metal parts of the apparatus.

9.8 Examine the test specimen for any evidence of slippage. If slippage occurs, this is reason to reject the results.

9.9 Examine the specimen to determine whether it has or has not failed. Record the result on a form such as that shown in Fig. 2, using a 0 to denote non-failure and an X to denote failure, or any other similar convention to indicate non-failure or failure.

9.10 If the first specimen failed, decrease the missile weight by  $\Delta W$ . If the first specimen did not fail, increase the missile weight by  $\Delta W$ . Test the second specimen. Continue testing successive specimens, decreasing or increasing the missile weight by  $\Delta W$  between drops depending upon whether the preceding specimen did or did not fail.

9.11 After 20 specimens have been tested, count the total number,  $N$ , of failures, (X's). If  $N = 10$  at this point, testing is complete. If not, complete testing as follows:

9.11.1 If  $N < 10$ , continue testing additional specimens until  $N = 10$ , then stop testing.

9.11.2 If  $N > 10$ , continue testing additional specimens until the total number of non-failures (0's) reaches 10, then stop testing.

### 10. Calculation

10.1 On the data record-calculation form (see Fig. 2), record under  $n_i$  the total number of X's at each missile weight, counting only the *last* 10 X's during test.

NOTE 12—If, during test, after 20 drops,  $N < 10$  or  $N = 10$ , there will be only 10 X's after testing is complete. Only where  $N > 10$  after 20 drops will it be necessary to omit some of the earlier X results.

10.2 Under  $i$ , enter integers 0, 1, 2, etc. for each  $n_i$  entry. Enter 0 for the lowest missile weight at which an  $n_i$  value has been entered, a 1 for next higher missile weight, etc.

10.3 Under  $in_i$ , enter the product of  $i$  times  $n_i$ .

10.4 Add the  $n_i$ 's and enter as  $N$ ; by the procedure described,  $N$  will always be 10. Add the  $in_i$ 's and enter as  $A$ . Enter  $W_o$ , the missile weight to which an  $i$  value of zero is assigned. Enter  $\Delta W$  the uniform missile weight increment employed.

10.5 Calculate the impact failure weight  $W_F$ , g, as follows:

$$W_F = W_o + [\Delta W(A/N - 1/2)]$$

## ALTERNATIVE TESTING TECHNIQUE

### 11. Procedure

11.1 By this technique, successive groups of ten specimens each are tested. For each group, one missile weight is employed and from group to group missile weight is varied in uniform increments. Testing is carried to a point where there are at least five results for percentage failure: one 0 % result, one 100 % result and at least three results between 0 and 100 %.

NOTE 13—In quality control work, it is possible to estimate  $W_F$  from fewer than five failure results at missile weights not necessarily uniformly spaced. Of these, no result can be 0 or 100 % failure, at least one result has

Sample : \_\_\_\_\_

Test Conditions :

Laboratory : \_\_\_\_\_

Note : O denotes non-failure  
X denotes failure

Method A (26 in., 1.5 in.)  
 Method B (60 in., 2.0 in.)

Operator : \_\_\_\_\_

Date : \_\_\_\_\_

Missile Weight, g														$n_i$	$i$	$in_i$	
165						X									1	3	3
150				O	X	X	X					X			4	2	8
135	X			O			O	O	X	X	O	X			4	1	4
120		X	O							O	O			O	1	0	0
105			O														

20

Sequential Results

$$N = \frac{10}{1} \quad A = \frac{15}{1}$$

$$W_o = \frac{120}{1} \quad \Delta W = \frac{15}{1}$$

NOTE 1—

$$W_F = W_o + [\Delta W (A/N - 1/2)]$$

$$= 120 + [15(15/10 - 1/2)]$$

$$= 120 + [15(1.5 - 0.5)]$$

$$= 135 \text{ g.}$$

**FIG. 2 Determination of Dart Impact Failure Weight**

to be less than 50 %, and at least one result should be greater than 50 %. Either the individual results or moving averages-of-two are plotted on probability paper (see 12.4), a straight line is fitted, and  $W_F$  is read from the plot. Values of  $W_F$  estimated in this manner will be unbiased but will not be as precise as values derived from at least five failure results employing uniform missile weight increments as previously described.

11.2 Select Test Method A or Test Method B for use, as desired, or as required by the relevant product specification. Set up the apparatus for testing in accordance with 8.1. Conduct a slippage check as described in 8.2 at some point during the course of testing.

11.3 Measure and record the average thickness of the test specimens in the area of impact to the nearest 0.0025 mm (0.0001 in.).

11.4 For a starting point, select a missile weight near the expected impact failure weight. Add the necessary number of incremental weights onto the dart shaft and put the locking collar into place so that the weights are held securely in place.

11.5 Place the first test specimen over the bottom part of the clamp, making sure that it is uniformly flat, free of folds, and that it covers the gasket at all points. Clamp in place with the top part of the annular clamp.

11.6 Activate the dart release mechanism and put the dart into position. Release the dart. If the dart bounces off the specimen surface, catch the dart after it bounces to prevent

both multiple impact with the specimen surface and damage to the hemispherical contact surface of the dart resulting from impact with metal parts of the apparatus.

11.7 Test a total of ten specimens at the selected starting missile weight. Record the missile weight and the percentage of failures.

11.8 If the failure result for the first group of ten specimens is 0 or 100 %, increase or decrease the missile weight by 15 g or more for Test Method A or 45 g or more for Test Method B and test another ten specimens as previously described. Continue in this manner until a failure result between 0 and 100 % is obtained. Continue testing groups of ten specimens, varying the missile weight between tests by the selected uniform increment, until results encompassing the entire range from 0 to 100 % failure inclusive have been obtained.

NOTE 14—For efficiency in testing, it is suggested that the missile weight increment selected initially be relatively large so that 0 and 100 % failure results will be found after testing only two or three groups of specimens. “Fill-in” results between the corresponding extremes of missile weight can then be obtained in subsequent testing.

11.9 At this stage, if the minimum five results described in 11.1 have been obtained, testing is complete. If not, select a new missile weight increment less than that employed initially. Test additional groups of specimens as previously described beginning at one weight increment below the lowest missile

weight at which 100 % failure occurred. Continue testing specimen groups at increasingly lower missile weights employing the new uniform increment, until a result of 0 % failure is obtained.

NOTE 15—One or more of the percentage points found in 11.8 may be usable in this series employing a smaller weight increment.

If the minimum five results have now been obtained, testing is complete. If not, select a still smaller weight increment and repeat the preceding process, continuing in this manner until the minimum five results at uniform weight increments have been obtained.

## 12. Calculation

12.1 Determine impact failure weight,  $W_F$ , by calculation as described in 12.2 or by graphing as described in 12.4. These two approaches give essentially the same results.

12.2 Calculate  $W_F$  as follows:

$$W_F = W_L - [\Delta W(S/100 - 1/2)]$$

where:

- $W_F$  = impact failure weight, g,
- $\Delta W$  = uniform weight increment used, g,
- $W_L$  = lowest missile weight, g, according to the particular  $\Delta W$  used, at which 100 % failure occurred, and
- $S$  = sum of the percentages of breaks at each missile weight (from a weight corresponding to no failures up to and including  $W_L$ ).

12.3 Example of calculation:

Given:	Missile Weight, g	% Failure
	91	0
	106	10
	121	20
	136	60
	151	100
		$S = 190$

$$\Delta W = 15 \text{ g}, W_L = 151 \text{ g}$$

$$\begin{aligned} W_F &= W_L - [\Delta W(S/100 - 1/2)] \\ &= 151 - [15(190/100 - 1/2)] \\ &= 151 - [15(1.4)] \\ &= 130 \text{ g} \end{aligned}$$

12.4 Average successive pairs of missile weight-percent failure results, including 0 % and 100 % failure points, to obtain points for plotting. Construct a plot on probability paper with percent failure on the probability scale and weight on the linear scale after having dimensioned the linear scale such that the resultant straight line defined by the points will have a slope between about 0.3 and 1.0. Draw the best fitting straight line through the points and read  $W_F$  from the graph as that missile weight corresponding to the intersection of the straight line with the 50 % probability line.

12.5 Examples of the graphical method for determining  $W_F$  are given in Fig. 3. For the three cases shown, values of  $W_F$  determined by calculation by 12.2 are (1) 138, (2) 117, and (3) 92 g.

## 13. Routine Inspection and Acceptance

13.1 For routine inspection of thin plastic film of a specified gage received from an approved supplier, it shall be satisfactory to accept lots on the basis of testing a minimum of ten specimens at a specified weight as stated in the relevant product specification. Under this procedure, a result of no more than five failures shall be acceptable.

## 14. Report

14.1 Report the following information:

14.1.1 Complete identification and description of the material tested, including type, source, manufacturer's code, principal dimensions, and previous history.

14.1.2 Impact failure weight, to the nearest 1 g,

14.1.3 Method used,

14.1.4 Designation of dart head material,

14.1.5 Thickness of film tested and range of thickness for specimens tested,

14.1.6 Conditioning procedure followed,

14.1.7 Testing technique used, and

14.1.8 Date of test.

14.2 For routine inspection and acceptance testing only (13.1) the following shall be reported, instead of items 14.1.2 and 14.1.6:

14.2.1 Weight used, and

14.2.2 Number of failures.

## 15. Precision and Bias<sup>4</sup>

**TABLE 1 Drop Dart Impact Data F-50**

NOTE 1—Values expressed in units of grams

Material	Average	$S_r^A$	$S_R^B$	$r^C$	$R^D$
Commercial Polyethylene	54	2.5	6.4	7.1	17.9
Polypropylene	78	8.4	14.1	23.6	39.4
EVA-film	328	83.6	120.3	234.2	336.9
LLDPE	372	30.4	111.1	85.2	311.1

<sup>A</sup>  $S_r$  = within-laboratory standard deviation for the indicated material. It is obtained by pooling the within-laboratory standard deviations of the test result from all of the participating laboratories:

$$S_r = [((S_1)^2 + (S_2)^2 \dots + (S_n)^2)/n]^{1/2}$$

<sup>B</sup>  $S_R$  = between-laboratories reproducibility, expressed as standard deviation:

$$S_R = [S_r^2 + S_L^2]^{1/2}$$

where:  $S_L$  is the standard deviation of laboratory means.

<sup>C</sup>  $r$  = within-laboratory critical interval between two test results =  $2.8 \times S_r$ .

<sup>D</sup>  $R$  = between laboratories critical interval between two test results =  $2.8 \times S_R$ .

15.1 Table 1 is based on a round robin conducted in 1989 in accordance with Practice E691, involving four materials tested by nine laboratories. For each material, all the samples were prepared at one source, but the individual specimens were prepared at the laboratories which tested them. Each test result was the average of five individual determinations. Each laboratory obtained two test results for each material. (**Warning**—The explanations of “ $r$ ” and “ $R$ ” (15.2 through 15.2.3) are only intended to present a meaningful way of considering the

<sup>4</sup> Supporting data have been filed at ASTM International Headquarters and may be obtained by requesting Research Report RR:D20-1024.

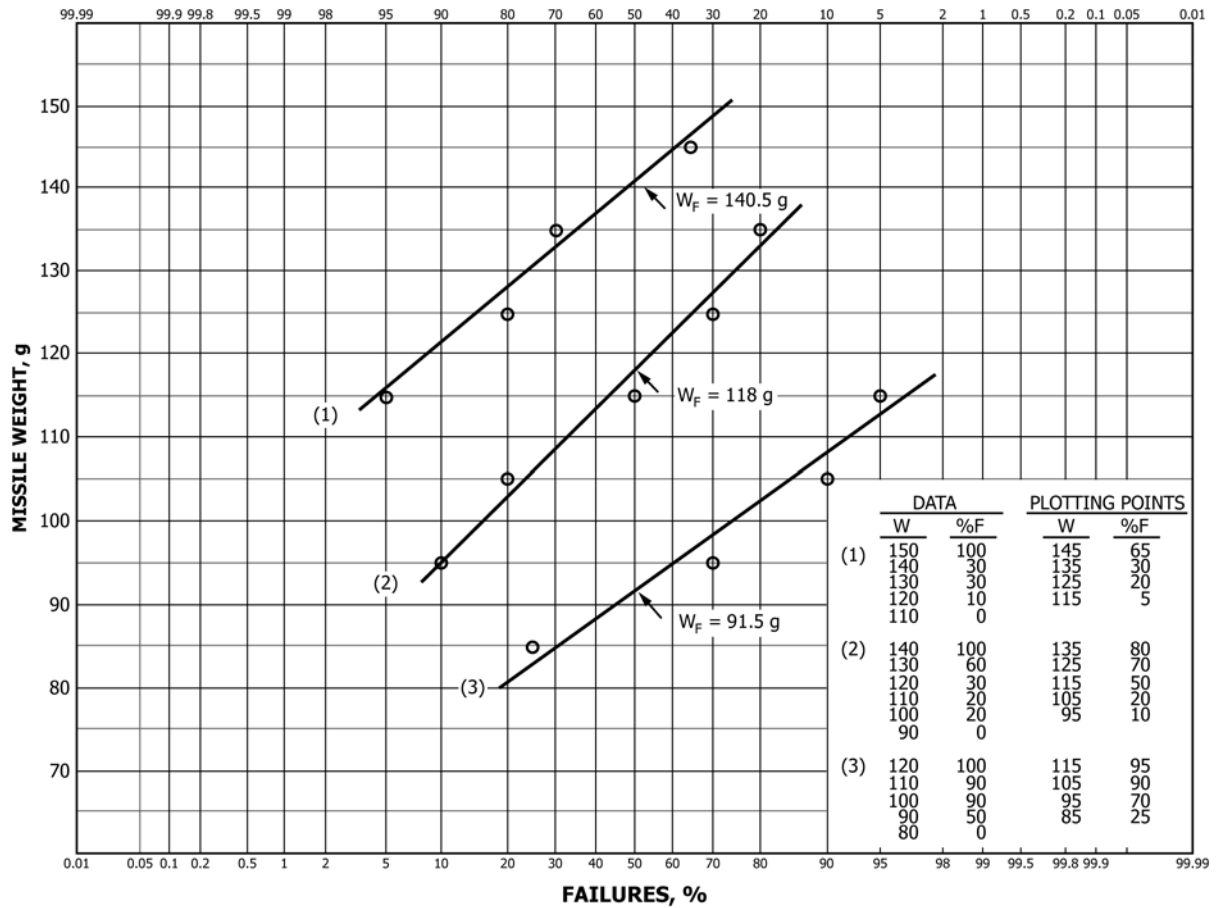

FIG. 3 Graphical Determination of Impact Failure Weight

approximate precision of this test method. Do not apply the data presented in Table 1 to acceptance or rejection of materials, as these data apply only to the materials tested in the round robin and are unlikely to be rigorously representative of other lots, formulations, conditions, materials, or laboratories. Users of this test method need to apply the principles outlined in Practice E691 to generate data specific to their materials and laboratory (or between specific laboratories). The principles of 15.2 through 15.2.3 would then be valid for such data.)

15.2 Concept of “r” and “R” in Table 1—If  $S_r$  and  $S_R$  have been calculated from a large enough body of data, and for test results that were averages from testing five specimens for each test result, then:

15.2.1 Repeatability—“r” is the interval representing the critical difference between two test results for the same material, obtained by the same operator using the same equipment on the same day in the same laboratory. Two test

results shall be judged not equivalent if they differ by more than the “r” value for that material.

15.2.2 Reproducibility—“R” is the interval representing the critical difference between two test results for the same material, obtained by different operators using different equipment in different laboratories, not necessarily on the same day. Two test results shall be judged not equivalent if they differ by more than the “R” value for that material.

15.2.3 Any judgement in accordance with 15.2.1 or 15.2.2 would have an approximate 95 % (0.95) probability of being correct.

15.3 There are no recognized standards by which to estimate bias of this test method.

## 16. Keywords

16.1 drop dart; impact; plastic film



**APPENDIX**

(Nonmandatory Information)

**X1. IMPACT VALUES BY FOUR TEST METHODS**

**TABLE X1.1 Impact Values by Four Test Methods**

Material <sup>A</sup>	D3420 Procedure A <sup>B</sup>	D3420 Procedure B <sup>C</sup>	D1709 (Method A)		D4272	
	J	J	g <i>D</i>	J <i>D</i>	ft · lb · f	J
PP, 1 mil	0.30	0.27			0.07 <sup>E</sup>	0.09 <sup>E</sup>
PP, 2 mil	0.95	0.65	75 <sup>C</sup>	0.49 <sup>F</sup>	5.17 <sup>E</sup>	7.01 <sup>E</sup>
LLDPE, 1 mil	0.52	0.41	47 <sup>G</sup>	0.30 <sup>G</sup>	0.36 <sup>H</sup>	0.49 <sup>H</sup>
LLDPE, 3.5 mil	1.43	0.97	309 <sup>I</sup>	2.00 <sup>I</sup>	2.46 <sup>H</sup>	3.34 <sup>H</sup>

<sup>A</sup>LLDPE (linear low density polyethylene).

<sup>B</sup>Four laboratories, two sets of data each.

<sup>C</sup>Eight laboratories, two sets of data each.

<sup>D</sup>Minimum weight of the tester was too heavy.

<sup>E</sup>One laboratory, one set of data.

<sup>F</sup>Three laboratories, one set of data each.

<sup>G</sup>Two laboratories, one set of data each.

<sup>H</sup>Two laboratories, one set of data each.

<sup>I</sup>Five laboratories, one set of data each.

**SUMMARY OF CHANGES**

Committee D20 has identified the location of selected changes to this standard since the last issue (D1709 - 16) that may impact the use of this standard. (May 1, 2016)

(1) Revised wording in 5.2.1 through 5.2.3.

Committee D20 has identified the location of selected changes to this standard since the last issue (D1709 - 15a) that may impact the use of this standard. (April 15, 2016)

(1) Revised the clamp inside diameter dimension in 5.1.2, 5.1.2.3, and 5.1.2.4.

Committee D20 has identified the location of selected changes to this standard since the last issue (D1709 - 15) that may impact the use of this standard. (May 15, 2015)

- |  |   |
|--|---|
| <p>(1) Revised 1.2.1, 1.2.2, and 5.1.3.</p> <p>(2) Conducted a five-year review, which resulted in numerous wording changes involving permissive language or need for clarification.</p> | <p>(3) Corrected steel tip sizing in 5.2, from 12.5 mm to 12.7 mm.</p> <p>(4) Adjusted other metric measurements to be equivalent to the English unit measurements.</p> |
|--|---|

Committee D20 has identified the location of selected changes to this standard since the last issue (D1709 - 09) that may impact the use of this standard. (January 1, 2015)

- |   |                                     |
|---|-------------------------------------|
| (1) Revised ISO equivalency statement (Note 3). | (2) Corrected decimal error in 5.2. |
|---|-------------------------------------|

*ASTM International takes no position respecting the validity of any patent rights asserted in connection with any item mentioned in this standard. Users of this standard are expressly advised that determination of the validity of any such patent rights, and the risk of infringement of such rights, are entirely their own responsibility.*

*This standard is subject to revision at any time by the responsible technical committee and must be reviewed every five years and if not revised, either reapproved or withdrawn. Your comments are invited either for revision of this standard or for additional standards and should be addressed to ASTM International Headquarters. Your comments will receive careful consideration at a meeting of the responsible technical committee, which you may attend. If you feel that your comments have not received a fair hearing you should make your views known to the ASTM Committee on Standards, at the address shown below.*

*This standard is copyrighted by ASTM International, 100 Barr Harbor Drive, PO Box C700, West Conshohocken, PA 19428-2959, United States. Individual reprints (single or multiple copies) of this standard may be obtained by contacting ASTM at the above address or at 610-832-9585 (phone), 610-832-9555 (fax), or [service@astm.org](mailto:service@astm.org) (e-mail); or through the ASTM website ([www.astm.org](http://www.astm.org)). Permission rights to photocopy the standard may also be secured from the Copyright Clearance Center, 222 Rosewood Drive, Danvers, MA 01923, Tel: (978) 646-2600; <http://www.copyright.com/>*