



Standard Practice for Making and Curing Soil-Cement Compression and Flexure Test Specimens in the Laboratory¹

This standard is issued under the fixed designation D1632; the number immediately following the designation indicates the year of original adoption or, in the case of revision, the year of last revision. A number in parentheses indicates the year of last reapproval. A superscript epsilon (ϵ) indicates an editorial change since the last revision or reapproval.

1. Scope*

1.1 This practice covers the procedure for making and curing compression and flexure test specimens of soil-cement in the laboratory under accurate control of quantities of materials and test conditions.

1.2 The values stated in SI units are to be regarded as the standard. The inch-pound equivalents are shown for information only.

1.3 *This practice offers a set of instructions for performing one or more specific operations. This document cannot replace education or experience and should be used in conjunction with professional judgment. Not all aspects of this practice may be applicable in all circumstances. This ASTM standard is not intended to represent or replace the standard of care by which the adequacy of a given professional service must be judged, nor should this document be applied without consideration of a project's many unique aspects. The word "Standard" in the title of this document means only that the document has been approved through the ASTM consensus process.*

1.4 *This standard may involve hazardous materials, operations, and equipment. This standard does not purport to address all of the safety concerns, if any, associated with its use. It is the responsibility of the user of this standard to establish appropriate safety and health practices and determine the applicability of regulatory limitations prior to use.*

2. Referenced Documents

2.1 ASTM Standards:²

C127 Test Method for Density, Relative Density (Specific Gravity), and Absorption of Coarse Aggregate

C617 Practice for Capping Cylindrical Concrete Specimens

¹ This practice is under the jurisdiction of ASTM Committee D18 on Soil and Rock and is the direct responsibility of Subcommittee D18.15 on Stabilization With Admixtures.

Current edition approved Nov. 1, 2007. Published December 2007. Originally approved in 1959. Last previous edition approved in 2006 as D1632 – 06. DOI: 10.1520/D1632-07.

² For referenced ASTM standards, visit the ASTM website, www.astm.org, or contact ASTM Customer Service at service@astm.org. For *Annual Book of ASTM Standards* volume information, refer to the standard's Document Summary page on the ASTM website.

- D558** Test Methods for Moisture-Density (Unit Weight) Relations of Soil-Cement Mixtures
- D559** Test Methods for Wetting and Drying Compacted Soil-Cement Mixtures (Withdrawn 2012)³
- D560** Test Methods for Freezing and Thawing Compacted Soil-Cement Mixtures (Withdrawn 2012)³
- D653** Terminology Relating to Soil, Rock, and Contained Fluids
- D1633** Test Methods for Compressive Strength of Molded Soil-Cement Cylinders
- D1634** Test Method for Compressive Strength of Soil-Cement Using Portions of Beams Broken in Flexure (Modified Cube Method)
- D1635** Test Method for Flexural Strength of Soil-Cement Using Simple Beam with Third-Point Loading
- D3740** Practice for Minimum Requirements for Agencies Engaged in Testing and/or Inspection of Soil and Rock as Used in Engineering Design and Construction
- D4753** Guide for Evaluating, Selecting, and Specifying Balances and Standard Masses for Use in Soil, Rock, and Construction Materials Testing
- D6026** Practice for Using Significant Digits in Geotechnical Data
- E11** Specification for Woven Wire Test Sieve Cloth and Test Sieves

3. Terminology

3.1 For common definitions of terms used in this standard refer to Terminology **D653**.

4. Significance and Use

4.1 This practice is used to prepare soil-cement specimens for compressive and flexural strength testing in accordance with Method B of Test Method **D1633**, Test Method **D1634**, and Test Method **D1635**.

4.2 This practice does not apply to soil-cement specimens prepared in commonly available molds, which are 4.0 in. (101.6 mm) in diameter and 4.584 in. (116.4 mm) in height. For these size specimens, Methods **D559** or Methods **D560**

³ The last approved version of this historical standard is referenced on www.astm.org.

*A Summary of Changes section appears at the end of this standard

should be used for sample preparation. Compressive strength testing should be in accordance with Method A of Test Method D1633.

4.3 This practice offers a set of instructions for performing one or more specific operations. This document cannot replace education or experience and should be used in conjunction with professional judgment. Not all aspects of this practice may be applicable in all circumstances. This ASTM standard is not intended to represent or replace the standard of care by which the adequacy of a given professional service must be judged, nor should this document be applied without consideration of a project's many unique aspects. The word "standard" in the title of this document means only that the document has been approved through the ASTM consensus process.

NOTE 1—The quality of the result produced by this standard is dependent on the competence of the personnel performing it, and the suitability of the equipment and facilities used. Agencies that meet the criteria of Practice D3740 are generally considered capable of competent and objective testing/sampling/inspection/etc. Users of this standard are cautioned that compliance with Practice D3740 does not in itself assure reliable results. Reliable results depend on many factors; Practice D3740 provides a means of evaluating some of those factors.

5. Apparatus

5.1 Compression Test Specimen Molds —Molds (Fig. 1)

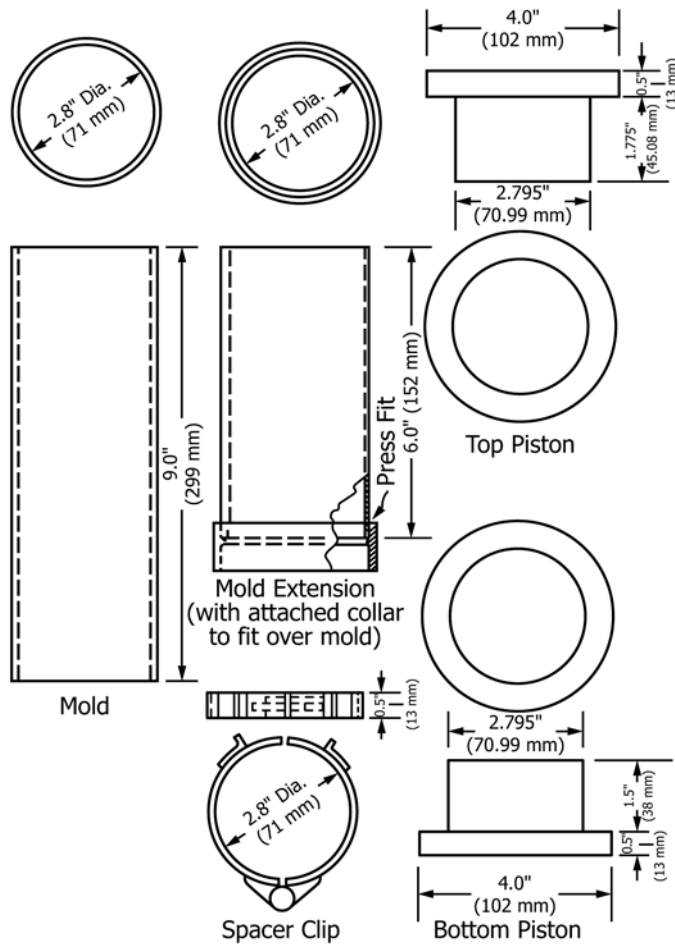

FIG. 1 Soil-Cement Cylinder Mold

having an inside diameter of 71 ± 0.25 mm (2.8 ± 0.01 in.) and a height of 229 mm (9 in.) for molding test specimens 71 mm (2.8 in.) in diameter and 142 mm (5.6 in.) high; machined steel top and bottom pistons having a diameter 0.13 mm (0.005 in.) less than the mold; a 152-mm (6-in.) long mold extension; and a spacer clip. At least two aluminum separating disks 1.54 mm ($1/16$ in.) thick by 70.6 mm (2.78 in.) in diameter shall be provided.

NOTE 2—Satisfactory molds may be made from cold-drawn, seamless steel tubing having a Rockwell hardness of approximately 85 HRB or from steel pipe machined on the inside. The 71 by 142-mm (2.8 by 5.6-in.) specimens fit many triaxial compression machines in service, and thus may be used for triaxial as well as unconfined compression tests.

5.2 Flexure Test Specimen Molds—Molds having inside dimensions of 76.2 by 76.2 by 285.8 mm (3 by 3 by 11¼ in.) (see Fig. 2 and Fig. 3) for molding specimens of the same size. The molds shall be so designed that the specimen will be molded with its longitudinal axis in a horizontal position. The parts of the molds shall be tight-fitting and positively held together. The sides of the molds shall be sufficiently rigid to prevent spreading or warping, and shall be made of metal having a hardness not less than 85 HRB. The interior faces of the molds shall be plane surfaces with a permissible variation, in any 76.2-mm (3-in.) line on a surface, of 0.051 mm (0.002 in.) for new molds and 0.076 mm (0.003 in.) for molds in use. The distance between opposite sides shall be 76.20 ± 0.25 mm (3 ± 0.01 in.) for new molds, and 76.20 ± 0.38 mm (3 ± 0.015 in.) for molds in use. The height of the molds shall be 76.20 mm (3 in.) with permissible variations of -0.25 mm (-0.01 in.) and $+0.13$ mm ($+0.005$ in.) for both new molds and for molds in use. Four 9.52-mm ($3/8$ -in.) spacer bars and top and bottom machined steel plates shall be provided. The plates shall fit the mold with a 0.13-mm (0.005-in.) clearance on all sides.

5.3 Sieves—50-mm (2-in.), 19.0-mm ($3/4$ -in.), 4.75-mm (No. 4) and 1.18-mm (No. 16) sieves conforming to the requirements of Specification E11.

5.4 Balances—A balance or scale of 12-kg (25-lb) capacity, sensitive to 0.0045 kg (0.01 lb) and a balance of 1000-g capacity, sensitive to 0.1 g, both meeting the requirements of Specification D4753.

5.5 Drying Oven—A thermostatically controlled drying oven capable of maintaining a temperature of $110 \pm 5^\circ\text{C}$ ($230 \pm 9^\circ\text{F}$) for drying moisture samples.

5.6 Compression Testing Machine or Compression Frame, having a capacity of approximately 267 kN (60 000 lbf) for compacting flexural test specimens and for optional use in compacting compression test specimens.

5.7 Dropping-Weight Compacting Machine—A controlled dropping-weight device of 6.8 kg (15 lb) for striking the top piston, for optional use in compacting compression test specimens (see Fig. 4 and Fig. 5). When this equipment is used, the top piston listed in 5.1 is made the foot of the compacting device.

5.8 Compression Specimen Extruder, consisting of a piston, jack, and frame for extruding specimens from the mold.

5.9 Miscellaneous Equipment—Tools such as trowel, spatula, pan, and the like, or a suitable mechanical device for

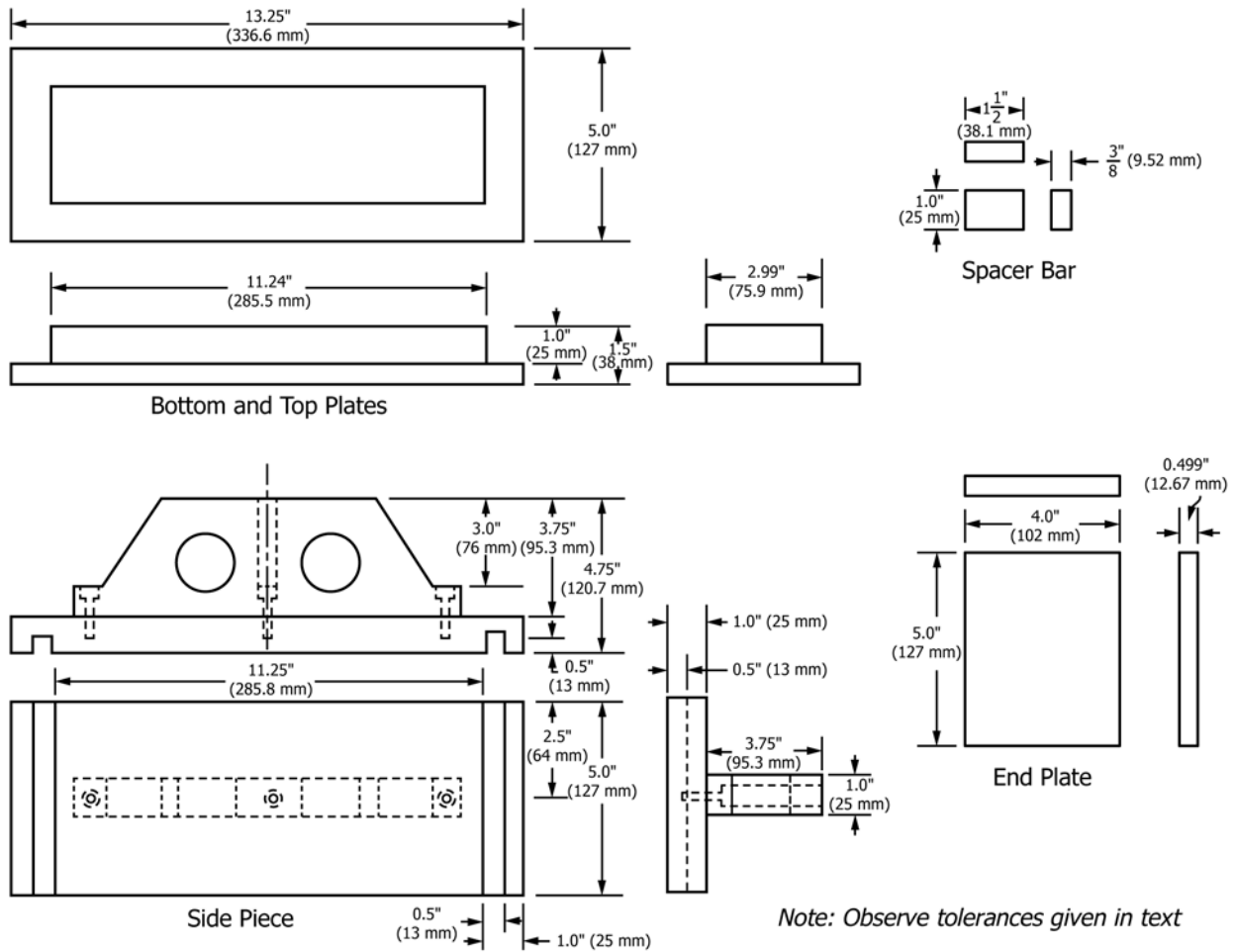

FIG. 2 Mold for Soil-Cement Beam for Flexure Test

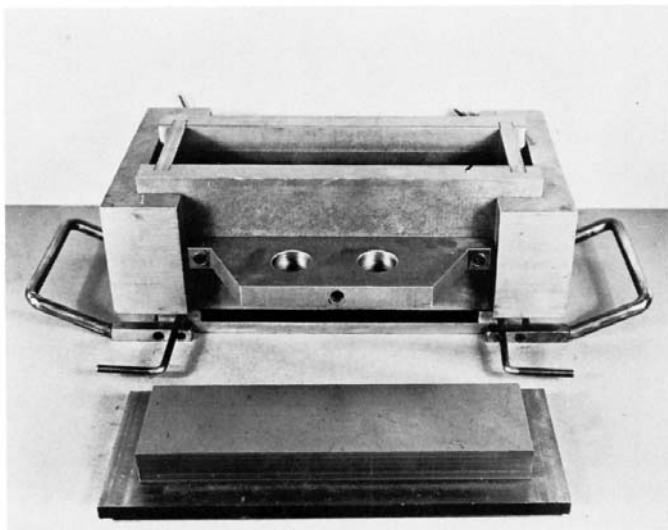

FIG. 3 Heavy Steel Mold and Top Plate for Making 3 by 3 by 1 1/4-in. (76.2 by 76.2 by 285.8-mm) Flexure Test Beam

thoroughly mixing the sample of soil-cement with water; graduated cylinder for measuring water, moisture sample cans, and the like.

5.10 *Tamping Rod*—A square-end cut, 12.7-mm (1/2-in.) diameter, smooth steel rod approximately 510 mm (20 in.) in length.

5.11 *Moist Room or Cabinet*—A moist room or cabinet capable of maintaining a temperature of $23.0 \pm 1.7^\circ\text{C}$ ($73.4 \pm 3^\circ\text{F}$) and a relative humidity of not less than 96 % for moist curing specimens.

6. Preparation of Materials

6.1 Bring materials to room temperature (preferably 18 to 24°C (65 to 75°F)) before beginning the tests.

6.2 Store cement in a dry place, in moisture-proof containers, preferably made of metal. Thoroughly mix the cement in order that the sample may be uniform throughout the tests. Pass it through a 1.18-mm (No. 16) sieve and reject all lumps.

6.3 The mixing water shall be free of acids, alkalis, and oils, and in general suitable for drinking.

6.4 Dry the soil sample, if damp when received from the field, until it becomes friable under a trowel. Drying may be in air or by use of drying apparatus such that the temperature of the sample does not exceed 60°C (140°F). Thoroughly break up the aggregations in such a manner as to avoid reducing the natural size of individual particles.

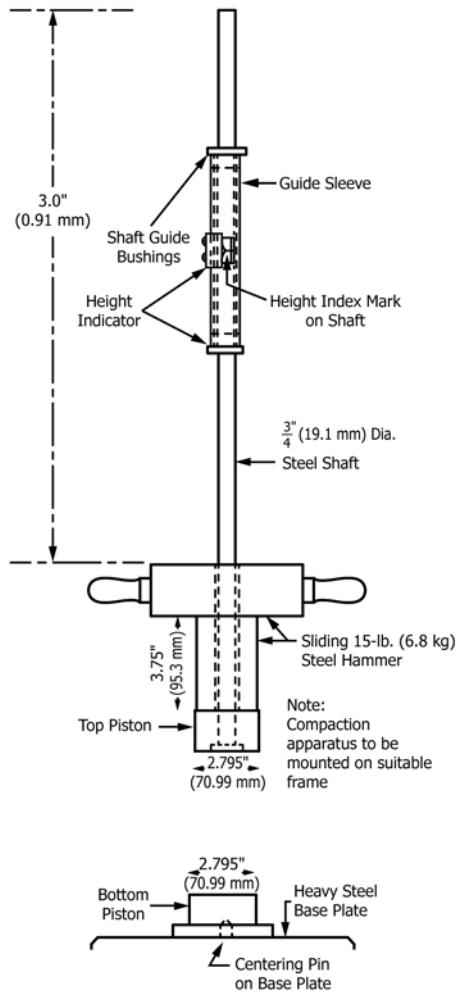

FIG. 4 Schematic Drawing of a Suitable Compacting Device

6.5 Sieve an adequate quantity of representative pulverized soil on the 50-mm (2-in.), 19.0-mm (3/4-in.), and 4.75-mm (No. 4) sieves. Discard any aggregate retained on the 50-mm (2-in.) sieve. Remove aggregate passing the 50-mm (2-in.) sieve and retained on the 19.0-mm (3/4-in.) sieve, and replace it with an equal mass of aggregate passing the 19.0-mm (3/4-in.) sieve and retained on the 4.75-mm (No. 4) sieve. Obtain aggregate for replacement from the original sample.

NOTE 3—This practice for making soil-cement specimens for compression and flexure tests is used primarily with soil materials having not more than 35 % aggregate retained on the 4.75-mm (No. 4) sieve and not more than 85 % retained on the 425- μ m (No. 40) sieve.

6.6 Soak the aggregate passing the 19.0-mm (3/4-in.) sieve and retained on the 4.75-mm (No. 4) sieve in water for 24 h, remove, and surface dry. Determine the absorption properties in accordance with Test Method C127.

6.7 Take a 100-g sample of the soil passing the 4.75-mm (No. 4) sieve and dry it in the drying oven to constant mass, and determine the water content of the sample to permit calculation of the quantity of water that shall be added to the soil-cement mixture to bring it to the proper water content for molding specimens.

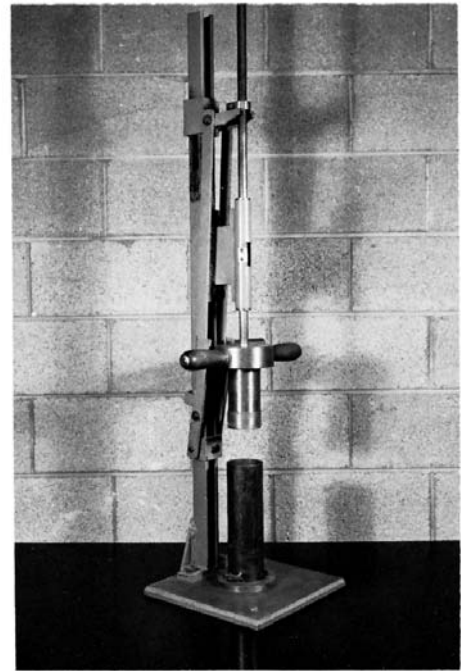

FIG. 5 Compacting Device Suitable for Making 2.8 by 5.6-in. (71 by 142 mm) Compression Test Cylinder

6.8 Take a representative sample of sufficient size to make one flexure test specimen or three compression test specimens of the soil passing the 4.75-mm (No. 4) sieve and also of the fractions passing the 19.0-mm (3/4-in.) sieve and retained on the 4.75-mm (No. 4) sieve, prepared as described in 6.4, 6.5, and 6.6.

7. Determining the Mass of Materials

7.1 Determine the mass to the nearest 5 g (0.01 lb) the designed quantities of soil passing the 4.75-mm (No. 4) sieve and aggregate passing the 19.0-mm (3/4-in.) sieve and retained on the 4.75-mm (No. 4) sieve. Determine the mass to the nearest 1 g of the designed quantity of cement and measure the designed quantity of water to the nearest 1 mL.

NOTE 4—The designed quantities of soil, cement, and water are usually based on results obtained from ASTM tests. The “optimum” water content of the mixture and the “maximum” unit weight to which the specimens are compacted are determined by Test Methods D558. The quantity of cement is usually sufficient to produce soil-cement of a quality suitable for road and runway base construction. This cement quantity is indicated by criteria established for interpreting the results obtained from Methods D559 and Methods D560.

8. Mixing Materials

8.1 *General*—Mix soil-cement either by hand or in a suitable laboratory mixer in batches of such size as to leave about 10% excess after molding test specimens. Protect this material against loss of water, determine the mass of a representative part of it and dry it in the drying oven to constant mass to determine the actual water content of the soil-cement mixture. When the soil-cement mixture contains aggregate retained on the 4.75-mm (No. 4) sieve, the sample for water content determination shall have a mass of at least 500 g and its mass

shall be determined to the nearest gram. If the mixture does not contain aggregate retained on the 4.75-mm (No. 4) sieve, the sample shall have a mass of at least 100 g and its mass shall be determined to the nearest 0.1 g. The operation of mixing and compacting compression and flexure test specimens shall be continuous and the elapsed time between the addition of water and final compaction shall not exceed 30 min.

8.2 *Hand Mixing*—Mix the batch in a clean, damp, metal pan or on top of a steel table, with a blunt bricklayer's trowel, using the following procedure:

8.2.1 Mix the cement and minus 4.75-mm (No. 4) soil until they are thoroughly blended.

8.2.2 Add water and mix the mass until it is thoroughly blended.

8.2.3 Add the saturated surface-dry coarse aggregate and mix the entire batch until the coarse aggregate is uniformly distributed throughout the batch.

8.3 *Machine Mixing*—Follow the sequence specified for hand mixing. To eliminate segregation, deposit machine-mixed soil-cement in a clean, damp, metal pan and remix with the trowel.

COMPRESSION TEST SPECIMENS

9. Size of Specimens

9.1 Compression test specimens shall be cylinders with a length equal to twice the diameter. This method provides for specimens 71 mm (2.8 in.) in diameter by 142 mm (5.6 in.) in length, but the same procedure may be used for molding larger or smaller specimens.

10. Molding Specimens

10.1 Lightly coat the mold and the two separating disks with commercial form oil. Hold the cylinder mold in place with the spacer clip over the bottom piston so that the latter extends about 25 mm (1 in.) into the cylinder.

10.2 Place a separating disk on top of the bottom piston and place the extension sleeve on top of the mold. Place in the mold a predetermined mass of the uniformly mixed soil-cement to provide a specimen of the designed unit weight when 142 mm (5.6 in.) high. When the soil-cement contains aggregate retained on the 4.75-mm (No. 4) sieve, carefully spade the mix around the mold sides with a thin spatula. Then compact the soil-cement initially from the bottom up by steadily and firmly forcing (with little impact) a square-end cut 12.7-mm ($\frac{1}{2}$ -in.) diameter smooth steel rod repeatedly through the mixture from the top down to the point of refusal, distributing the roddings uniformly over the cross-section of the mold. Perform the operation carefully so as not to leave holes in clayey soil-cement mixtures. Repeat the process until the mass is packed out to a height of approximately 150 mm (6 in.).

10.3 Remove the extension sleeve and place a separating disk on the surface of the soil-cement. Remove the spacer clip supporting the mold on the bottom piston. Put the top piston in place and apply either a static load by the compression machine or a dynamic load by the compacting device until the specimen is 142 mm (5.6 in.) high.

10.4 Remove the pistons and separating disks from the mold assembly, but leave the specimen in the mold.

11. Curing Specimens

11.1 Cure the specimens in the molds in the moist room for 12 h, or longer if required, to permit subsequent removal from the molds using the sample extruder. Return the specimens to the moist room, but protect from dripping water for the specified moist curing period. Generally the specimens will be tested in the moist condition directly after removal from the moist room.

NOTE 5—Other conditioning procedures, such as soaking in water, air drying or oven drying, alternate wetting and drying, or alternate freezing and thawing, may be specified after an initial moist curing period. Curing and conditioning procedures shall be given in detail in the report.

12. Capping Specimens

12.1 Before testing, cap the ends of all compression specimens that are not plane within 0.05 mm (0.002 in.). Capped surfaces shall meet this same tolerance and shall be at right angles to the axis of the specimen.

12.2 Cap the specimens with gypsum plaster or sulfur mortar. The caps shall be as thin as practical and shall be aged sufficiently so that they will not flow or fracture when the specimen is tested (suggested time 3 h at 23°C (73°F)). During this period maintain the specimens at constant water content.

FLEXURE TEST SPECIMENS

13. Size of Specimen

13.1 Flexure test specimens shall be rectangular beams with a length as tested at least 51 mm (2 in.) greater than three times the depth. This procedure provides for beams 76.2 by 76.2 by 285.8 mm (3 by 3 by 11¼ in.), but the same procedures may be used for molding smaller or larger specimens.

14. Molding Specimens

14.1 Form the test specimens with the longitudinal axis horizontal. Lightly oil the mold parts and assemble with the sides and ends separated from the base plate by the 9.53-mm ($\frac{3}{8}$ -in.) spacer bars, one placed at each corner of the mold.

14.2 Divide into three equal batches a predetermined mass of uniformly mixed soil-cement to make a beam of the designed unit weight. Place one batch of the material in the mold and level by hand. When the soil-cement contains aggregate retained on the 4.75-mm (No. 4) sieve, carefully spade the mix around the sides of the mold with a thin spatula. Compact the soil-cement initially from the bottom up by steadily and firmly, forcing (with little impact) a square-end cut 12.7-mm ($\frac{1}{2}$ -in.) diameter smooth steel rod repeatedly through the mixture from the top down to the point of refusal. Approximately 90 roddings distributed uniformly over the cross section of the mold are required; take care so as not to leave holes in clayey soil-cement mixtures. Level this layer of compacted soil-cement by hand and place and compact layers two and three in an identical manner. The specimen at this time shall be approximately 95 mm ($3\frac{3}{4}$ in.) high.

14.3 Place the top plate of the mold in position and remove the spacer bars. Obtain final compaction with a static load applied by the compression machine or compression frame until the designed height of 76 mm (3.0 in.) is reached.

14.4 Immediately after compaction, carefully dismantle the mold and remove the specimen onto a smooth, rigid, wood or sheet metal pallet.

NOTE 6—A suggested method for removing the specimen from the mold is to remove first the top and then the sides and end plates of the mold. The specimen is then resting on the bottom plate of the mold. The flat face of a carrying pallet is then placed against one side of the specimen and then the bottom mold plate, the specimen, and the pallet are rotated 90° so that the specimen rests on its side on the pallet. The bottom mold plate is then carefully removed.

15. Curing Specimens

15.1 Cure the specimens on pallets in the moist room and protect from free water for the specified moist curing period. Generally the specimen will be tested in the moist condition directly after removal from the moist room (see Note 5).

16. Capping Specimens

16.1 Before testing, cap areas, on opposite *sides* of the specimens as molded, that will come in contact with the load-applying block and supports and that are not plane within 0.05 mm (0.002 in.). Capped surfaces shall meet this same tolerance and shall be parallel to the horizontal axis of the specimen.

NOTE 7—Specimens are tested on their sides, with the original top and bottom surfaces as molded perpendicular to the testing machine bed. Specimens made in molds meeting the specifications in 4.2 generally will not require capping.

16.2 If capping is necessary, cap specimens with gypsum plaster or sulfur mortar. The caps shall be as thin as practical and shall be aged sufficiently so that they will not flow or fracture when the specimen is tested (suggested time 3 h at 23°C (73°F)). During this period maintain the specimens at constant water content.

REPORT

17. Report

17.1 The report shall include the following:

17.1.1 Gradation of soil as received and as used in making specimens,

17.1.2 Specimen identification number,

17.1.3 Designed water content,

17.1.4 Designed oven-dry unit weight,

17.1.5 Designed cement content,

17.1.6 Actual water content,

17.1.7 Actual oven-dry unit weight,

17.1.8 Actual cement content, and

17.1.9 Details of curing and conditioning periods.

17.2 Significant digits shall be in accordance with Practice D6026.

18. Precision and Bias

18.1 This practice describes procedures for making and curing test specimens. Since there are no test values determined, a statement on precision and bias of the method is not applicable.

19. Keywords

19.1 flexural strength; soil-cement; soil stabilization; unconfined compressive strength

SUMMARY OF CHANGES

Committee D18 has identified the location of selected changes to this standard since the last issue (D1632 – 06) that may impact the use of this standard. (Approved November 1, 2007.)

(1) Section 1.2 was added regarding units.

(2) C617, D653, D3740 were added to Section 2.1.

(3) Section 3 on Terminology was added.

(4) Section 4.3 was added.

(5) Note 1 regarding Practice D3740 was added.

(6) Section 5.9 was revised to read “graduated cylinder.”

(7) Sulfur Mortar was added to Sections 12.2 and 16.2.

(8) Fig. 4 description was changed to keep apparatus description consistent with Fig. 5 and maintain the idea that little impact is suppose to be used in molding specimens in section 10.2 and 14.2.

(9) SI units were changed to standard and inch-pound equivalents to informational in text.

ASTM International takes no position respecting the validity of any patent rights asserted in connection with any item mentioned in this standard. Users of this standard are expressly advised that determination of the validity of any such patent rights, and the risk of infringement of such rights, are entirely their own responsibility.

This standard is subject to revision at any time by the responsible technical committee and must be reviewed every five years and if not revised, either reapproved or withdrawn. Your comments are invited either for revision of this standard or for additional standards and should be addressed to ASTM International Headquarters. Your comments will receive careful consideration at a meeting of the responsible technical committee, which you may attend. If you feel that your comments have not received a fair hearing you should make your views known to the ASTM Committee on Standards, at the address shown below.

This standard is copyrighted by ASTM International, 100 Barr Harbor Drive, PO Box C700, West Conshohocken, PA 19428-2959, United States. Individual reprints (single or multiple copies) of this standard may be obtained by contacting ASTM at the above address or at 610-832-9585 (phone), 610-832-9555 (fax), or service@astm.org (e-mail); or through the ASTM website (www.astm.org). Permission rights to photocopy the standard may also be secured from the Copyright Clearance Center, 222 Rosewood Drive, Danvers, MA 01923, Tel: (978) 646-2600; <http://www.copyright.com/>