



NOTICE OF
ADOPTION

M

ADOPTION NOTICE 1
9 February 1990 for
ASTM D 1559-89
October 18, 1989
SUPERSEDING
ASTM D 1559-82
8 April 1983

ASTM D 1559-89 was adopted on 9 February 1990 and is approved for use by the Department of Defense (DoD). ASTM has furnished the clearance required by existing regulations. Copies of this document are stocked by the DoD Single Stock Point, Military Specifications and Standards, 700 Robbins Avenue, Bldg. 4D, Philadelphia, PA 19111-5094, for issue to DoD activities only. All other requestors must obtain documents from:

ASTM
1916 Race Street
Philadelphia, PA 19103

Title of Document: Standard Test Method for Resistance to Plastic Flow of Bituminous Mixtures Using Marshall Apparatus¹

Date of Specific Issue Adopted: October 18, 1989

Releasing Non-Government Standards Body: ASTM

Custodians:
Navy - YD
Air Force - 99

Military Coordinating Activity:
Navy - YD
(Project 5610-0658)

Review Activity:
Navy - MC

User Activity:
Army - CE

FSC 5610

DISTRIBUTION STATEMENT A. Approved for public release; distribution is unlimited.



Designation: D 1559 - 89

AMERICAN SOCIETY FOR TESTING AND MATERIALS
1916 Race St., Philadelphia, Pa. 19103
Reprinted from the Annual Book of ASTM Standards, Copyright ASTM
If not listed in the current combined index, will appear in the next edition.

Standard Test Method for Resistance to Plastic Flow of Bituminous Mixtures Using Marshall Apparatus¹

This standard is issued under the fixed designation D 1559; the number immediately following the designation indicates the year of original adoption or, in the case of revision, the year of last revision. A number in parentheses indicates the year of last reappraisal. A superscript epsilon (ϵ) indicates an editorial change since the last revision or reappraisal.

This standard has been approved for use by agencies of the Department of Defense. Consult the DoD Index of Specifications and Standards for the specific year of issue which has been adopted by the Department of Defense.

1. Scope

1.1 This test method covers the measurement of the resistance to plastic flow of cylindrical specimens of bituminous paving mixture loaded on the lateral surface by means of the Marshall apparatus. This test method is for use with mixtures containing asphalt cement, asphalt cut-back or tar, and aggregate up to 1-in. (25.4-mm) maximum size.

1.2 *This standard may involve hazardous materials, operations, and equipment. This standard does not purport to address all of the safety problems associated with its use. It is the responsibility of the user of this standard to establish appropriate safety and health practices and determine the applicability of regulatory limitations prior to use.*

2. Significance and Use

2.1 This test method is used in the laboratory mix design of bituminous mixtures. Specimens are prepared in accordance with the method and tested for maximum load and flow. Density and voids properties may also be determined on specimens prepared in accordance with the test method. The testing section of this method can also be used to obtain maximum load and flow for bituminous paving specimens cored from pavements or prepared by other methods. These results may differ from values obtained on specimens prepared by this test method.

3. Apparatus

3.1 *Specimen Mold Assembly*—Mold cylinders 4 in. (101.6 mm) in diameter by 3 in. (76.2 mm) in height, base plates, and extension collars shall conform to the details shown in Fig. 1. Three mold cylinders are recommended.

3.2 *Specimen Extractor*, steel, in the form of a disk with a diameter not less than 3.95 in. (100 mm) and ½ in. (13 mm) thick for extracting the compacted specimen from the specimen mold with the use of the mold collar. A suitable bar is required to transfer the load from the ring dynamometer adapter to the extension collar while extracting the specimen.

3.3 *Compaction Hammer*—The compaction hammer (Fig. 2) shall have a flat, circular tamping face and a 10-lb (4536-g) sliding weight with a free fall of 18 in. (457.2 mm).

Two compaction hammers are recommended.

NOTE 1—The compaction hammer may be equipped with a finger safety guard as shown in Fig. 2.

3.4 *Compaction Pedestal*—The compaction pedestal shall consist of an 8 by 8 by 18-in. (203.2 by 203.2 by 457.2-mm) wooden post capped with a 12 by 12 by 1-in. (304.8 by 304.8 by 25.4-mm) steel plate. The wooden post shall be oak, pine, or other wood having an average dry weight of 42 to 48 lb/ft³ (0.67 to 0.77 g/cm³). The wooden post shall be secured by four angle brackets to a solid concrete slab. The steel cap shall be firmly fastened to the post. The pedestal assembly shall be installed so that the post is plumb and the cap is level.

3.5 *Specimen Mold Holder*, mounted on the compaction pedestal so as to center the compaction mold over the center of the post. It shall hold the compaction mold, collar, and base plate securely in position during compaction of the specimen.

3.6 *Breaking Head*—The breaking head (Fig. 3) shall consist of upper and lower cylindrical segments or test heads having an inside radius of curvature of 2 in. (50.8 mm) accurately machined. The lower segment shall be mounted on a base having two perpendicular guide rods or posts extending upward. Guide sleeves in the upper segment shall be in such a position as to direct the two segments together without appreciable binding or loose motion on the guide rods.

3.7 *Loading Jack*—The loading jack (Fig. 4) shall consist of a screw jack mounted in a testing frame and shall produce a uniform vertical movement of 2 in. (50.8 mm)/min. An electric motor may be attached to the jacking mechanism.

NOTE 2—Instead of the loading jack, a mechanical or hydraulic testing machine may be used provided the rate of movement can be maintained at 2 in. (50.8 mm)/min while the load is applied.

3.8 *Ring Dynamometer Assembly*—One ring dynamometer (Fig. 4) of 5000-lb (2267-kg) capacity and sensitivity of 10 lb (4.536 kg) up to 1000 lb (453.6 kg) and 25 lb (11.340 kg) between 1000 and 5000 lb (453.6 and 2267 kg) shall be equipped with a micrometer dial. The micrometer dial shall be graduated in 0.0001 in. (0.0025 mm). Upper and lower ring dynamometer attachments are required for fastening the ring dynamometer to the testing frame and transmitting the load to the breaking head.

NOTE 3—Instead of the ring dynamometer assembly, any suitable load-measuring device may be used provided the capacity and sensitivity meet the above requirements.

¹ This test method is under the jurisdiction of ASTM Committee D-4 on Road and Paving Materials and is the direct responsibility of Subcommittee D04.20 on Mechanical Tests of Bituminous Mixes.

Current edition approved Oct. 18, 1989. Published December 1989. Originally published as D 1559 - 58. Last previous edition D 1559 - 82.

D 1559

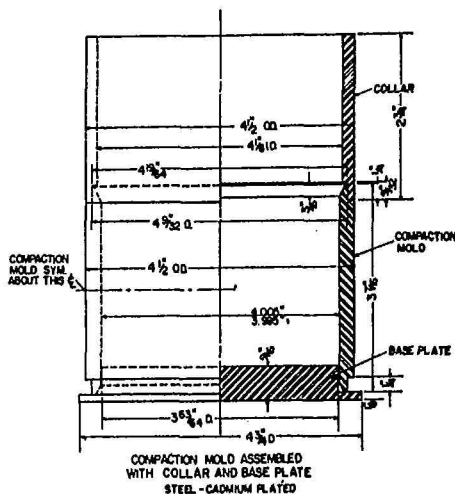

Table of Equivalents for Figs. 1 and 3

Inch-Pound Units, in.	Metric Equivalents, mm	Inch-Pound Units, in.	Metric Equivalents, mm	Inch-Pound Units, in.	Metric Equivalents, mm	Inch-Pound Units, in.	Metric Equivalents, mm
0.005	0.11	1 1/16	17.5	2 9/16	58.7	4 1/8	104.8
1/32	0.8	3/8	19.0	2 1/2	63.5	4 9/32	108.7
1/16	1.6	7/8	22.2	2 3/4	69.8	4 19/64	109.1
1/8	3.2	1 5/16	23.8	2 7/8	73.0	4 1/2	114.3
3/16	4.8	1	25.4	3	76.2	4 5/8	117.5
1/4	6.4	1 1/8	28.6	3 1/4	82.6	4 3/4	120.6
5/32	7.1	1 1/4	31.8	3 7/16	87.3	5 1/16	128.6
3/8	9.5	1 3/8	34.9	3 7/8	98.4	5 1/8	130.2
0.496	12.6	1 1/2	38.1	3 63/64	101.2	5 3/4	146.0
0.499	12.67	1 5/8	41.3	3.990	101.35	6	152.4
1/2	12.7	1 3/4	44.4	3.995	101.47	6 1/4	158.8
9/16	14.3	2	50.8	4	101.6	7 5/8	193.7
5/8	15.9	2 1/4	57.2	4.005	101.73	27	685.8

FIG. 1 Compaction Mold

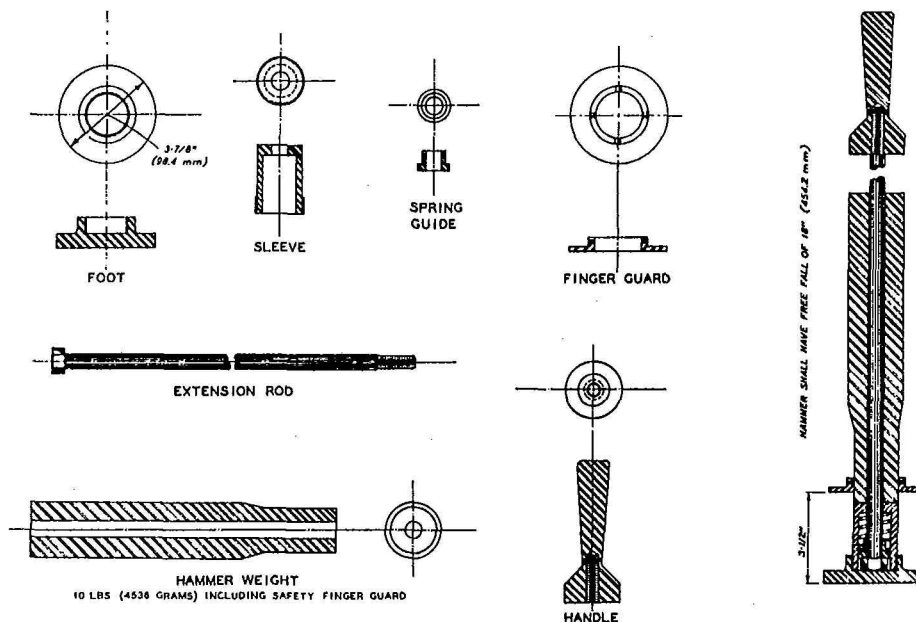
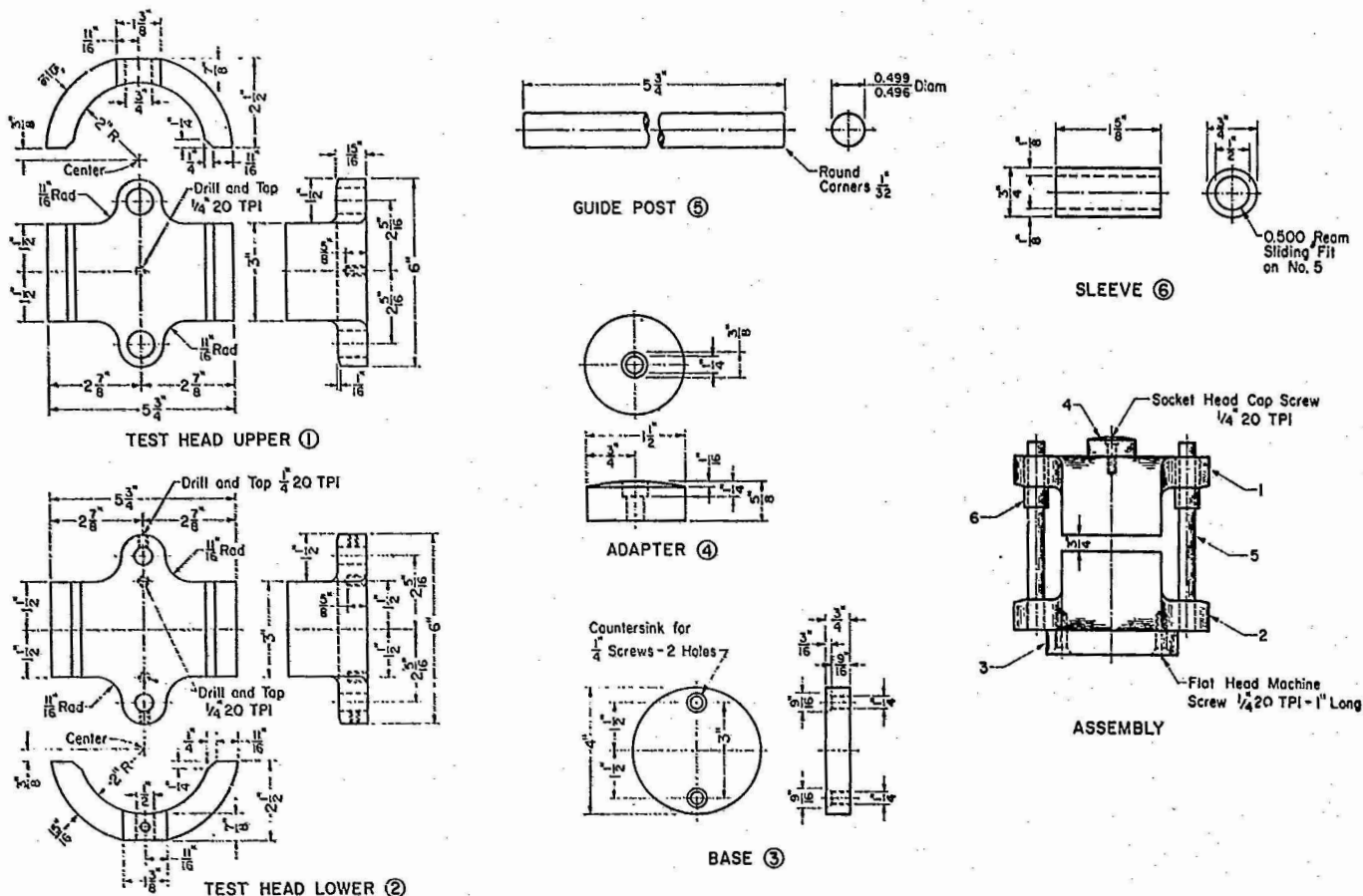

FIG. 2 Compaction Hammer

3.9 *Flowmeter*—The flowmeter shall consist of a guide sleeve and a gage. The activating pin of the gage shall slide inside the guide sleeve with a slight amount of frictional

resistance. The guide sleeve shall slide freely over the guide rod of the breaking head. The flowmeter gage shall be adjusted to zero when placed in position on the breaking

ASTM D 1559



(Table of Equivalents same as for Fig. 1.)

FIG. 3 Breaking Head

head when each individual test specimen is inserted between the breaking head segments. Graduations of the flowmeter gage shall be in 0.01-in. (0.25-mm) divisions.

NOTE 4—Instead of the flowmeter, a micrometer dial or stress-strain recorder graduated in 0.001 in. (0.025 mm) may be used to measure flow.

3.10 *Ovens or Hot Plates*—Ovens or hot plates shall be provided for heating aggregates, bituminous material, specimen molds, compaction hammers, and other equipment to the required mixing and molding temperatures. It is recommended that the heating units be thermostatically controlled so as to maintain the required temperature within 5°F (2.8°C). Suitable shields, baffle plates or sand baths shall be used on the surfaces of the hot plates to minimize localized overheating.

3.11 *Mixing Apparatus*—Mechanical mixing is recommended. Any type of mechanical mixer may be used provided it can be maintained at the required mixing temperature and will provide a well-coated, homogeneous mixture of the required amount in the allowable time, and further provided that essentially all of the batch can be recovered. A metal pan or bowl of sufficient capacity and hand mixing may also be used.

3.12 *Water Bath*—The water bath shall be at least 6 in. (152.4 mm) deep and shall be thermostatically controlled so as to maintain the bath at 140 ± 1.8°F (60 ± 1.0°C) or 100 ±

1.8°F (37.8 ± 1°C). The tank shall have a perforated false bottom or be equipped with a shelf for supporting specimens 2 in. (50.8 mm) above the bottom of the bath.

3.13 *Air Bath*—The air bath for asphalt cut-back mixtures shall be thermostatically controlled and shall maintain the air temperature at 77°F ± 1.8°F (25 ± 1.0°C).

3.14 *Miscellaneous Equipment:*

3.14.1 *Containers* for heating aggregates, flat-bottom metal pans or other suitable containers.

3.14.2 *Containers* for heating bituminous material, either gill-type tins, beakers, pouring pots, or saucepans may be used.

3.14.3 *Mixing Tool*, either a steel trowel (garden type) or spatula, for spading and hand mixing.

3.14.4 *Thermometers* for determining temperatures of aggregates, bitumen, and bituminous mixtures. Armored-glass or dial-type thermometers with metal stems are recommended. A range from 50 to 400°F (9.9 to 204°C), with sensitivity of 5°F (2.8°C) is required.

3.14.5 *Thermometers* for water and air baths with a range from 68 to 158°F (20 to 70°C) sensitive to 0.4°F (0.2°C).

3.14.6 *Balance*, 2-kg capacity, sensitive to 0.1 g, for weighing molded specimens.

3.14.7 *Balance*, 5-kg capacity, sensitive to 1.0 g, for batching mixtures.

3.14.8 *Gloves* for handling hot equipment.

 D 1559

FIG. 4 Compression Testing Machine

3.14.9 *Rubber Gloves* for removing specimens from water bath.

3.14.10 *Marking Crayons* for identifying specimens.

3.14.11 *Scoop*, flat bottom, for batching aggregates.

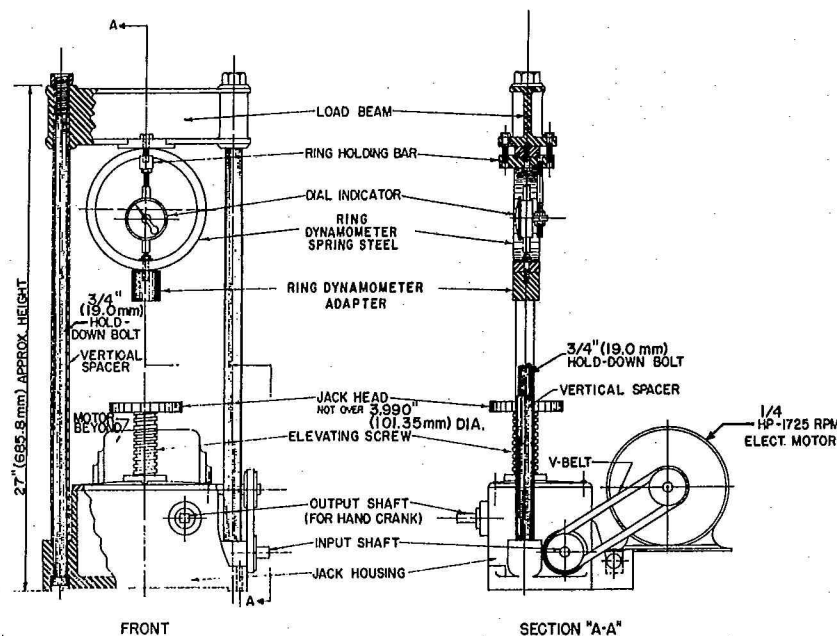
3.14.12 *Spoon*, large, for placing the mixture in the specimen molds.

4. Test Specimens

4.1 *Number of Specimens*—Prepare at least three specimens for each combination of aggregates and bitumen content.

4.2 *Preparation of Aggregates*—Dry aggregates to constant weight at 221 to 230°F (105 to 110°C) and separate the aggregates to dry-sieving into the desired size fractions.² The following size fractions are recommended:

- 1 to 3/4 in. (25.0 to 19.0 mm)
- 3/4 to 3/8 in. (19.0 to 9.5 mm)
- 3/8 in. to No. 4 (9.5 mm to 4.75 mm)
- No. 4 to No. 8 (4.75 mm to 2.36 mm)
- Passing No. 8 (2.36 mm)

4.3 *Determination of Mixing and Compacting Temperatures:*

4.3.1 The temperatures to which the asphalt cement and asphalt cut-back must be heated to produce a viscosity of 170 ± 20 cSt shall be the mixing temperature.

4.3.2 The temperature to which asphalt cement must be heated to produce a viscosity of 280 ± 30 cSt shall be the compacting temperature.

4.3.3 From a composition chart for the asphalt cut-back used, determine from its viscosity at 140°F (60°C) the percentage of solvent by weight. Also determine from the chart the viscosity at 140°F (60°C) of the asphalt cut-back

after it has lost 50 % of its solvent. The temperature determined from the viscosity temperature chart to which the asphalt cut-back must be heated to produce a viscosity of 280 ± 30 cSt after a loss of 50 % of the original solvent content shall be the compacting temperature.

4.3.4 The temperature to which tar must be heated to produce Engler specific viscosities of 25 ± 3 and 40 ± 5 shall be respectively the mixing and compacting temperature.

4.4 *Preparation of Mixtures:*

4.4.1 Weigh into separate pans for each test specimen the amount of each size fraction required to produce a batch that will result in a compacted specimen 2.5 ± 0.05 in. (63.5 ± 1.27 mm) in height (about 1200 g). Place the pans on the hot plate or in the oven and heat to a temperature not exceeding the mixing temperature established in 4.3 by more than approximately 50°F (28°C) for asphalt cement and tar mixes and 25°F (14°C) for cut-back asphalt mixes. Charge the mixing bowl with the heated aggregate and dry mix thoroughly. Form a crater in the dry blended aggregate and weigh the preheated required amount of bituminous material into the mixture. For mixes prepared with cutback asphalt introduce the mixing blade in the mixing bowl and determine the total weight of the mix components plus bowl and blade before proceeding with mixing. Care must be exercised to prevent loss of the mix during mixing and subsequent handling. At this point, the temperature of the aggregate and bituminous material shall be within the limits of the mixing temperature established in 4.3. Mix the aggregate and bituminous material rapidly until thoroughly coated.

4.4.2 Following mixing, cure asphalt cutback mixtures in a ventilated oven maintained at approximately 20°F (11.1°C) above the compaction temperature. Curing is to be continued in the mixing bowl until the precalculated weight of 50 % solvent loss or more has been obtained. The mix may be stirred in a mixing bowl during curing to accelerate the solvent loss. However, care should be exercised to prevent

² Detailed requirements for these sieves are given in ASTM Specification E 11, for Wire-Cloth Sieves for Testing Purposes see *Annual Book of ASTM Standards*, Vol 14.02.

 D 1559

loss of the mix. Weigh the mix during curing in successive intervals of 15 min initially and less than 10 min intervals as the weight of the mix at 50 % solvent loss is approached.

4.5 Compaction of Specimens:

4.5.1 Thoroughly clean the specimen mold assembly and the face of the compaction hammer and heat them either in boiling water or on the hot plate to a temperature between 200 and 300°F (93.3 and 148.9°C). Place a piece of filter paper or paper toweling cut to size in the bottom of the mold before the mixture is introduced. Place the entire batch in the mold, spade the mixture vigorously with a heated spatula or trowel 15 times around the perimeter and 10 times over the interior. Remove the collar and smooth the surface of the mix with a trowel to a slightly rounded shape. Temperatures of the mixtures immediately prior to compaction shall be within the limits of the compacting temperature established in 4.3.

4.5.2 Replace the collar, place the mold assembly on the compaction pedestal in the mold holder, and unless otherwise specified, apply 50 blows with the compaction hammer with a free fall in 18 in. (457.2 mm). During compaction, the operator shall hold the axis of the compaction hammer by hand as nearly perpendicular to the base of the mold assembly as possible. Remove the base plate and collar, and reverse and reassemble the mold. Apply the same number of compaction blows to the face of the reversed specimen. After compaction, remove the base plate and place the sample extractor on that end of the specimen. Place the assembly with the extension collar up in the testing machine, apply pressure to the collar by means of the load transfer bar, and force the specimen into the extension collar. Lift the collar from the specimen. Carefully transfer the specimen to a smooth, flat surface and allow it to stand overnight at room temperature. Weigh, measure, and test the specimen.

NOTE 5—The above procedure requires that the handle of the compaction hammer should be held freely by one hand in as nearly a vertical position as possible while hand compaction proceeds. Inevitably, this will result in some wobbling of the handle about the vertical as compaction takes place. This wobbling, however, provides a highly desirable kneading of the specimen during compaction, resulting in higher density. Consequently, for this standard test, no mechanical device of any kind should be used to restrict the handle of the hammer in the vertical position during compaction.

NOTE 6—In general, specimens shall be cooled as specified in 4.5.2. When more rapid cooling is desired, table fans may be used. Mixtures that lack sufficient cohesion to result in the required cylindrical shape on removal from the mold immediately after compaction may be cooled in the mold in air until sufficient cohesion has developed to result in the proper cylindrical shape.

5. Procedure

5.1 Bring the specimens prepared with asphalt cement or tar to the specified temperature by immersing in the water bath 30 to 40 min or placing in the oven for 2 h. Maintain the bath or oven temperature at $140 \pm 1.8^\circ\text{F}$ ($60 \pm 1.0^\circ\text{C}$) for the asphalt cement specimens and $100 \pm 1.8^\circ\text{F}$ ($37.8 \pm 1.0^\circ\text{C}$) for tar specimens. Bring the specimens prepared with asphalt cut-back to the specified temperature by placing them in the air bath for a minimum of 2 h. Maintain the air bath temperature at $77 \pm 1.8^\circ\text{F}$ ($25 \pm 1.0^\circ\text{C}$). Thoroughly clean the guide rods and the inside surfaces of the test heads prior to making the test, and lubricate the guide rods so that the upper test head slides freely over them. The testing-head

temperature shall be maintained between 70 to 100°F (21.1 to 37.8°C) using a water bath when required. Remove the specimen from the water bath, oven, or air bath, and place in the lower segment of the breaking head. Place the upper segment of the breaking head on the specimen, and place the complete assembly in position on the testing machine. Place the flowmeter, where used, in position over one of the guide rods and adjust the flowmeter to zero while holding the sleeve firmly against the upper segment of the breaking head. Hold the flowmeter sleeve firmly against the upper segment of the breaking head while the test load is being applied.

5.2 Apply the load to the specimen by means of the constant rate of movement of the load jack or testing-machine head of 2 in. (50.8 mm)/min until the maximum load is reached and the load decreases as indicated by the dial. Record the maximum load noted on the testing machine or converted from the maximum micrometer dial reading. Release the flowmeter sleeve or note the micrometer dial reading, where used, the instant the maximum load begins to decrease. Note and record the indicated flow value or equivalent units in hundredths of an inch (twenty-five hundredths of a millimetre) if a micrometer dial is used to measure the flow. The elapsed time for the test from removal of the test specimen from the water bath to the maximum load determination shall not exceed 30 s.

TABLE 1 Stability Correlation Ratios^A

Volume of Specimen, cm ³	Approximate Thickness of Specimen, in. ^B	mm	Correlation Ratio
200 to 213	1	25.4	5.56
214 to 225	1 ¹ / ₁₆	27.0	5.00
226 to 237	1 ¹ / ₈	28.6	4.55
238 to 250	1 ³ / ₁₆	30.2	4.17
251 to 264	1 ¹ / ₄	31.8	3.85
265 to 276	1 ⁵ / ₁₆	33.3	3.57
277 to 289	1 ³ / ₈	34.9	3.33
290 to 301	1 ⁷ / ₁₆	36.5	3.03
302 to 316	1 ¹ / ₂	38.1	2.78
317 to 328	1 ⁹ / ₁₆	39.7	2.50
329 to 340	1 ⁵ / ₈	41.3	2.27
341 to 353	1 ¹¹ / ₁₆	42.9	2.08
354 to 367	1 ³ / ₄	44.4	1.92
368 to 379	1 ¹³ / ₁₆	46.0	1.79
380 to 392	1 ⁷ / ₈	47.6	1.67
393 to 405	1 ¹⁵ / ₁₆	49.2	1.56
406 to 420	2	50.8	1.47
421 to 431	2 ¹ / ₁₆	52.4	1.39
432 to 443	2 ¹ / ₈	54.0	1.32
444 to 456	2 ³ / ₁₆	55.6	1.25
457 to 470	2 ¹ / ₄	57.2	1.19
471 to 482	2 ⁵ / ₁₆	58.7	1.14
483 to 495	2 ³ / ₈	60.3	1.09
496 to 508	2 ⁷ / ₁₆	61.9	1.04
509 to 522	2 ¹ / ₂	63.5	1.00
523 to 535	2 ⁹ / ₁₆	65.1	0.96
536 to 546	2 ⁵ / ₈	66.7	0.93
547 to 559	2 ¹¹ / ₁₆	68.3	0.89
560 to 573	2 ³ / ₄	69.8	0.86
574 to 585	2 ¹³ / ₁₆	71.4	0.83
586 to 598	2 ⁷ / ₈	73.0	0.81
599 to 610	2 ¹⁵ / ₁₆	74.6	0.78
611 to 625	3	76.2	0.76

^A The measured stability of a specimen multiplied by the ratio for the thickness of the specimen equals the corrected stability for a 2¹/₂-in. (63.5-mm) specimen.

^B Volume-thickness relationship is based on a specimen diameter of 4 in. (101.6 mm).

 D 1559

NOTE 7—For core specimens, correct the load when thickness is other than 2½ in. (63.5 mm) by using the proper multiplying factor from Table 1.

6. Report

6.1 The report shall include the following information:

6.1.1 Type of sample tested (laboratory sample or pavement core specimen).

NOTE 8—For core specimens, the height of each test specimen in inches (or millimetres) shall be reported.

6.1.2 Average maximum load in pounds-force (or newtons) of at least three specimens, corrected when required.

6.1.3 Average flow value, in hundredths of an inch, twenty-five hundredths of a millimetre, of three specimens, and

6.1.4 Test temperature.

The American Society for Testing and Materials takes no position respecting the validity of any patent rights asserted in connection with any item mentioned in this standard. Users of this standard are expressly advised that determination of the validity of any such patent rights, and the risk of infringement of such rights, are entirely their own responsibility.

This standard is subject to revision at any time by the responsible technical committee and must be reviewed every five years and if not revised, either reapproved or withdrawn. Your comments are invited either for revision of this standard or for additional standards and should be addressed to ASTM Headquarters. Your comments will receive careful consideration at a meeting of the responsible technical committee, which you may attend. If you feel that your comments have not received a fair hearing you should make your views known to the ASTM Committee on Standards, 1916 Race St., Philadelphia, PA 19103.