



Designation: D1481 – 17

# Standard Test Method for Density and Relative Density (Specific Gravity) of Viscous Materials by Lipkin Bicapillary Pycnometer<sup>1</sup>

This standard is issued under the fixed designation D1481; the number immediately following the designation indicates the year of original adoption or, in the case of revision, the year of last revision. A number in parentheses indicates the year of last reapproval. A superscript epsilon ( $\epsilon$ ) indicates an editorial change since the last revision or reapproval.

## 1. Scope\*

1.1 This test method covers the determination of the density of oils more viscous than 15 mm<sup>2</sup>/s (cSt) at 20 °C, and of viscous oils and melted waxes at elevated temperatures, but not at temperatures at which the sample would have a vapor pressure of 13.3 kPa (100 mmHg) or above.

NOTE 1—To determine the densities of less viscous liquids at 20 °C or 25 °C use Test Method [D1217](#).

1.2 This test method provides a calculation procedure for converting density to relative density (specific gravity).

1.3 **WARNING**—Mercury has been designated by many regulatory agencies as a hazardous material that can cause central nervous system, kidney and liver damage. Mercury, or its vapor, may be hazardous to health and corrosive to materials. Caution should be taken when handling mercury and mercury containing products. See the applicable product Safety Data Sheet (SDS) for details and EPA's website—<http://www.epa.gov/mercury/faq.htm>—for additional information. Users should be aware that selling mercury and/or mercury containing products into your state or country may be prohibited by law.

1.4 The values stated in SI units are to be regarded as standard.

1.4.1 *Exception*—Other units of measurement are included in this standard for information only.

1.5 *This standard does not purport to address all of the safety concerns, if any, associated with its use. It is the responsibility of the user of this standard to establish appropriate safety and health practices and determine the applicability of regulatory limitations prior to use.*

1.6 *This international standard was developed in accordance with internationally recognized principles on standardization established in the Decision on Principles for the Development of International Standards, Guides and Recom-*

*mendations issued by the World Trade Organization Technical Barriers to Trade (TBT) Committee.*

## 2. Referenced Documents

2.1 *ASTM Standards:*<sup>2</sup>

[D1217 Test Method for Density and Relative Density \(Specific Gravity\) of Liquids by Bingham Pycnometer](#)

[D1250 Guide for Use of the Petroleum Measurement Tables](#)

[D4052 Test Method for Density, Relative Density, and API Gravity of Liquids by Digital Density Meter](#)

## 3. Terminology

3.1 *Definitions:*

3.1.1 *density, n*—mass per unit volume at a specified temperature. **D4052**

3.1.2 *relative density (specific gravity), n*—the ratio of the density of a material at a stated temperature to the density of water at a stated temperature. **D4052**

## 4. Summary of Test Method<sup>3</sup>

4.1 The liquid is drawn into the bicapillary pycnometer through the removable siphon arm and adjusted to volume at the temperature of test, in such a manner that there is practically no drainage in the unfilled tubing. After equilibration at the test temperature, liquid levels are read, and the pycnometer is removed from the thermostated bath, cooled to room temperature, and weighed.

4.2 Density or relative density (specific gravity), as desired, is then calculated from the volume at the test temperature and the weight of the sample. The effect of air buoyancy is included in the calculations.

<sup>1</sup> This test method is under the jurisdiction of ASTM Committee [D02](#) on Petroleum Products, Liquid Fuels, and Lubricants and is the direct responsibility of Subcommittee [D02.04.0D](#) on Physical and Chemical Methods.

Current edition approved June 1, 2017. Published July 2017. Originally approved in 1957. Last previous edition approved in 2012 as D1481 – 12. DOI: 10.1520/D1481-17.

<sup>2</sup> For referenced ASTM standards, visit the ASTM website, [www.astm.org](http://www.astm.org), or contact ASTM Customer Service at [service@astm.org](mailto:service@astm.org). For *Annual Book of ASTM Standards* volume information, refer to the standard's Document Summary page on the ASTM website.

<sup>3</sup> For a more complete discussion of this procedure, see Lipkin, M. R., Mills, I. W., Martin, C. C., and Harvey, W. T., *Analytical Chemistry*, ANCHA, Vol 21, 1949, p. 504.

\*A Summary of Changes section appears at the end of this standard

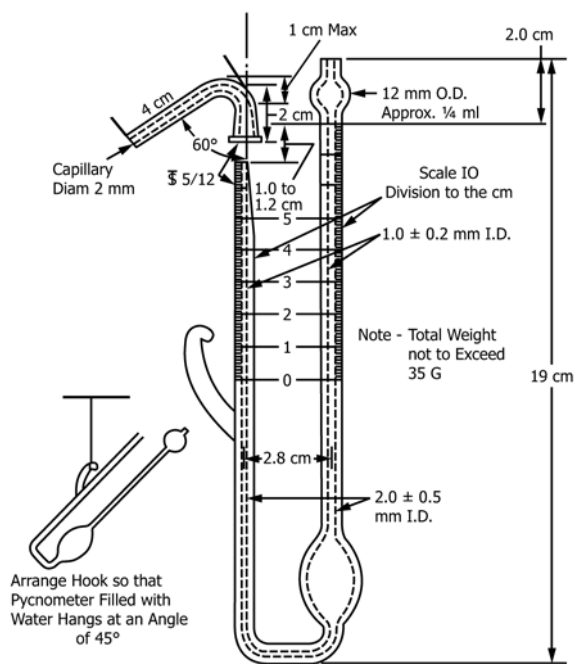

FIG. 1 Pycnometer

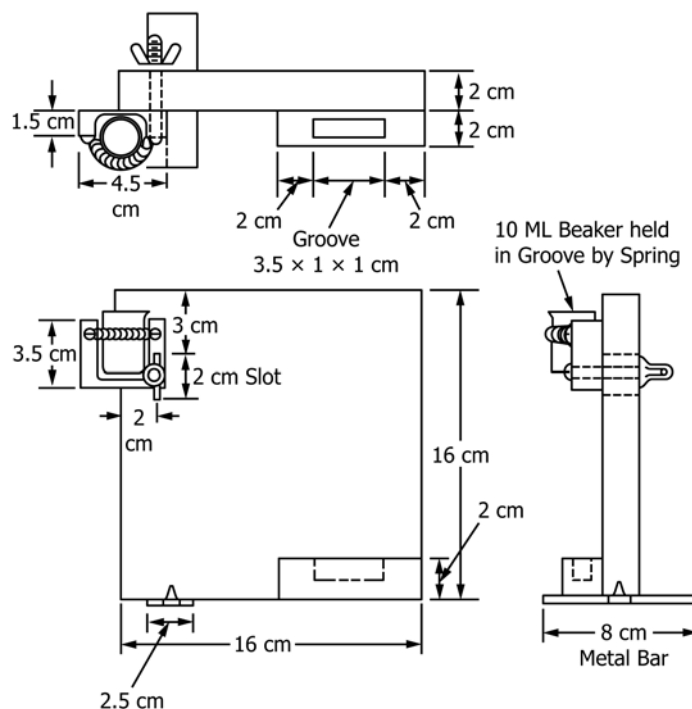

FIG. 2 Rack for Filling Pycnometer

## 5. Significance and Use

5.1 Density is a fundamental physical property that can be used in conjunction with other properties to characterize both the light and heavy fractions of petroleum and to access the quality of crude oils.

5.2 Determination of the density or relative density of petroleum and its products is necessary for the conversion of measured volumes to volumes at the standard temperatures of 15 °C.

5.3 The determination of densities at the elevated temperatures of 40 °C and 100 °C is particularly useful in providing the data needed for the conversion of kinematic viscosities in centistokes (mm<sup>2</sup>/s) to the corresponding dynamic viscosities in centipoises (mPa·s).

## 6. Apparatus

6.1 *Pycnometer*<sup>4</sup>—A side-arm type of pycnometer conforming to the dimensions given in Fig. 1 and made of borosilicate glass. The weight shall not exceed 35 g without the side arm.

6.2 *Rack*—A rack to use in filling the pycnometer (see Fig. 2).

6.3 *Constant-Temperature Oven*—An oven for use in filling the pycnometer. Any oven capable of holding the filling rack, and of maintaining a temperature of approximately 100 °C, can be used.

6.4 *Constant-Temperature Bath*—A mixture of water and glycerin, or oil bath having a depth of at least 305 mm (12 in.) and provided with heating, stirring, and thermostating devices adequate to maintain desired temperatures in the range from 20 °C to 100 °C with an accuracy of ±0.01 °C.

6.5 *Bath Thermometers*—Thermometers graduated in 0.1 °C subdivisions and standardized for the range of use to the nearest 0.01 °C (ASTM Saybolt Viscosity Thermometers 17C to 22C are recommended). For most hydrocarbons, the density coefficient is about 0.0008 units/°C, and therefore a temperature error of ±0.013 °C would cause an error of ±0.000 01 in density.

6.6 *Pycnometer Holder*—A holder, as shown in Fig. 3, is recommended for supporting the pycnometer in the bath. A single clamp device may be used.

6.7 *Balance*—A balance able to reproduce weighings within 0.1 mg when carrying a load of 35 g or less on each pan. The balance shall be located in a room shielded from drafts and fumes and in which the temperature changes between related weighings (empty and filled pycnometer) do not cause a significant change in the ratio of the balance arms. Otherwise, weighings shall be made by the substitution method in which the calibrated weights and pycnometer are alternatively weighed on the same balance pan. The same balance shall be used for all related weighings.

6.8 *Weights*—Weights shall be used whose relative values are known to the nearest 0.05 mg or better. The same set of weights shall be used for the calibration of the pycnometer and the determination of the densities, or the sets of weights shall be calibrated relative to each other.

<sup>4</sup> The sole source of supply of the pycnometers known to the committee at this time is Reliance Glass Co., 220 Gateway Rd., Bensenville, IL 60106-0825. If you are aware of alternative suppliers, please provide this information to ASTM International Headquarters. Your comments will receive careful consideration at a meeting of the responsible technical committee,<sup>1</sup> which you may attend.

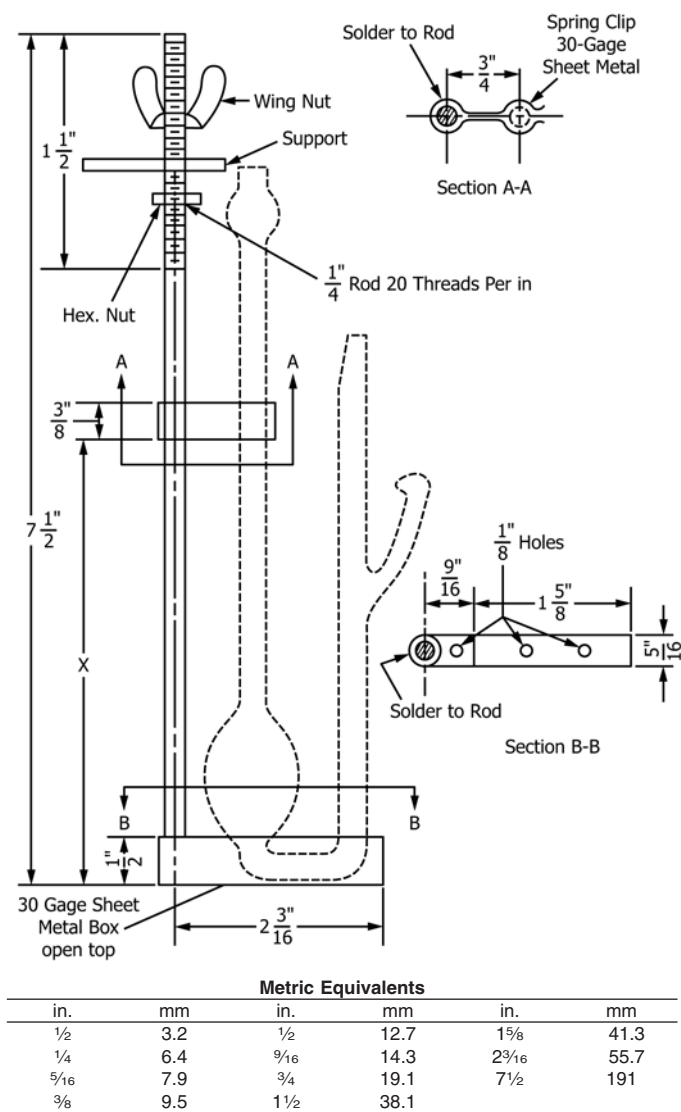

FIG. 3 Pycnometer Holder

## 7. Reagents and Materials

7.1 *Acetone*—(Warning—Extremely flammable. Use adequate ventilation.)

7.2 *Isopentane*—(Warning—Extremely flammable. Avoid buildup of vapors and remove all sources of ignition, especially nonexplosion-proof electrical apparatus.)

7.3 *Chromic Acid (Potassium Dichromate/Conc. Sulfuric Acid)*—(Warning—Causes severe burns. A recognized carcinogen. Do not get in eyes, on skin or clothing.)

7.4 *Xylenes*—(Warning—Flammable liquid. Aspiration hazard. May irritate skin, eyes, respiratory tract or digestive tract, or both. May cause central nervous system depression, liver and kidney damage, or exhibit reproductive and fetal effects, or both.)

## 8. Preparation of Apparatus

8.1 Thoroughly clean the pycnometer and side arm with hot chromic acid cleaning solution (Warning—See 7.4). Chromic

acid solution is the most effective cleaning agent. However, surfactant cleaning fluids have also been used successfully. Rinse well with distilled water; and dry at 105 °C to 110 °C for at least 1 h, preferably with a slow current of filtered air passing through the pycnometer. Cleaning shall be done in this manner whenever the pycnometer is to be calibrated or whenever liquid fails to drain cleanly from the walls of the pycnometer or its capillary. Ordinarily, the pycnometer may be cleaned between determinations by washing with a suitable solvent, such as isopentane or xylenes, and vacuum drying. If acetone is used as the wash liquid, the pycnometer should then be rinsed with isopentane or xylenes.

## 9. Calibration of Pycnometer

9.1 Weigh the clean, dry pycnometer (without the side arm) to the nearest 0.1 mg, and record the weight.

9.2 Fill the pycnometer with freshly boiled distilled water. This may be conveniently done by placing the pycnometer in the holder with the side arm dipping into a sample cup containing water. Allow the pycnometer to fill by siphoning. Break the siphon by removing the side arm when the liquid level in the bulb arm of the pycnometer reaches 6 on the scale.

9.3 Remove the side arm which was used to fill the pycnometer and remove excess liquid from the capillary tip by wiping with a small piece of absorbent paper.

9.4 Place the pycnometer in the holder in the constant-temperature bath at temperature  $t$  with the liquid level in the capillaries below the liquid level in the bath. When the liquid level has reached equilibrium (not less than 15 min), read the scale to the nearest 0.2 small division at the liquid level in each arm. After 5 min, read the liquid level again. If the sum of the scale readings in each reading differs by more than  $\pm 0.04$ , repeat readings at 5 min intervals. When readings are constant, record.

9.5 Remove the pycnometer from the bath and allow it to come to room temperature. Rinse the outer surface with distilled water, with acetone, then with redistilled xylenes, and dry thoroughly with a chemically clean lint-free cloth, slightly damp with water. Allow to stand a few minutes, and then weigh to nearest 0.1 mg.

NOTE 2—In atmospheres of low humidity (60 % or lower), drying the pycnometer by rubbing with dry cotton cloth will induce static charges equivalent to a loss of about 1 mg or more in the weight of the pycnometer. This charge may not be completely dissipated in less than 1/2 h and can be detected by touching the pycnometer to the wire hook on the balance and then drawing it away slowly. If the pycnometer exhibits an attraction for the wire hook, it may be considered to have a static charge.

9.6 Repeat the above, but break the siphon when water has reached the 3 mark in the bulb arm, and in the next experiment, at the 0 mark in the bulb arm. Obtain the apparent volume for each filling by dividing the weight of water held by the pycnometer in each experiment by the density of water at the calibration temperature  $t$ . Calibration shall be made at 20 °C, 40 °C, and 50 °C. Prepare a calibration curve for 20 °C by plotting the sum of the two scale readings versus the apparent volume at 20 °C. If the curve is not a straight line, and future

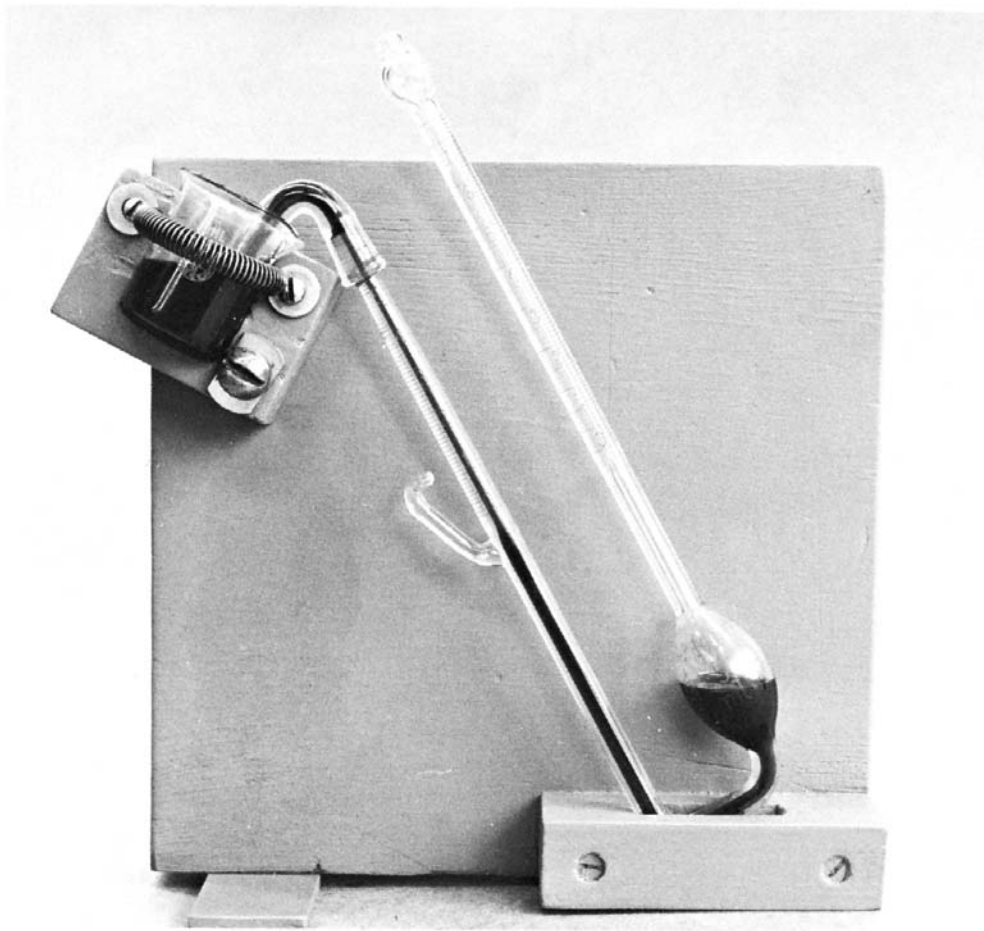

FIG. 4 Pycnometer Filling Assembly

checks do not correct it, discard the pycnometer. The line shall not be more than 0.0002 mL/unit from any one determined point.

9.7 Corresponding calibration curves shall be made for 40 °C and 50 °C. These calibration curves are checked using the following equation:

$$V_2 = V_1(1 + ct) \quad (1)$$

where:

- $V_2$  = apparent volume at test temperature,
- $V_1$  = apparent volume at 20 °C, and
- $c$  = cubical coefficient of expansion of borosilicate glass ( $9.9 \times 10^{-6}/^{\circ}\text{C}$ ).

The calculated and determined curves at 40 °C and 50 °C should check to within  $\pm 0.0002$  mL/unit at all points. The calibration curves for higher temperatures shall be obtained by calculation.

## 10. Procedure

10.1 Weigh the clean, dry pycnometer, without the side arm, to 0.1 mg and record the weight.

10.2 Place a 10 mL sample beaker in the wooden rack (Fig. 2). Before attaching the side arm to the pycnometer, drain a few drops of sample through the side arm to wet the inside

surface and reduce the chance of trapping air bubbles in the capillary during the filling operation. Place the side arm on the pycnometer, and place the assembly on the rack with the side arm dipping into the sample beaker as shown in Fig. 4.

10.3 In filling the pycnometer with very viscous oils or high-melting waxes, place the whole filling assembly in a hot-air oven to facilitate filling. An oven at approximately 100 °C is usually hot enough for this purpose.

10.4 Apply gentle suction to the bulb arm of the pycnometer to start the siphoning action. The suction must be gentle to avoid the formation of bubbles. After siphoning is started, allow filling by siphoning to continue until the liquid level in the bulb arm ceases to rise. Then remove the pycnometer from the rack and place in the thermostated bath, in the same tilted position, until the oil ceases to contract. At this point, place the pycnometer in an upright position, and allow the liquid level in the bulb arm to reach the upper portion of the calibrated capillary, but not above 6.4. Stop siphoning by removing the side arm.

NOTE 3—With viscous oils, it will reduce drainage errors to fill to the 6.0 to 6.4 mark, and it may be necessary to apply a little suction to the long arm during cooling to prevent the meniscus in the bulb arm from falling. Maintain the meniscus at about the same level in the long arm throughout the whole determination.

**TABLE 1 Vacuum Corrections**

Correction <sup>A</sup> Plus		Correction <sup>A</sup> Plus	
0.70	0.000 36	0.85	0.000 18
0.71	0.000 35	0.86	0.000 17
0.72	0.000 33	0.87	0.000 16
0.73	0.000 32	0.88	0.000 14
0.74	0.000 31	0.89	0.000 13
0.75	0.000 30	0.90	0.000 12
0.76	0.000 29	0.91	0.000 11
0.77	0.000 28	0.92	0.000 10
0.78	0.000 26	0.93	0.000 09
0.79	0.000 25	0.94	0.000 07
0.80	0.000 24	0.95	0.000 06
0.81	0.000 23	0.96	0.000 05
0.82	0.000 22	0.97	0.000 04
0.83	0.000 20	0.98	0.000 03
0.84	0.000 19	0.99	0.000 01

<sup>A</sup>This table applies for all air density values between 0.0011 g/mL and 0.0013 g/mL. For air densities outside this range, the vacuum correction shall be calculated from the equation  $C = (d_s/0.998\ 23) \times [0.998\ 23 - (W/V)]d_a$ , being the density of the air in the balance case in grams per millilitre.

10.5 After removing the side-arm cap from the short arm of the pycnometer, wipe the tip and ground joint of the pycnometer, and adjust it to an upright position in the thermostated bath. The bath liquid level shall be above the 6 mark on the pycnometer and below the ground glass tip of the pycnometer.

10.6 Allow 15 min for equilibrium to be obtained. After the stated 15 min time for coming to equilibrium, read the meniscus levels in both arms of the pycnometer to the nearest 0.2 of the smallest scale division. Wait 5 min and check readings. If the sum of the readings at the two different times do not agree to within  $\pm 0.04$ , repeat at 5 min intervals until checks are obtained. Record the sum of these readings and also record the corresponding apparent volume from the calibration curve for the same temperature.

NOTE 4—The final level of oil in the pycnometer should not be more than 5 mm below the tip of the ground glass end of the pycnometer, and the level in the long (bulb) side of the pycnometer should be no lower than it has been at any time during the procedure. With these precautions, drainage error (which is important with very viscous samples) is entirely eliminated.

10.7 Remove the pycnometer from the bath and tilt it so that the liquid moves down in the short arm and up in the bulb arm. Clean and dry the outside of the pycnometer as described in the calibration procedure (Section 9). Allow to come to balance room temperature. Weigh to the nearest 0.1 mg. Subtract the weight of empty pycnometer, without the side arm, to get the weight of sample.

## 11. Calculation

11.1 Calculate the density of the sample, corrected to vacuum, by the following equation:

$$\text{Density in vacuum, } d_s, \text{ g/mL} = (W/V) + C \quad (2)$$

where:

- $W$  = weight of sample in air, g,
- $V$  = apparent volume, mL, and
- $C$  = vacuum correction, obtained from Table 1.

**TABLE 2 Density of Water<sup>A</sup>**

Temperature, °C	Density, g/mL	Temperature, °C	Density, g/mL	Temperature, °C	Density, g/mL
0.01	0.999 844	21.0	0.997 996	40.0	0.992 216
3.0	0.999 967	22.0	0.997 773	45.0	0.990 213
4.0	0.999 975	23.0	0.997 541	50.0	0.988 035
5.0	0.999 967	24.0	0.997 299	55.0	0.985 693
10.0	0.999 703	25.0	0.997 048	60.0	0.983 196
15.0	0.999 103	26.0	0.996 786	65.0	0.980 551
15.56	0.999 016	27.0	0.996 516	70.0	0.977 765
16.0	0.998 946	28.0	0.996 236	75.0	0.974 843
17.0	0.998 778	29.0	0.995 947	80.0	0.971 790
18.0	0.998 599	30.0	0.995 650	85.0	0.968 611
19.0	0.998 408	35.0	0.994 033	90.0	0.965 310
20.0	0.998 207	37.78	0.993 046	99.9	0.958 421

<sup>A</sup>Densities conforming to the International Temperature Scale 1990 (ITS 90) were extracted from Lemmon, E. W., McLinden, M. O., and Friend, D. G., "Thermophysical Properties of Fluid Systems" in NIST Chemistry WebBook, NIST Standard Reference Database Number 69, Eds. P.J. Linstrom and W.G. Mallard, National Institute of Standards and Technology, Gaithersburg MD, 20899, <http://webbook.nist.gov>, (retrieved July 24, 2013).

11.2 Calculate the relative density (specific gravity) of the sample at  $t_1/t_2$  by dividing the density, as calculated in 10.1, by the density of water at the reference temperature,  $t_2$ , as obtained from Table 2. Relative density (specific gravity) at  $t_1/15.56$  °C ( $t/60$  °F where  $t$  is expressed in degrees Fahrenheit) can be changed to the conventional 15.56/15.56 °C (60/60 °F) relative density (specific gravity) by use of the appropriate Table 23 in Guide D1250, provided that the glass expansion factor has been excluded.

11.3 In reporting density, give the test temperature and the units (for example, density at 40 °C = x.xxxx g/mL). In reporting relative density (specific gravity), give both the test temperature and the reference temperature, but no units (for example, relative density (specific gravity), 40 °C/15.56 °C = x.xxxx). Carry out all calculations to five figures, and round off the final results to four figures.

## 12. Precision and Bias

12.1 The precision of the test method as obtained by statistical examination of interlaboratory test results is as follows:

12.1.1 *Repeatability*—The difference between successive test results obtained by the same operator with the same apparatus under constant operating conditions on identical test material, would in the long run, in the normal and correct operation of the test method, exceed the following value only in one case in twenty:

Pycnometer Volume, mL	Repeatability, g/mL
10	0.000 15

12.1.2 *Reproducibility*—The difference between two single and independent results, obtained by different operators working in different laboratories on identical test material, would in the long run, in the normal and correct operation of the test method, exceed the following value only in one case in twenty:

Pycnometer Volume, mL	Reproducibility, g/mL
10	0.000 35

NOTE 5—If pycnometers of other than 10 mL in volume are used, this precision statement may not apply.

12.2 *Bias*—The difference of results from the established value when compared to pure reference materials is not expected to be more than 0.000 35 g/mL. Specific bias has not been established by cooperative testing.

### 13. Keywords

13.1 density; gravity; pycnometer; relative density; specific gravity

## SUMMARY OF CHANGES

Subcommittee D02.04 has identified the location of selected changes to this standard since the last issue (D1481 – 12) that may impact the use of this standard. (Approved June 1, 2017.)

(1) Revised water density reference values in **Table 2**.

*ASTM International takes no position respecting the validity of any patent rights asserted in connection with any item mentioned in this standard. Users of this standard are expressly advised that determination of the validity of any such patent rights, and the risk of infringement of such rights, are entirely their own responsibility.*

*This standard is subject to revision at any time by the responsible technical committee and must be reviewed every five years and if not revised, either reapproved or withdrawn. Your comments are invited either for revision of this standard or for additional standards and should be addressed to ASTM International Headquarters. Your comments will receive careful consideration at a meeting of the responsible technical committee, which you may attend. If you feel that your comments have not received a fair hearing you should make your views known to the ASTM Committee on Standards, at the address shown below.*

*This standard is copyrighted by ASTM International, 100 Barr Harbor Drive, PO Box C700, West Conshohocken, PA 19428-2959, United States. Individual reprints (single or multiple copies) of this standard may be obtained by contacting ASTM at the above address or at 610-832-9585 (phone), 610-832-9555 (fax), or [service@astm.org](mailto:service@astm.org) (e-mail); or through the ASTM website ([www.astm.org](http://www.astm.org)). Permission rights to photocopy the standard may also be secured from the Copyright Clearance Center, 222 Rosewood Drive, Danvers, MA 01923, Tel: (978) 646-2600; <http://www.copyright.com/>*