



Standard Test Methods for Sampling and Testing Bitumen-Saturated Felts and Woven Fabrics for Roofing and Waterproofing¹

This standard is issued under the fixed designation D146/D146M; the number immediately following the designation indicates the year of original adoption or, in the case of revision, the year of last revision. A number in parentheses indicates the year of last reapproval. A superscript epsilon (ε) indicates an editorial change since the last revision or reapproval.

This standard has been approved for use by agencies of the U.S. Department of Defense.

^{ε1} NOTE—Units information was editorially corrected in June 2012.

1. Scope

1.1 These test methods cover the sampling and examination of felts or woven fabrics, saturated or impregnated but not coated with asphaltic or coal-tar materials, for use in waterproofing or for the construction of built-up roof coverings.

1.2 The values stated in either SI units or inch-pound units are to be regarded separately as standard. The values stated in each system may not be exact equivalents; therefore, each system shall be used independently of the other. Combining values from the two systems may result in non-conformance with the standard.

1.3 *This standard does not purport to address all of the safety concerns, if any, associated with its use. It is the responsibility of the user of this standard to establish appropriate safety and health practices and determine the applicability of regulatory limitations prior to use.*

2. Referenced Documents

2.1 ASTM Standards:²

D95 Test Method for Water in Petroleum Products and Bituminous Materials by Distillation

¹ These test methods are under the jurisdiction of ASTM Committee D08 on Roofing and Waterproofing and are the direct responsibility of Subcommittee D08.04 on Felts, Fabrics and Bituminous Sheet Materials.

Current edition approved May 1, 2012. Published June 2012. Originally approved in 1922. Last previous edition approved in 2004 as D146 – 04. DOI: 10.1520/D0146_D0146M-04R12E01.

² For referenced ASTM standards, visit the ASTM website, www.astm.org, or contact ASTM Customer Service at service@astm.org. For *Annual Book of ASTM Standards* volume information, refer to the standard's Document Summary page on the ASTM website.

D645/D645M Test Method for Thickness of Paper and Paperboard (Withdrawn 2010)³

D828 Test Method for Tensile Properties of Paper and Paperboard Using Constant-Rate-of-Elongation Apparatus (Withdrawn 2009)³

D1079 Terminology Relating to Roofing and Waterproofing
D1682 Test Method for Breaking Load and Elongation of Textile Fabric (Withdrawn 1992)³

D1910 Methods of Test for Construction Characteristics of Woven Fabrics; Replaced by D 3773, D 3774, D 3775, D 3776, D 3882, D 3883 (Withdrawn 1981)³

D4072 Test Method for Toluene-Insoluble (TI) Content of Tar and Pitch

D4312 Test Method for Toluene-Insoluble (TI) Content of Tar and Pitch (Short Method)

3. Sampling

3.1 From each shipment of the specified saturated felt or fabric, select at random a number of rolls equal to one half the cube root of the total number of rolls in the lot. If the specification requires sampling during manufacture, consider the lot to be the planned production quantity and select the rolls at uniformly spaced time intervals throughout the production period. The minimum sample shall consist of five rolls. If the calculated number is fractional, express it as the next highest whole number. For convenience, the following table, showing the number of rolls to be selected from lots of various sizes, is given:

³ The last approved version of this historical standard is referenced on www.astm.org.

Number of Rolls in Shipment	Number of Rolls in Sample	$g/m^2 = A/BC(oz/yd^2 = 1728 A/BC)$ (2)
Up to 1 000	5	
1 001 to 1 728	6	
1 729 to 2 744	7	
2 745 to 4 096	8	
4 097 to 5 832	9	
5 833 to 8 000	10	
8 001 to 10 648	11	
10 649 to 13 842	12	
13 843 to 17 576	13	
17 577 to 21 952	14	

The rolls so selected constitute the representative sample used for all subsequent observations and tests pertaining to the lot of material being examined. Identify each individual roll.

EXAMINATION OF REPRESENTATIVE SAMPLE

4. Gross Mass per Roll

4.1 Weigh each roll, intact, to the nearest 100 g [$\frac{1}{4}$ lb], and record each weight as the gross mass of that roll.

5. Mass of Wrapping Material and Mandrel (Core)

5.1 Strip each roll of its wrappings and weigh it to the nearest 100 g [$\frac{1}{4}$ lb]. If mandrels (cores) are used, collect them after the rolls are unwound and weigh them together, to the nearest 100 g [$\frac{1}{4}$ lb]. Calculate the average mass of the wrappings and mandrels per roll and record.

6. Mandrels (Cores)

6.1 Determine the shape of the cross section of the mandrels (cores) and report. If circular, measure the outside diameter to the nearest 1 mm [$\frac{1}{32}$ in.]. If square, measure each outside edge to the nearest 1 mm [$\frac{1}{32}$ in.]. Measure and report the length of the mandrel projecting beyond each end of each roll to the nearest 5 mm [$\frac{3}{16}$ in.].

7. Net Mass

7.1 Subtract the average mass of the wrappings and mandrels (Section 5) from the gross mass of each roll (Section 4) and record as the net mass of each roll. Calculate the average net mass per roll of the representative sample and record as the average for the lot.

8. Appearance and Dimensions of Rolls

8.1 Unwind the rolls. Observe the workmanship and finish, and record pertinent defects. Measure and record the length of each roll to the nearest 25 mm [1 in.] and its width to the nearest 1 mm [$\frac{1}{16}$ in.]. Calculate and record the area of material contained in each roll to the nearest 0.1 m² [1 ft²].

8.2 Measure and record the width of the selvage of each roll to the nearest 1 mm [$\frac{1}{16}$ in.].

9. Net Mass per Unit Area

9.1 From the net mass (Section 7) and the dimensions (Section 8), calculate the net mass per unit area for each roll, as follows:

For Felts:

$$g/m^2 = A/BC(lb/100 ft^2 = 1200 A/BC) \quad (1)$$

For Fabrics:

where:

A = net mass of rolls, kg [lb],

B = width of material, m [ft], and

C = length of material, m [ft].

Calculate the average net mass per unit area for the rolls in the representative sample and record it as the average for the lot.

10. Selecting a Representative Specimen

10.1 Examine in detail the roll having the unit net mass closest to the average unit net mass of the lot. Discard the outside convolution and cut a specimen the full width of the roll. Make the cuts perpendicular to the sides of the roll, straight and 750 mm [30 in.] apart, to the nearest 1 mm [$\frac{1}{32}$ in.]. Collect loose material, such as sand, if any, that may become detached from the specimen. Measure the width of the specimen to the nearest 2 mm [$\frac{1}{16}$ in.]. Weigh it, together with any detached surfacing, to the nearest 1 g. Calculate the net mass per unit area as follows:

For Felts:

$$g/m^2 = 1333.3D/E(lb/ft^2 = 1.0582 D/E) \quad (3)$$

For Fabrics:

$$g/m^2 = 1333.3D/E(oz/yd^2 = 1.5238 D/E) \quad (4)$$

where:

D = mass of the specimen, g, and

E = width of the specimen, mm [in.].

The mass so determined shall be within 1 % of the average net mass per unit area (Section 9). If the specimen so selected fails to conform to this requirement, cut additional specimens from the same roll until one of the proper mass is obtained. Use this specimen for further examination as described in Sections 11 – 16.

11. Detached Comminuted Surfacing

11.1 If the material is surfaced with sand or other finely comminuted material, sweep the detached surfacing from the representative specimen with an Osborn brush (or equivalent), brushing in one direction only. Combine the comminuted material thus removed with the loose material, collected as described in Section 10, and weigh both together to the nearest 1 g. Calculate this mass in g/m² [lb/100 ft²], record, and report as detached comminuted surfacing.

NOTE 1—The Osborn No. 322 Master Duster is the brush prescribed in Section 11. It is filled with Tampico fiber bristles projecting 73 mm [2.9 in.] from its holder.⁴

12. Moisture

12.1 From the representative specimen, cut four 50- by 460-mm [2- by 18-in.] test specimens, as shown in A-1 and A-2

⁴ The sole source of supply of the apparatus (Osborn No. 322 Master Duster) known to the committee at this time is Osborn Manufacturing Co., 5401 Hamilton Ave., Cleveland, OH 44114. (If required in less than dozen lots, the order must be marked "For ASTM Test.") If you are aware of alternative suppliers, please provide this information to ASTM International Headquarters. Your comments will receive careful consideration at a meeting of the responsible technical committee,¹ which you may attend.

of Fig. 1. Cut them into 25-mm [1-in.] squares and select about 50 g, at random. Weigh to the nearest 0.1 g and distill with 100 mL of solvent as prescribed in Test Method D95. Read the volume of water collected in the trap and calculate to grams on the basis that 1 mL weighs 1 g. Calculate the moisture to the nearest 0.5 % of the mass of the specimen used (including the detached comminuted surfacing, if any) and report as moisture, percentage of net mass.

NOTE 2—Any sample taken for determination of moisture shall be protected from the time of sampling against change in moisture by enclosing it in a substantially moisture-proof container.

13. Strength

13.1 Felts:

13.1.1 From the representative specimen, cut ten rectangular test strips, 25 by 150 mm [1 by 6 in.] with the fiber grain, as shown at B-1 to B-10 in Fig. 1, and ten strips across the grain, as shown at C-1 to C-10 in Fig. 1. Discard any specimens of perforated felt in which a perforation is within 1 mm [$1/32$ in.] of an edge. Condition both sets in air at $23 \pm 2^\circ\text{C}$ [$73.4 \pm 3.6^\circ\text{F}$] for at least 2 h, and test in a room maintained at the same temperature. In case of dispute, specimens shall also be conditioned in a controlled relative humidity of $50 \pm$

5 %. Determine the strength in accordance with Test Method D828, except as modified herein. At the start of the test, set apart the edges of the jaws of the clamps at 75 ± 3 mm [3.0 ± 0.1 in.]. Use a pendulum-type tensile tester with a driven clamp speed of 305 mm [12 in.]/min, or a load-cell-type tensile tester with a rate of jaw separation of 51 mm [2 in.]/min, and a response time of 1.25 s (or faster). Cut additional strips from adjacent areas of the representative specimen when needed because of discarded specimens or false breaks. False breaks occur within 1 in. of the clamping surfaces of the tensile tester jaws. Average the ten readings for each set and multiply by 0.04 to yield the strength in kN/m. Report to the nearest 0.1 kN/m for both with and across the fiber grain, respectively.

13.1.2 Precision⁵—The following data should be used for judging the acceptability of results (95 % probability) on samples from the same lot from the same supplier:

13.1.2.1 Repeatability—Duplicate results by the same operator should not be considered suspect unless they differ by more than the following amount:

⁵ Supporting data are available from ASTM International Headquarters. Request RR:D08-1005.

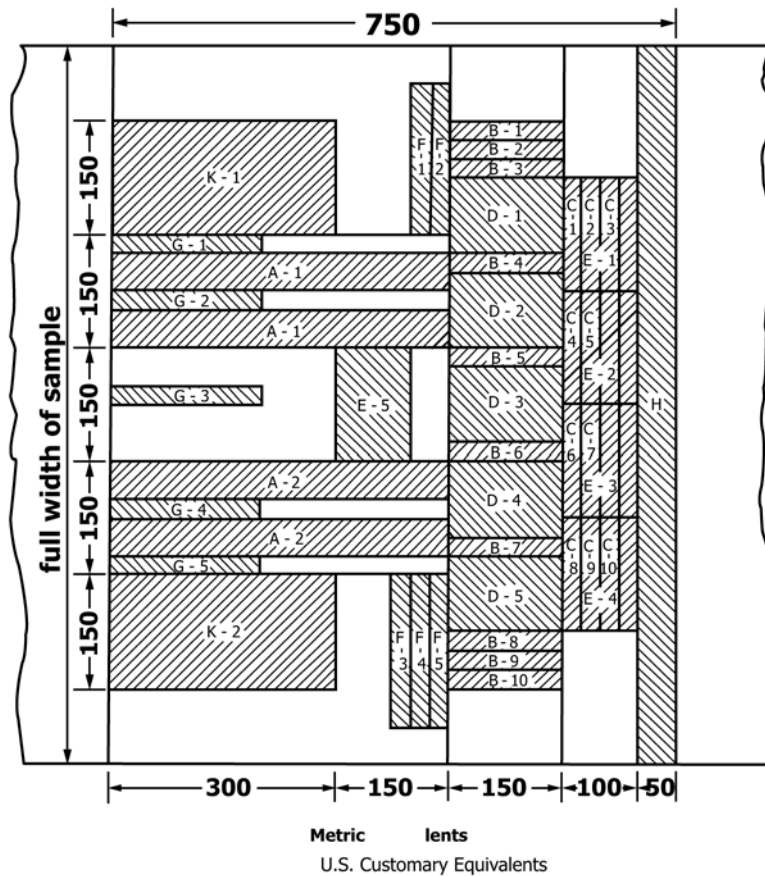

NOTE 1—All dimensions are in millimetres.

FIG. 1 Location of Test Pieces in Representative Specimen

Pendulum method	±15 %
Load-Cell method	±15 %

13.1.2.2 *Reproducibility*—The results submitted by each of two laboratories should not be considered suspect unless they differ by more than the following amounts:

Pendulum method	±15 %
Load-Cell method	±15 %

13.2 *Fabrics*—From the representative specimen, cut five 100- by 150-mm [4- by 6-in.] test pieces with the longer dimension parallel to the warp yarns, as shown at E-1 to E-5 in Fig. 1. Test these pieces at $21 \pm 1^\circ\text{C}$ [$69.8 \pm 1.8^\circ\text{F}$] in accordance with the grab method described in Test Methods D1682.

NOTE 3—As a referee method, or in case any dispute arises regarding the strength, repeat the test, with the exception that the fabric before being tested shall be exposed at least 2 h in an atmosphere of 65 % relative humidity at $21 \pm 1^\circ\text{C}$ [$69.8 \pm 1.8^\circ\text{F}$].

14. Pliability

14.1 *Felts*—From the representative specimen, cut ten 25- by 200-mm [1- by 8-in.] test pieces, five in the direction of and five across the fiber grain, as shown at F-1 to F-5, and at G-1 to G-5 in Fig. 1, respectively. Immerse them in water at $25 \pm 1^\circ\text{C}$ [$77 \pm 1.8^\circ\text{F}$] for 10 to 15 min; then remove each specimen separately and immediately bend it 90° over the rounded edge of a block at a uniform speed in approximately 2 s. The block shall be 75 mm [3 in.] square by 50 mm [2 in.] thick, with one long edge rounded on a radius of 12.7 mm [0.50 in.] and another edge on the same 75 mm [3 in.] face rounded on a radius of 19 mm [0.75 in.]. In bending, hold the specimen tightly against the upper 50-mm [2-in.] face of the block and bend its projecting end over the specified rounded edge without exerting any stress other than that required to keep the specimen in contact with the block and to avoid kinking. Consider any surface rupture visible to the normal eye and exceeding 3 mm [$\frac{1}{8}$ in.] in length as a failure.

14.2 *Fabrics*—Cut five 25- by 200-mm [1- by 8-in.] test pieces from the representative specimen in the direction of the warp, as shown at G-1 to G-5 in Fig. 1. Immerse them in a cooling mixture of ice and water at 0°C [32°F] for 10 to 15 min; then remove each specimen separately and immediately bend it over a 1.60-mm [$\frac{1}{16}$ -in.] diameter mandrel through an arc of 180° at a uniform speed in approximately 2 s and then through 360° over the same mandrel in the opposite direction. Dry the specimens thoroughly and examine them. If one or more of the test specimens crack, cut ten specimens from another portion of the sample and repeat the test. If one or more of these specimens crack, consider the material as failing.

15. Loss on Heating

15.1 From the representative specimen, cut two 300- by 150-mm [12- by 6-in.] test pieces as shown at K-1 and K-2 in Fig. 1. Weigh each specimen to the nearest 1 mg. Suspend both specimens 50 mm [2 in.] apart and parallel near the center of an oven maintained at $105 \pm 3^\circ\text{C}$ [$221 \pm 5^\circ\text{F}$]. Insert a thermometer in the oven to such a depth that its bulb will be in line with the center of the specimens. Keep them in the oven for $5 \text{ h} \pm 3 \text{ min}$; then remove them carefully and cool and

weigh each specimen. Calculate the average loss to the nearest 0.5 % of the specimen weights (including the detached comminuted surfacing, if any). Report this figure as the loss on heating. Subtract the percentage of moisture and report as the loss on heating exclusive of moisture.

EXAMINATION OF DESATURATED FELT OR FABRIC

16. Weight of Desaturated Felt or Fabric

16.1 Cut a 50 ± 0.5 -mm [$2 \pm \frac{1}{64}$ -in.] strip from the representative specimen as shown at H in Fig. 1. Measure its length to the nearest 1 mm [$\frac{1}{32}$ in.] and calculate its area to the nearest 500 mm^2 [1 in.^2]. Extract the test strip with 1,1,1-trichloroethane or other suitable solvent (see Note 4) in a suitable extractor (such as the one shown in Fig. 2) or centrifuge until washings are colorless. Dry the extracted specimen in the basket or thimble, first at room temperature in a ventilated fume chamber and then in a ventilated oven at $105 \pm 3^\circ\text{C}$ [$221 \pm 5^\circ\text{F}$], and cool in a desiccator. Remove the desaturated felt or fabric, brush off any adherent comminuted surfacing into the filter, and quickly weigh the felt or fabric to the nearest 0.1 g. Repeat the heating, cooling in desiccator, and weighing of the desaturated felt or fabric to constant weight. From the area of the specimens and the mass of the desaturated felt or fabric, calculate the mass per unit area of moisture-free desaturated felt or fabric. Report this mass to the nearest 5 g/m^2 [$0.1 \text{ lb}/100\text{ft}^2$] for felts and to the nearest 10 g/m^2 [$\frac{1}{2} \text{ oz/yd}^2$] for fabrics.

16.2 Where coal-tar saturant has been used (see Section 17), correct the moisture-free weight of the desaturated felt or fabric for carbonaceous matter retained mechanically in its interstices by multiplying by $(100-F)/100$, where F is the percentage of retained carbonaceous matter as determined in Section 17.

16.3 Recover the mineral matter in the filter medium by drying to constant weight in a vented oven at 104 to 110°C [220 to 230°F]. Calculate the entrapped mineral by subtracting the initial weight of the filter medium and record as adherent mineral matter and stabilizer.

NOTE 4—Coaltar-saturated felt cannot be thoroughly desaturated by any known means; only an approximate value may be obtained through desaturation. For coaltar products use Test Method D4072 or Test Method D4312.

17. Retained Carbonaceous Matter

17.1 Determine the carbonaceous matter derived from a coal-tar pitch saturant and retained by the desaturated fabric by means of the following colorimetric method. Please note that the results obtained for this determination are only an approximation.

17.1.1 Macerate by boiling in water about 15 g of an unsaturated fabric of the same general character as the one under examination, disintegrate with a rotary beater, and pick the fibers apart with needles. Filter the fibers through fine cloth and dry to constant weight at 107°C [225°F]. Accurately weigh a 1-g portion of the fiber into a flask and dilute to exactly 100 mL with distilled water at room temperature. Add about 50 g of

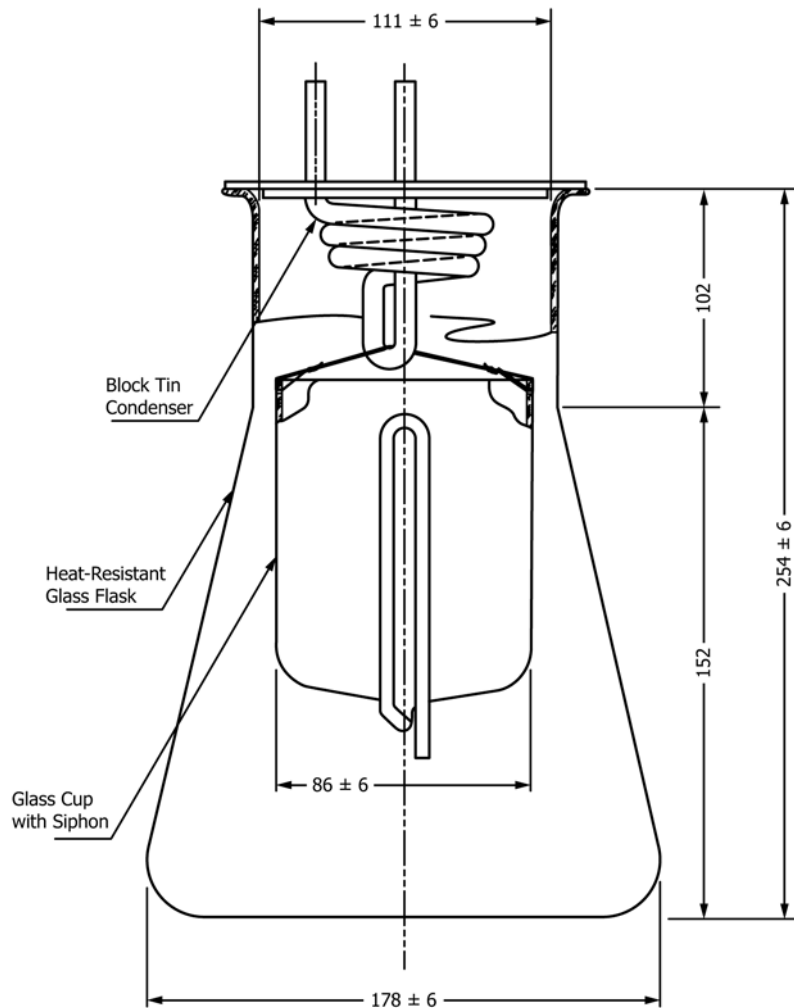

U.S. Customary Equivalents

mm	6	86	102	111	152	178	254
in.	¼	3⅝	4	4⅝	6	7	10

NOTE 1—All dimensions are in millimetres.

FIG. 2 Extraction Apparatus

glass beads and shake the contents of the flask vigorously until the fibers are reduced to a homogeneous pulp in uniform suspension.

17.1.2 Procure a distilled coal tar, having approximately 10 to 25 % of insoluble carbonaceous matter. Extract the carbonaceous matter with benzol until it is free of soluble matter, then dry to constant weight at 107°C [225°F]. Accurately weigh out 1 g of the purified carbonaceous matter and dilute to exactly 100 mL at room temperature with a starch solution of a consistency sufficient to carry the carbonaceous matter into temporary suspension. (A 12.5 weight % solution is recommended.)

17.1.3 Titrate the liquid carrying the fibers obtained as described in 17.1.2 with the suspension of carbonaceous matter, obtained as described in 17.1.2 and examine from time to time a field prepared from a drop of the well-agitated mixture, under a microscope at 100× until the color exactly

matches a field prepared from the desaturated fabric under examination (obtained as described in Section 16) when both are viewed side by side under identical conditions. The end point is fairly sharply defined. The buret reading gives directly the percentage of carbonaceous matter adhering to the moisture-free fabric under examination.

18. Total Comminuted Surfacing

18.1 Add the mass of adherent mineral matter, g/m² [lb/100 ft²] (Section 16) to the mass of detached comminuted surfacing (Section 11), and record as the total comminuted surfacing per area in g/m² [lb/100 ft² or oz/yd²].

19. Bituminous Saturant

19.1 Determine the mass of saturant by subtracting the sum of the masses of the moisture-free desaturated felt or fabric

(Section 16), the moisture (Section 12), and the total comminuted surfacing (Section 18), from the mass of the sample (Section 10) all expressed in grams per square metre, (or pounds per 100 square feet) for felts, or grams per square metre (or ounces per square yard) for fabrics. Report these masses, and calculate the ratio of the mass of the saturant to the mass of the desaturated moisture-free felt or fabric (Section 15) and report as the ratio of saturant to dry felt or fabric.

20. Thread Count of Fabrics

20.1 Test fabrics for number of threads per centimetre (or inch) in accordance with Test Methods D1910.

21. Thickness of Felts

21.1 Measure the thickness of the desaturated felt at 20 equally spaced spots along the length of the sample strip obtained in Section 16. In all other respects, follow Test Method D645/D645M.

22. Ash

22.1 If the mass of desaturated moisture-free felts or fabric (Section 16) is 25 g or less, ignite the whole desaturated

specimen. If it is greater than 25 g, cut the specimen into approximately 25-mm [1-in.] squares, mix them, and select about 25 g at random for ashing. Dry the ashing sample to constant weight at $105 \pm 3^\circ\text{C}$ [$221 \pm 5^\circ\text{F}$]. Weigh to the nearest 10 mg and ignite in a weighed porcelain or quartz dish or crucible until all carbon has been consumed. Cool in a desiccator, weigh, and record the weight as ash. Calculate the percentage on the basis of the desaturated moisture-free felt or fabric (Section 16) and report to the nearest 0.1 %.

23. Precision and Bias

23.1 No information can be presented on the precision and bias of Test Methods D146 because there is no evidence available to make a determination. It is unlikely that data will become available because of the volume of work necessary, the hazardous materials involved and the fact that the test methods have been successfully used in the industry for more than 15 years.

24. Keywords

24.1 bitumen-saturated felts; felts; roofing; waterproofing; woven fabrics

ASTM International takes no position respecting the validity of any patent rights asserted in connection with any item mentioned in this standard. Users of this standard are expressly advised that determination of the validity of any such patent rights, and the risk of infringement of such rights, are entirely their own responsibility.

This standard is subject to revision at any time by the responsible technical committee and must be reviewed every five years and if not revised, either reapproved or withdrawn. Your comments are invited either for revision of this standard or for additional standards and should be addressed to ASTM International Headquarters. Your comments will receive careful consideration at a meeting of the responsible technical committee, which you may attend. If you feel that your comments have not received a fair hearing you should make your views known to the ASTM Committee on Standards, at the address shown below.

This standard is copyrighted by ASTM International, 100 Barr Harbor Drive, PO Box C700, West Conshohocken, PA 19428-2959, United States. Individual reprints (single or multiple copies) of this standard may be obtained by contacting ASTM at the above address or at 610-832-9585 (phone), 610-832-9555 (fax), or service@astm.org (e-mail); or through the ASTM website (www.astm.org). Permission rights to photocopy the standard may also be secured from the Copyright Clearance Center, 222 Rosewood Drive, Danvers, MA 01923, Tel: (978) 646-2600; <http://www.copyright.com/>