



Designation: D1436 – 17

# Standard Test Methods for Application of Emulsion Floor Polishes to Substrates for Testing Purposes<sup>1</sup>

This standard is issued under the fixed designation D1436; the number immediately following the designation indicates the year of original adoption or, in the case of revision, the year of last revision. A number in parentheses indicates the year of last reapproval. A superscript epsilon ( $\epsilon$ ) indicates an editorial change since the last revision or reapproval.

## 1. Scope

1.1 These test methods cover procedures for application of emulsion floor polish films to suitable substrates for testing purposes. Five test methods are covered, as outlined in Section 3.

1.2 These procedures are limited to use on flat, rigid substrates mounted, if necessary, on a nonabsorbent backing.

1.3 The values stated in SI units are to be regarded as the standard. The values given in parentheses are provided for information only.

1.4 *This standard does not purport to address all of the safety concerns, if any, associated with its use. It is the responsibility of the user of this standard to establish appropriate safety and health practices and determine the applicability of regulatory limitations prior to use.*

1.5 *This international standard was developed in accordance with internationally recognized principles on standardization established in the Decision on Principles for the Development of International Standards, Guides and Recommendations issued by the World Trade Organization Technical Barriers to Trade (TBT) Committee.*

## 2. Significance and Use

2.1 All five of the test methods described will produce polish films from emulsion floor polishes which can be used for various performance tests. The choice of test method is left up to the individual laboratory.

## 3. Choice of Test Method

3.1 Under actual use conditions, the thickness of the dried film deposited from water emulsion floor polishes ranges from 0.03 mil to 0.4 mil. No one laboratory method has been found that will produce uniformly thick films throughout this range on all substrates. In many cases, the surface roughness and porosity of the substrate is of the same order of magnitude as

the thickness of the deposited films. Therefore, several alternative methods have been developed. Unless otherwise specified, the choice of method of application and substrate shall be mutually agreed upon by the purchaser and the seller. The characteristics of the five methods are as follows:

3.1.1 *Method A. Automatic Dip Coater*—This method produces thin films of excellent uniformity on the first coat with substrates of low or moderate porosity. Two- or three-coat applications may produce partial solubility of the earlier coats with consequent loss of uniformity.

3.1.2 *Method B. Hand Applicator*—This method simulates use conditions and produces thin films of satisfactory uniformity for many test purposes where the area of the test panel is small (304.8 by 304.8 mm (12 by 12 in.) or smaller). With large panels, considerable local nonuniformity of film thickness may result.

3.1.3 *Method C. Manual Dip Method*—This method results in wedge-shaped films, of moderate thickness, that are thicker at the bottom than at the top of the panel. This method is rapid and results in reproducible films in the center of the test panel which are useful for comparison tests and for tests involving the surface properties of the wax film.

3.1.4 *Method D. Blade Applicator*—This method merely spreads a known volume of emulsion over a known surface area. The uniformity of the resulting film depends on the flatness of the substrate, the surface tension of the emulsion, and the interfacial tension between the emulsion and the substrate. The method is satisfactory for producing thick to moderately thin films. Some practice and familiarity with the method are necessary to produce uniform thin films.

3.1.5 *Method E. Pour Surface*—This method covers pouring a small amount of polish over a tile held at a 45° angle and allowing it to flow uniformly down the tile and coating it. After the polish is poured and the bottom bead forms, it is wiped off and allowed to dry. The method is satisfactory for producing thick films for slip resistance testing.

## 4. Standard Conditions

4.1 The materials and apparatus shall be permitted to come to equilibrium in an atmosphere having a relative humidity of  $50 \pm 4\%$  and a temperature of  $23.8 \pm 1.1^\circ\text{C}$  ( $75 \pm 2^\circ\text{F}$ ).

<sup>1</sup> These test methods are under the jurisdiction of ASTM Committee D21 on Polishes and are the direct responsibility of Subcommittee D21.04 on Performance Tests.

Current edition approved March 1, 2017. Published April 2017. Originally approved in 1956. Last previous edition approved in 2015 as D1436 – 97(2015). DOI: 10.1520/D1436-17.

4.2 The application of the emulsion floor polish shall be carried out under the conditions specified in 4.1.

## TEST METHOD A. APPLICATION OF EMULSION FLOOR POLISH BY THE AUTOMATIC DIP COATER

### 5. Apparatus

5.1 *Automatic Dip Coater*—The automatic dip coater shall consist of a mechanism that will withdraw a panel from a tank of the emulsion at a predetermined rate. A suitable apparatus<sup>2</sup> consists of a constant-speed motor to which a pulley is attached. The diameter of the pulley is such that the cord and hook assembly attached to it will have a speed of 101.6 mm (4 in.)/min. The speed of withdrawal is kept uniform and is lower than that at which the coating drains. The test substrate must be withdrawn from the test solution entirely free of vibration.

5.2 *Dip Tank*, any tank with cover suitable for immersion of the substrate into the emulsion. The substrate must not touch the sides of the tank during withdrawal.

### 6. Procedure

6.1 Place the test substrate on the hook and lower it sufficiently into the dip tank to coat the panel to the desired area, using the cord. Place the other end of the cord around the pulley and give it one complete turn about the pulley. Attach the counterbalance and start the motor.

6.2 Following withdrawal from the emulsion, suspend the substrate on the hook or place it in a vertical position for 24 h under standard conditions.

## TEST METHOD B. APPLICATION OF EMULSION FLOOR POLISH WITH A HAND APPLICATOR

### 7. Apparatus

7.1 *Balance*, capacity 50 g, with an accuracy of  $\pm 0.05$  g.

7.2 *Pipet*, Mohr, 5-mL, graduated in 0.1-mL divisions.

7.3 *Applicator*, consisting of absorbent soft cheesecloth washed to remove sizing, cut into 51-mm (2-in.) strips of four-ply cloth, trimmed to weigh 0.60 g, and folded twice.

### 8. Procedure

8.1 1.8 mils of polish on a 12 by 12 in. OVCT<sup>3</sup> will usually equate to an approximate rate of 2100 ft<sup>2</sup>/gal.

8.2 Pipet the required amount of emulsion onto the center of the test panel. Place a cheesecloth strip over the solution and allow it to absorb the emulsion. Distribute the emulsion evenly over the surface; then draw the cheesecloth downward once in separate strokes until the entire panel is crossed with no more pressure than is exerted by the weight of the hand. Immediately place the used cheesecloth in a ground-glass stoppered, tared

weighing bottle, weigh, and calculate and record the net weight of the used wet applicator.

8.3 To ensure a constant film thickness, the weight of the spent applicators should not vary by more than 0.15 g. If the weight variation exceeds 0.15 g, the test panel should be discarded.

8.4 Dry the coated substrates for 18 to 24 h under standard-conditions before testing.

### 9. Calculation

9.1 Assuming 1 mL of the emulsion as equal to 1 g, calculate the weight of emulsion applied to the test panel as follows:

$$\text{Weight of emulsion on test panel, g} = (A + 0.60) - B \quad (1)$$

where:

$A$  = total weight of emulsion applied on applicator and test panel, g, and

$B$  = weight of used wet applicator, g.

## TEST METHOD C. APPLICATION OF EMULSION FLOOR POLISH FILMS BY MANUAL DIP

### 10. Apparatus

10.1 *Dip Tank*, any tank with cover suitable for immersion of the substrate into the emulsion.

### 11. Procedure

11.1 Immerse the substrate completely into the dip tank containing the emulsion to be tested for 1 min. Then withdraw the substrate as quickly as possible without touching the sides of the vessel, and place in a vertical position and allow to dry under standard conditions for 24 h.

11.2 If a two-coat application is required, reverse the substrate in drain drying so as to equalize the film thickness.

## TEST METHOD D. APPLICATION OF EMULSION FLOOR POLISH FILM BY THE BLADE APPLICATOR

### 12. Apparatus

12.1 *Blade Applicator*, 51-mm (2-in.) wide, sharp-edge, metal or plastic blade with a clearance of 0.203 mm (0.008 in.) (see Fig. 1).

12.2 *Pipet*, Mohr, 5-mL with 0.1-mL graduations.

### 13. Procedure

13.1 Drop the proper quantity (see Note 1) of the emulsion sample onto the substrate that has been carefully leveled. Touch the center of the doctor blade applicator to the emulsion. Move the applicator from side to side so that the emulsion covers the entire sharp edge. Spread the emulsion rapidly with the applicator held vertically over a length of 4 in. (101.6 mm) by moving the applicator back and forth to produce a uniform coat 51 by 101.6 mm (2 by 4 in.), removing the applicator at the center of a stroke.

NOTE 1—The approximate relationship of quantity of floor polish

<sup>2</sup> On this equipment, the largest spindle is used.

<sup>3</sup> OVCT tile may be obtained through Armstrong Flooring from various home improvement stores. The following Armstrong tile substrates have been found to perform adequately for this test method: Armstrong Excelon Feature Tile: Black (56790), [http://www.armstrong.com/commflooringna/product\\_details\\_toolbox\\_magnify.jsp?item\\_id=47394](http://www.armstrong.com/commflooringna/product_details_toolbox_magnify.jsp?item_id=47394).

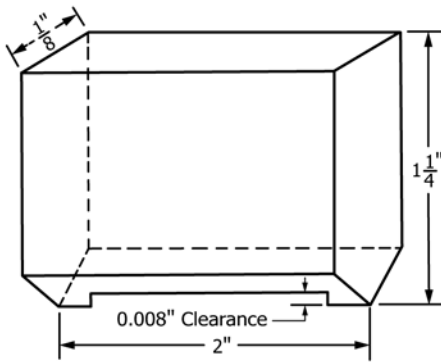

Metric Equivalents

in.	0.008	1/8	1 1/4	2
mm	0.203	3	32	51

FIG. 1 Blade Applicator

applied to floor area covered is as follows:

- 0.1 mL over 8 in.<sup>2</sup> ≈ 2103 ft<sup>2</sup>/gal
- 0.2 mL over 8 in.<sup>2</sup> ≈ 1051 ft<sup>2</sup>/gal
- 0.4 mL over 8 in.<sup>2</sup> ≈ 526 ft<sup>2</sup>/gal

13.2 Allow the resultant film to dry 24 h under standard conditions.

## TEST METHOD E. APPLICATION OF EMULSION FLOOR POLISH BY POUR SURFACE

### 14. Procedure

14.1 Pour a small quantity (10 to 15 mL) of polish over the substrate which is held at a 45° angle. After pouring the polish on the surface and it is uniformly distributed, wipe off the bead formed at the bottom and allow to dry.

14.2 Allow the resultant film to dry 24 h under standard conditions.

### 15. Precision and Bias

15.1 Each test method will produce replicate films from a polish sample. The same application method should be used throughout a test series in order to obtain film uniformity.

15.2 Since there is no accepted reference material suitable for this test method for measuring the application of emulsion floor polishes to substrates for testing purposes, bias has not been determined.

### 16. Keywords

16.1 application; applicator; blade applicator; cheesecloth; dip coater; emulsion; film; polishes; substrate; wax

*ASTM International takes no position respecting the validity of any patent rights asserted in connection with any item mentioned in this standard. Users of this standard are expressly advised that determination of the validity of any such patent rights, and the risk of infringement of such rights, are entirely their own responsibility.*

*This standard is subject to revision at any time by the responsible technical committee and must be reviewed every five years and if not revised, either reapproved or withdrawn. Your comments are invited either for revision of this standard or for additional standards and should be addressed to ASTM International Headquarters. Your comments will receive careful consideration at a meeting of the responsible technical committee, which you may attend. If you feel that your comments have not received a fair hearing you should make your views known to the ASTM Committee on Standards, at the address shown below.*

*This standard is copyrighted by ASTM International, 100 Barr Harbor Drive, PO Box C700, West Conshohocken, PA 19428-2959, United States. Individual reprints (single or multiple copies) of this standard may be obtained by contacting ASTM at the above address or at 610-832-9585 (phone), 610-832-9555 (fax), or service@astm.org (e-mail); or through the ASTM website (www.astm.org). Permission rights to photocopy the standard may also be secured from the Copyright Clearance Center, 222 Rosewood Drive, Danvers, MA 01923, Tel: (978) 646-2600; http://www.copyright.com/*