



Standard Test Methods for Small Clear Specimens of Timber¹

This standard is issued under the fixed designation D143; the number immediately following the designation indicates the year of original adoption or, in the case of revision, the year of last revision. A number in parentheses indicates the year of last reappraisal. A superscript epsilon (ϵ) indicates an editorial change since the last revision or reappraisal.

INTRODUCTION

The need to classify wood species by evaluating the physical and mechanical properties of small clear specimens has always existed. Because of the great variety of species, variability of the material, continually changing conditions of supply, many factors affecting test results, and ease of comparing variables, the need will undoubtedly continue to exist.

In the preparation of these methods for testing small clear specimens, consideration was given both to the desirability of adopting test methods that would yield results comparable to those already available and to the possibility of embodying such improvements as experience has shown desirable. In view of the many thousands of tests made under a single comprehensive plan by the U.S. Forest Service, the former Forest Products Laboratories of Canada (now FP Innovations), and other similar organizations, these test methods naturally conform closely to the methods used by those institutions. These test methods are the outgrowth of a study of both American and European experience and methods. The general adoption of these test methods will tend toward a world-wide unification of results, permitting an interchange and correlation of data, and establishing the basis for a cumulative body of fundamental information on the timber species of the world.

Descriptions of some of the strength tests refer to primary methods and secondary methods. Primary methods provide for specimens of 2 by 2-in. (50 by 50-mm) cross section. This size of specimen has been extensively used for the evaluation of various mechanical and physical properties of different species of wood, and a large number of data based on this primary method have been obtained and published.

The 2 by 2-in. (50 by 50-mm) size has the advantage in that it embraces a number of growth rings, is less influenced by earlywood and latewood differences than smaller size specimens, and is large enough to represent a considerable portion of the sampled material. It is advisable to use primary method specimens wherever possible. There are circumstances, however, when it is difficult or impossible to obtain clear specimens of 2 by 2-in. cross section having the required 30 in. (760 mm) length for static bending tests. With the increasing incidence of smaller second growth trees, and the desirability in certain situations to evaluate a material which is too small to provide a 2 by 2-in. cross section, a secondary method which utilizes a 1 by 1-in. (25 by 25-mm) cross section has been included. This cross section is established for compression parallel to grain and static bending tests, while the 2 by 2-in. cross section is retained for impact bending, compression perpendicular to grain, hardness, shear parallel to grain, cleavage, and tension perpendicular to grain. Toughness and tension parallel to grain are special tests using specimens of smaller cross section.

The user is cautioned that test results between two different sizes of specimens are not necessarily directly comparable. Guidance on the effect of specimen size on a property being evaluated is beyond the scope of these test methods and should be sought elsewhere.

Where the application, measurement, or recording of load and deflection can be accomplished using electronic equipment and computerized apparatus, such devices are encouraged, providing they do not lower the standard of accuracy and reliability available with basic mechanical equipment.

1. Scope

1.1 These test methods cover the determination of various strength and related properties of wood by testing small clear specimens.

1.1.1 These test methods represent procedures for evaluating the different mechanical and physical properties, controlling factors such as specimen size, moisture content, temperature, and rate of loading.

1.1.2 Sampling and collection of material is discussed in Practice [D5536](#). Sample data, computation sheets, and cards have been incorporated, which were of assistance to the investigator in systematizing records.

1.1.3 The values stated in inch-pound units are to be regarded as the standard. The values given in parentheses are mathematical conversions to SI units that are provided for information only and are not considered standard. When a weight is prescribed, the basic inch-pound unit of weight (lbf) and the basic SI unit of mass (Kg) are cited.

1.2 The procedures for the various tests appear in the following order:

	Sections
Photographs of Specimens	5
Control of Moisture Content and Temperature	6
Record of Heartwood and Sapwood	7
Static Bending	8
Compression Parallel to Grain	9
Impact Bending	10
Toughness	11
Compression Perpendicular to Grain	12
Hardness	13
Shear Parallel to Grain	14
Cleavage	15
Tension Parallel to Grain	16
Tension Perpendicular to Grain	17
Nail Withdrawal	18
Specific Gravity and Shrinkage in Volume	19
Radial and Tangential Shrinkage	20
Moisture Determination	21
Permissible Variations	22
Calibration	23

1.3 *This standard does not purport to address all of the safety concerns, if any, associated with its use. It is the responsibility of the user of this standard to establish appropriate safety and health practices and determine the applicability of regulatory limitations prior to use.*

2. Referenced Documents

2.1 *ASTM Standards:*²

[D198 Test Methods of Static Tests of Lumber in Structural Sizes](#)

[D2395 Test Methods for Density and Specific Gravity \(Relative Density\) of Wood and Wood-Based Materials](#)

[D3043 Test Methods for Structural Panels in Flexure](#)

¹ These test methods are under the jurisdiction of ASTM Committee [D07](#) on Wood and are the direct responsibility of Subcommittee [D07.01](#) on Fundamental Test Methods and Properties.

Current edition approved Feb. 1, 2014. Published April 2014. Originally approved in 1922. Last previous edition approved in 2009 as [D143 – 09](#). DOI: 10.1520/D0143-14.

² For referenced ASTM standards, visit the ASTM website, www.astm.org, or contact ASTM Customer Service at service@astm.org. For *Annual Book of ASTM Standards* volume information, refer to the standard's Document Summary page on the ASTM website.

- [D3500 Test Methods for Structural Panels in Tension](#)
- [D4442 Test Methods for Direct Moisture Content Measurement of Wood and Wood-Based Materials](#)
- [D4761 Test Methods for Mechanical Properties of Lumber and Wood-Base Structural Material](#)
- [D5536 Practice for Sampling Forest Trees for Determination of Clear Wood Properties](#)
- [E4 Practices for Force Verification of Testing Machines](#)
- [E2309 Practices for Verification of Displacement Measuring Systems and Devices Used in Material Testing Machines](#)

3. Summary of Test Methods

3.1 The mechanical tests are static bending, compression parallel to grain, impact bending toughness, compression perpendicular to grain, hardness, shear parallel to grain ([Note 1](#)), cleavage, tension parallel to grain, tension-perpendicular-to-grain, and nail-withdrawal tests. These tests may be made on both green and air-dry material as specified in these test methods. In addition, test methods for evaluating such physical properties as specific gravity, shrinkage in volume, radial shrinkage, and tangential shrinkage are presented.

NOTE 1—The test for shearing strength perpendicular to the grain (sometimes termed “vertical shear”) is not included as one of the principal mechanical tests since in such a test the strength is limited by the shearing resistance parallel to the grain.

4. Significance and Use

4.1 These test methods cover tests on small clear specimens of wood that are made to provide the following:

4.1.1 Data for comparing the mechanical properties of various species,

4.1.2 Data for the establishment of correct strength functions, which in conjunction with results of tests of timbers in structural sizes (see Test Methods [D198](#) and Test Methods [D4761](#)), afford a basis for establishing allowable stresses, and

4.1.3 Data to determine the influence on the mechanical properties of such factors as density, locality of growth, position in cross section, height of timber in the tree, change of properties with seasoning or treatment with chemicals, and change from sapwood to heartwood.

5. Photographs of Specimens

5.1 Four of the static bending specimens from each species shall be selected for photographing, as follows: two average growth, one fast growth, and one slow growth. These specimens shall be photographed in cross section and on the radial and tangential surfaces. [Fig. 1](#) is a typical photograph of a cross section of 2 by 2-in. (50 by 50-mm) test specimens, and [Fig. 2](#) is the tangential surface of such specimens.

6. Control of Moisture Content and Temperature

6.1 In recognition of the significant influence of temperature and moisture content on the strength of wood, it is highly desirable that these factors be controlled to ensure comparable test results.

6.2 *Control of Moisture Content*—Specimens for the test in the air-dry condition shall be dried to approximately constant weight before test. Should any changes in moisture content

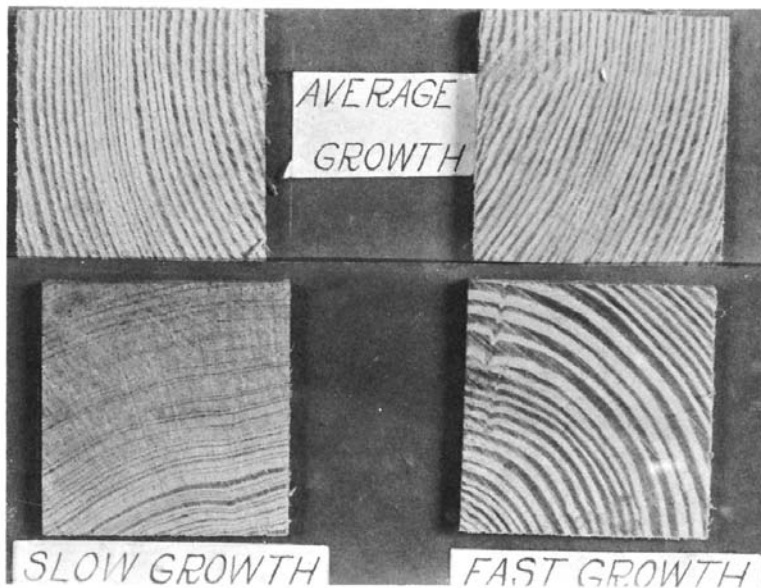

FIG. 1 Cross Sections of Bending Specimens Showing Different Rates of Growth of Longleaf Pine (2 by 2-in. (50 by 50-mm) Specimens)



FIG. 2 Tangential Surfaces of Bending Specimens of Different Rates of Growth of Jeffrey Pine 2 by 2-in. (50 by 50 by 760-mm) Specimens

occur during final preparation of specimens, the specimens shall be reconditioned to constant weight before test. Tests shall be carried out in such manner that large changes in moisture content will not occur. To prevent such changes, it is desirable that the testing room and rooms for preparation of test specimens have some means of humidity control.

6.3 *Control of Temperature*—Temperature and relative humidity together affect wood strength by fixing its equilibrium moisture content. The mechanical properties of wood are also affected by temperature alone. When tested, the specimens shall be at a temperature of $68 \pm 6^\circ\text{F}$ ($20 \pm 3^\circ\text{C}$). The temperature at the time of test shall in all instances be recorded as a specific part of the test record.

7. Record of Heartwood and Sapwood

7.1 *Proportion of Sapwood*—The estimated proportion of sapwood present should be recorded for each test specimen.

8. Static Bending

8.1 *Size of Specimens*—The static bending tests shall be made on 2 by 2 by 30 in. (50 by 50 by 760 mm) primary method specimens or 1 by 1 by 16 in. (25 by 25 by 410 mm) secondary method specimens. The actual height and width at the center and the length shall be measured (see 22.2).

8.2 *Loading Span and Supports*—Use center loading and a span length of 28 in. (710 mm) for the primary method and 14 in. (360 mm) for the secondary method. These spans were established in order to maintain a minimum span-to-depth ratio of 14. Both supporting knife edges shall be provided with bearing plates and rollers of such thickness that the distance from the point of support to the central plane is not greater than the depth of the specimen (Fig. 3). The knife edges shall be adjustable laterally to permit adjustment for slight twist in the specimen (Note 2).

minimum, the load-deflection curve shall be recorded at 0.10 in. (2.5 mm) intervals and also after abrupt changes in load.

8.6.4 The load and deflection of first failure, the maximum load, and points of sudden change shall be read and shown on the curve sheet (Note 4) although they may not occur at one of the regular load or deflection increments.

NOTE 4—See Fig. 5 for a sample static bending data sheet form.

8.7 Description of Static Bending Failures—Static bending (flexural) failures shall be classified in accordance with the appearance of the fractured surface and the manner in which the failure develops (Fig. 6). The fractured surfaces may be

roughly divided into “brash” and “fibrous”, the term “brash” indicating abrupt failure and “fibrous” indicating a fracture showing splinters.

8.8 Weight and Moisture Content—The specimen shall be weighed immediately before test, and after the test a moisture section approximately 1 in. (25 mm) in length shall be cut from the specimen near the point of failure (see 21.1 and 22.1).

9. Compression Parallel to Grain

9.1 Size of Specimens—The compression-parallel-to-grain tests shall be made on 2 by 2 by 8 in. (50 by 50 by 200 mm)

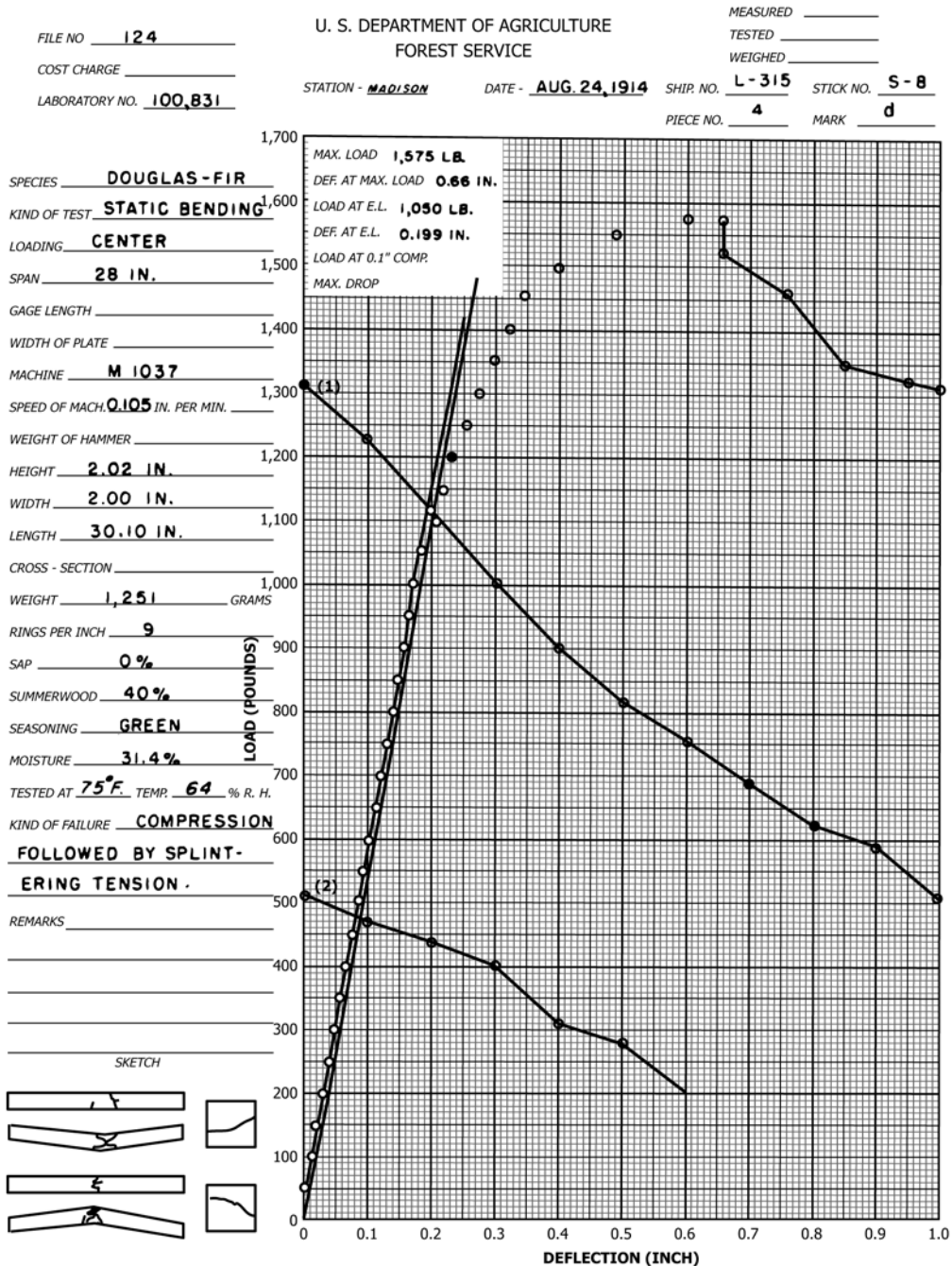
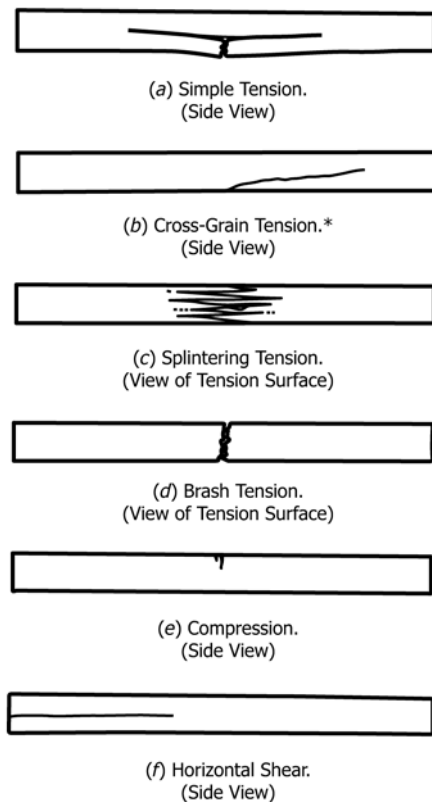

FIG. 5 Sample Data Sheet for Static Bending Test



NOTE 1—The term “cross grain” shall be considered to include all deviations of grain from the direction of the longitudinal axis or longitudinal edges of the specimen. It should be noted that spiral grain may be present even to a serious extent without being evident from a casual observation.

NOTE 2—The presence of cross grain having a slope that deviates more than 1 in 20 from the longitudinal edges of the specimen shall be cause for culling the test.

FIG. 6 Types of Failures in Static Bending

primary method specimens, or 1 by 1 by 4 in. (25 by 25 by 100 mm) secondary method specimens. The actual cross-sectional dimensions and the length shall be measured (see 22.2).

9.2 *End Surfaces Parallel*—Special care shall be used in preparing the compression-parallel-to-grain test specimens to ensure that the end grain surfaces will be parallel to each other and at right angles to the longitudinal axis. At least one platen of the testing machine shall be equipped with a spherical bearing to obtain uniform distribution of load over the ends of the specimen.

9.3 *Speed of Testing*—The load shall be applied continuously throughout the test at a rate of motion of the movable crosshead of 0.003 in./in. (mm/mm) of nominal specimen length/min (see 22.3).

9.4 *Load-Compression Curves:*

9.4.1 Load-compression curves shall be taken over a central gage length not exceeding 6 in. (150 mm) for primary method specimens, and 2 in. (50 mm) for secondary method specimens. Load-compression readings shall be continued until the proportional limit is well passed, as indicated by the curve (Note 5).

NOTE 5—See Fig. 7 for a sample compression-parallel-to-grain data sheet form.

9.4.2 Deformations shall be recorded using displacement measurement devices that are capable of a Class A rating when evaluated in accordance with Practice E2309.

9.4.3 Figs. 8 and 9 illustrate two types of compressometers that have been found satisfactory for wood testing. Similar apparatus is available for measurements of compression over a 2 in. (50 mm) gage length.

9.5 *Position of Test Failures*—In order to obtain satisfactory and uniform results, it is necessary that the failures be made to develop in the body of the specimen. With specimens of uniform cross section, this result can best be obtained when the ends are at a very slightly lower moisture content than the body. With green material, it will usually suffice to close-pile the specimens, cover the body with a damp cloth, and expose the ends for a short time. For dry material, it may sometimes be advisable to pile the specimens in a similar manner and place them in a desiccator, should the failures in test indicate that a slight end-drying is necessary.

9.6 *Descriptions of Compression Failures*—Compression failures shall be classified in accordance with the appearance of the fractured surface (Fig. 10). In case two or more kinds of failures develop, all shall be described in the order of their occurrence; for example, shearing followed by brooming. The failure shall also be sketched in its proper position on the data sheet.

9.7 *Weight and Moisture Content*—See 8.8.

9.8 *Ring and Latewood Measurement*—When practicable, the number of rings per inch (average ring width in millimetres) and the proportion of summerwood shall be measured over a representative inch (centimetre) of cross section of the test specimen. In determining the proportion of summerwood, it is essential that the end surface be prepared so as to permit accurate latewood measurement. When the fibers are broomed over at the ends from sawing, a light sanding, planing, or similar treatment of the ends is recommended.

10. Impact Bending

10.1 *Size of Specimens*—The impact bending tests shall be made on 2 by 2 by 30 in. (50 by 50 by 760 mm) specimens. The actual height and width at the center and the length shall be measured (see 22.2).

10.2 *Loading and Span*—Use center loading and a span length of 28 in. (710 mm).

10.3 *Bearing Block*—A metal tup of curvature corresponding to the bearing block shown in Fig. 4 shall be used in applying the load.

10.4 *Placement of Growth Rings*—The specimen shall be placed so that the load will be applied through the bearing block to the tangential surface nearest the pith.

10.5 *Procedure*—Make the tests by increment drops in a Hatt-Turner or similar impact machine (see Fig. 11). The first drop shall be 1 in. (25 mm), after which increase the drops by 1 in. increments until a height of 10 in. (250 mm) is reached.

FILE NO. 124
 COST CHARGE _____
 LABORATORY NO. 871,902

U. S. DEPARTMENT OF AGRICULTURE
 FOREST SERVICE

STATION - MADISON DATE - NOV. 5, 1943 SHIP. NO. 1590 STICK NO. S-5
 PIECE NO. 5 MARK d

MEASURED _____
 TESTED _____
 WEIGHED _____

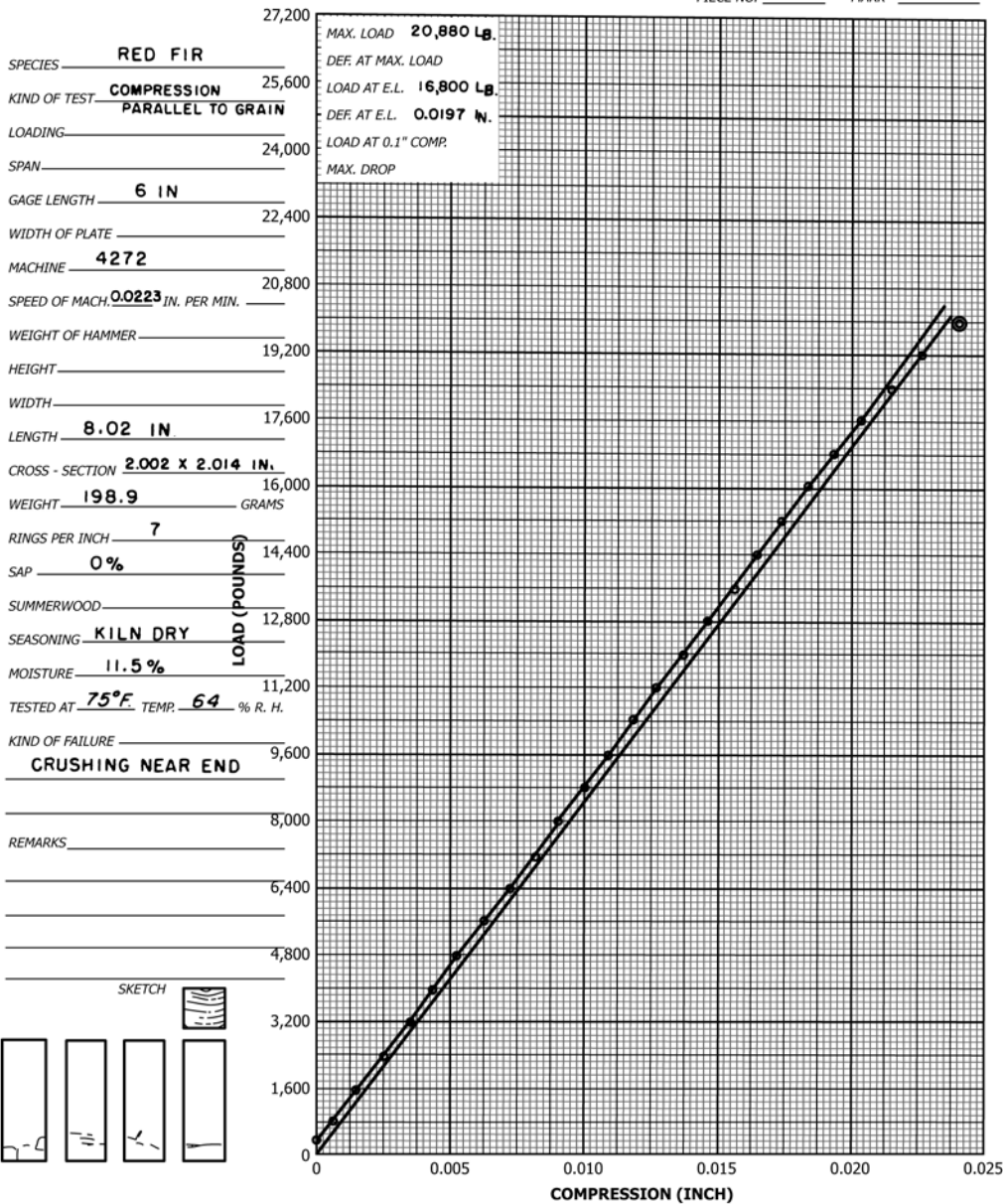

FIG. 7 Sample Data Sheet for Compression-Parallel-to-Grain Test

Then use a 2 in. (50 mm) increment until complete failure occurs or a 6 in. (150 mm) deflection is reached.

10.6 *Weight of Hammer*—A50 lbf (22.5 kg) hammer shall be used when, with drops up to the capacity of the machine (about 68 in. (1.7 m) for the small Hatt-Turner impact machine), it is practically certain that complete failure or a 6 in. (150 mm) deflection will result for all specimens of a species. For all other cases, a 100 lbf (45 kg) hammer shall be used.

10.7 *Deflection Records*—When desired, graphical drum records (Note 6) giving the deflection for each drop and the set, if any, shall be made until the first failure occurs. This record

will also afford data from which the exact height of drop can be scaled for at least the first four falls.

NOTE 6—See Fig. 12 for a sample drum record.

10.8 *Drop Causing Failure*—The height of drop causing either complete failure or a 6 in. (150 mm) deflection shall be observed for each specimen.

10.9 *Description of Failure*—The failure shall be sketched on the data sheet (Note 7) and described in accordance with the directions for static bending in 8.7.

NOTE 7—See Fig. 13 for a sample impact bending data sheet form. Fig.

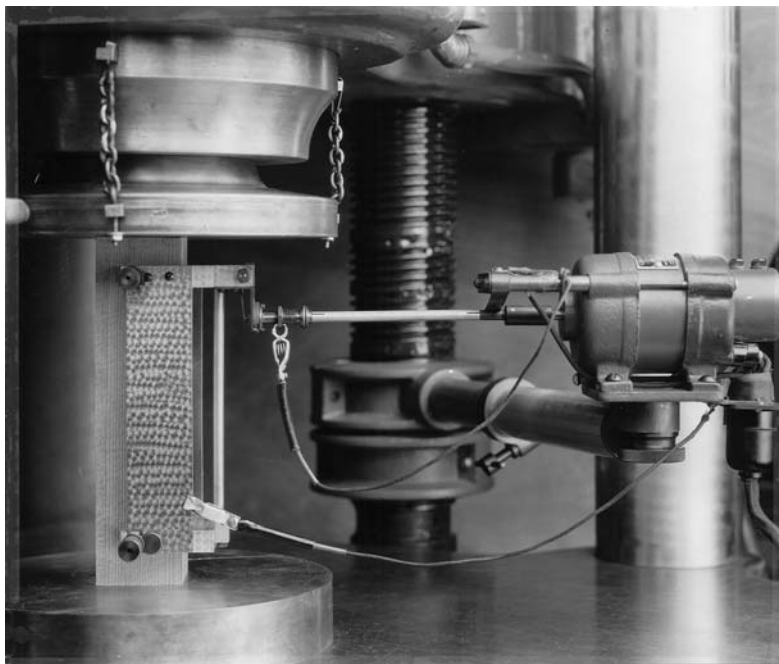

FIG. 8 Compression-Parallel-to-Grain Test Assembly Using an Automatic Type of Compressometer to Measure Deformations (The wire in the lower right-hand corner connects the compressometer with the recording unit.)

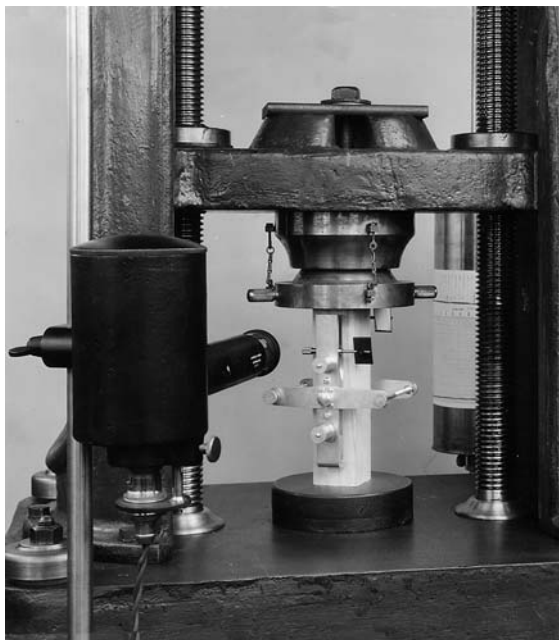

FIG. 9 Compression-Parallel-to-Grain Test Assembly Showing Method of Measuring Deformations by Means of Roller-Type Compressometer

one procedure is superior to another, or whether the results by the different test methods can be directly correlated. If the Toughness machine is used, the following procedure has been found satisfactory. To aid in standardization and to facilitate comparisons, the size of the toughness specimen has been made equal to that accepted internationally.

11.2 *Size of Specimen*—The toughness tests shall be made on 0.79 by 0.79 by 11 in. (20 by 20 by 280 mm) specimens. The actual height and width at the center and the length shall be measured (see 22.2).

11.3 *Loading and Span*—Center loading and a span length of 9.47 in. (240 mm) shall be used. The load shall be applied to a radial or tangential surface on alternate specimens.

11.4 *Bearing Block*—An aluminum tup (Fig. 15) having a radius of $\frac{3}{4}$ in. (19 mm) shall be used in applying the load.

11.5 *Apparatus and Procedure*—Make the tests in a pendulum type toughness machine (Note 8) (See Fig. 15). Adjust the machine before test so that the pendulum hangs vertically, and adjust it to compensate for friction. Adjust the cable so that the load is applied to the specimen when the pendulum swings to 15° from the vertical, so as to produce complete failure by the time the downward swing is completed. Choose the weight position and initial angle (30, 45, or 60°) of the pendulum, so that complete failure of the specimen is obtained on one drop. Most satisfactory results are obtained when the difference between the initial and final angle is at least 10° .

NOTE 8—Many pendulum-type toughness machines are based on a design developed and used at the USDA Forest Products Laboratory in Madison, Wisconsin.

11.6 *Calculation*—The initial and final angle shall be read to the nearest 0.1° by means of the vernier (Fig. 15) attached to the machine (Note 9).

14 shows a sample data and computation card.

10.10 *Weight and Moisture Content*—See 8.8.

11. Toughness

11.1 A single-blow impact test on a small specimen is recognized as a valuable and desirable test. Several types of machines such as the Toughness, Izod and Amsler have been used, but insufficient information is available to decide whether

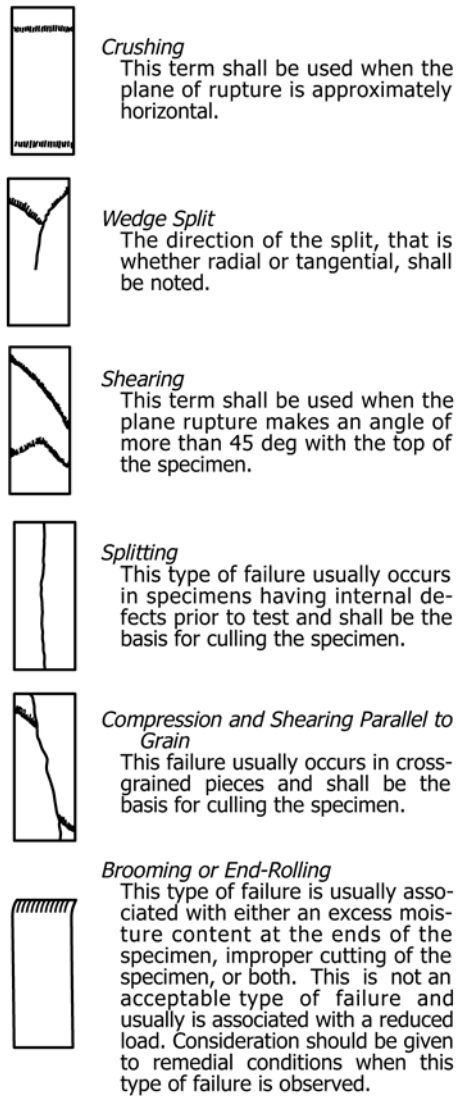

FIG. 10 Types of Failures in Compression

NOTE 9—See Fig. 16 for sample data and computation sheet for the toughness test.

The toughness shall then be calculated as follows:

$$T = wL(\cos A_2 - \cos A_1) \quad (1)$$

where:

- T = toughness (work per specimen, in. · lbf (Nm)),
- w = weight of pendulum, lbf (N),
- L = distance from center of the supporting axis to center of gravity of the pendulum, in. (m),
- A_1 = initial angle (Note 10), degrees, and
- A_2 = final angle the pendulum makes with the vertical after failure of the test specimen, degrees.

NOTE 10—Since friction is compensated for in the machine adjustment, the initial angle may be regarded as exactly 30, 45, or 60°, as the case may be.

11.7 *Weight and Moisture Content*—The specimen shall be weighed immediately before test, and after test a moisture section approximately 2 in. (50 mm) in length shall be cut from the specimen near the failure (see 21.1 and 22.1).

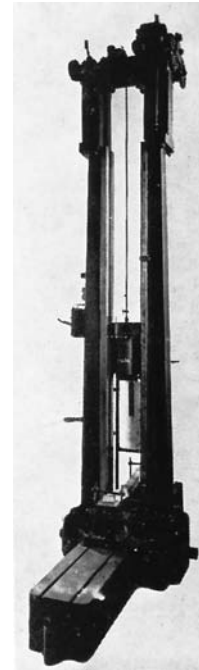

FIG. 11 Hatt-Turner Impact Machine, Illustrating Test Method of Conducting Impact Bending Test

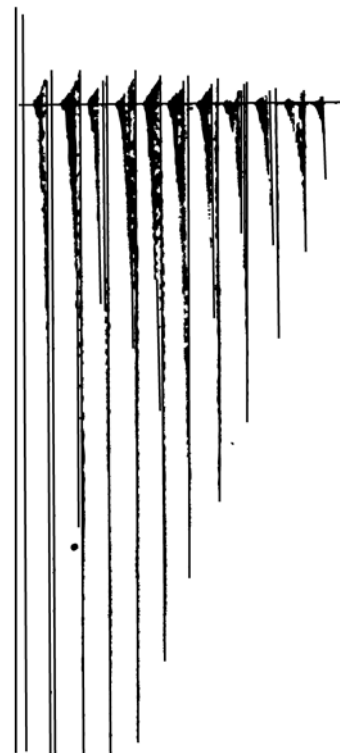

FIG. 12 Sample Drum Record of Impact Bending Test

12. Compression Perpendicular to Grain

12.1 *Size of Specimens*—The compression-perpendicular-to-grain tests shall be made on 2 by 2 by 6 in. (50 by 50 by 150 mm) specimens. The actual height, width, and length shall be measured (see 22.2).

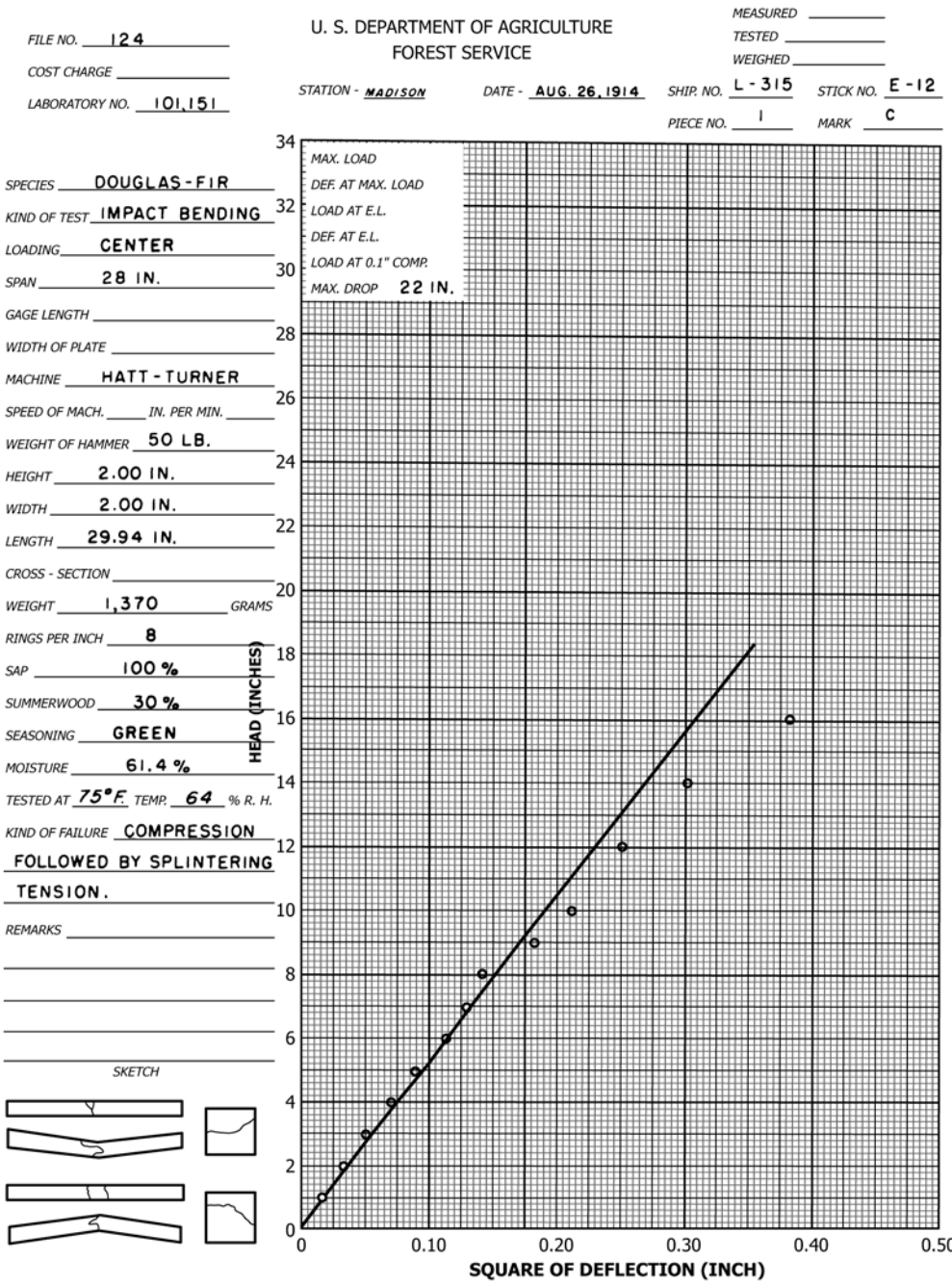

FIG. 13 Sample Data Sheet for Impact Bending Test

12.2 *Loading*—The load shall be applied through a metal bearing plate 2 in. (50 mm) in width, placed across the upper surface of the specimen at equal distances from the ends and at right angles to the length (Fig. 17). The actual width of the bearing plate shall be measured (see 22.2).

12.3 *Placement of Growth Rings*—The specimens shall be placed so that the load will be applied through the bearing plate to a radial surface.

12.4 *Speed of Testing*—The load shall be applied continuously throughout the test at a rate of motion of the movable crosshead of 0.012 in. (0.305 mm)/min (see 22.3).

12.5 *Load-Compression Curves:*

12.5.1 Load-compression curves (Note 11) shall be taken for all specimens up to 0.1 in. (2.5 mm) compression, after which the test shall be discontinued. Compression shall be measured between the loading surfaces.

NOTE 11—See Fig. 18 for a sample compression-perpendicular-to-grain data sheet form.

12.5.2 Deformations shall be recorded using displacement measurement devices that are capable of at least a Class A rating when evaluated in accordance with Practice E2309.

IMPACT BENDING										
L-315 (Ship No.)		F-12 (Stick No.)		Station MADISON		Date Aug. 20, 1914		1011.1 (Lab. No.)		
1 (Piece No.)		C (Mark)						124 (Project No.)		
Species Douglas Fir				Grade Clear		Seasoning Green				
Rings 8		Sap 100		% Summerwood 30		% Moisture 61.4				
Hammer 50 lbs.		Span 28 in.		Length 29.94 in.		Height 2.00 in.		Width 2.00 in.		
Weight 1370 g.										
DROP No.	HEAD	DEV.	DER ²	SET.	DROP No.	HEAD	DEV.	DER ²	SET.	Sp. Gr. (at test)
1	1.0	0.13	0.017		11	12.0	0.50	0.250		0.698
2	2.0	0.18	0.032		12	14.0	0.55	0.302		Sp. Gr. (oven dry) 0.432
3	3.0	0.22	0.048		13	16.0	0.62	0.384		F. S. at E. L. 10 610
4	4.0	0.26	0.068		14	18.0	0.67	0.593		M. of E. 1776
5	5.0	0.30	0.090		15					E. Resil. 3.51
6	6.0	0.34	0.116		16					Max: Drop, 22 in.
7	7.0	0.36	0.130		17					d, 0.010
8	8.0	0.38	0.144		18					H 7.88
9	9.0	0.43	0.185		19					Δ 0.39
10	10.0	0.46	0.212		20					

Failure: Compression Followed by Splintering Tension.

FIG. 14 Sample Data and Computation Card for Impact Bending Test

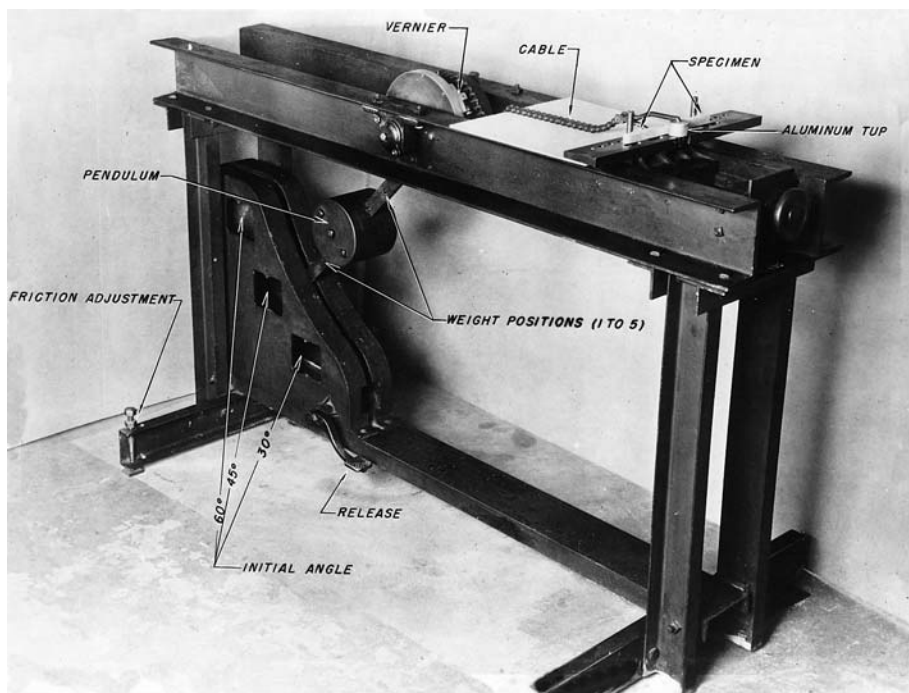

FIG. 15 Toughness Test Assembly

12.6 *Weight and Moisture Content*—The specimen shall be weighed immediately before test, and after test a moisture section approximately 1 in. (25 mm) in length shall be cut adjacent to the part under load (see 21.1 and 22.1).

13. Hardness

13.1 *Size of Specimens*—The hardness tests shall be made on 2 by 2 by 6 in. (50 by 50 by 150 mm) specimens. The actual cross-sectional dimensions and length shall be measured (see 22.2).

13.2 *Procedure*—Use the modified ball test with a “ball” 0.444 in. (11.3 mm) in diameter for determining hardness (Fig. 19). The projected area of the ball on the test specimen is 1 cm². Record the load at which the ball has penetrated to one

half its diameter, as determined by an electric circuit indicator or by the tightening of the collar against the specimen.

13.3 *Number of Penetrations*—Two penetrations shall be made on a tangential surface, two on a radial surface, and one on each end. The choice between the two radial and between the two tangential surfaces shall be such as to give a fair average of the piece. The penetrations shall be far enough from the edge to prevent splitting or chipping (Note 12).

NOTE 12—See Fig. 20 for a sample data and computation sheet for hardness test.

13.4 *Speed of Testing*—The load shall be applied continuously throughout the test at a rate of motion of the movable crosshead of 0.25 in. (6 mm/min) (see 22.3).

TOUGHNESS

STATION - Madison
 SPECIES PACIFIC SILVER FIR SHIPMENT NO. 1,651
 PROJECT Str. 1L SEASONING GREEN MEASURED BY _____
 COST CHARGE 01-3-005 SPAN 9.47 IN. WEIGHED BY _____
 LABORATORY NOS. 268,779A-806A MACHINE NO. 4,715 TESTED BY _____
 DATE FEB. 1, 1950 TEMP. 75 °F. REL. HUMIDITY 64%

STICK NO.	LAB. NO.	DIMENSIONS L" x H" x W"	WEIGHT GM.	MOIST. %	SP. GR.	POSITION OF RINGS *		WEIGHT	INITIAL ANGLE °	FINAL ANGLE		TOUGHNESS INCH - POUNDS	REMARKS
						RAD.	TANG.			°	'		
									3	45			
<u>22E-3-d-1</u>	<u>785A</u>	<u>11.02 X .794 X .797</u>	<u>53.80</u>	<u>32.0</u>	<u>.357</u>		<u>✓</u>			<u>32</u>	<u>30</u>	<u>143.8</u>	
<u>2</u>	<u>786A</u>	<u>11.02 X .789 X .790</u>	<u>52.54</u>	<u>31.8</u>	<u>.354</u>		<u>✓</u>			<u>31</u>	<u>56</u>	<u>149.7</u>	
<u>22E-5-C-1</u>	<u>787A</u>	<u>11.02 X .792 X .795</u>	<u>53.56</u>	<u>35.7</u>	<u>.347</u>		<u>✓</u>			<u>33</u>	<u>10</u>	<u>136.8</u>	
<u>2</u>	<u>788A</u>	<u>11.02 X .794 X .795</u>	<u>53.00</u>	<u>39.6</u>	<u>.333</u>		<u>✓</u>			<u>34</u>	<u>4</u>	<u>127.6</u>	

* "RAD." LOAD APPLIED TO RADIAL FACE; "TANG." LOAD APPLIED TO TANGENTIAL FACE.

FIG. 16 Sample Data and Computation Sheet for Toughness Test

13.5 *Weight and Moisture Content*—The specimen shall be weighed immediately before the test, and after the test a moisture section approximately 1 in. (25 mm) in length shall be cut (see 21.1 and 22.1).

14. Shear Parallel to Grain

14.1 This section describes one method of making the shear-parallel-to-grain test that has been extensively used and found satisfactory.

14.2 *Size of Specimens*—The shear-parallel-to-grain tests shall be made on a 2 by 2 by 2-½ in. (50 by 50 by 63 mm) specimens notched in accordance with Fig. 21 to produce failure on a 2 by 2 in. (50 by 50 mm) surface. The actual dimensions of the shearing surface shall be measured (see 22.2).

14.3 *Procedure*—Use a shear tool similar to that illustrated in Figs. 22 and 23, providing a ¼ in. (3 mm) offset between the inner edge of the supporting surface and the plane of the

adjacent edge of the loading surface. Apply the load to and support the specimen on end-grain surfaces. The shear tool shall include an adjustable crossbar to align the specimen and support the back surface at the base plate. Take care in placing the specimen in the shear tool to see that the crossbar is adjusted, so that the edges of the specimen are vertical and the end rests evenly on the support over the contact area. Observe the maximum load only.

14.4 *Speed of Testing*—The load shall be applied continuously throughout the test at a rate of motion of the movable crosshead of 0.024 in. (0.6 mm)/min (see 22.3).

14.5 *Test Failures*—The failure shall be sketched on the datasheet (Note 13). In all cases where the failure at the base of the specimen extends back onto the supporting surface, the test shall be culled.

NOTE 13—See Fig. 24 for a sample data and computation sheet for the tangential-shear-parallel-to-grain test.

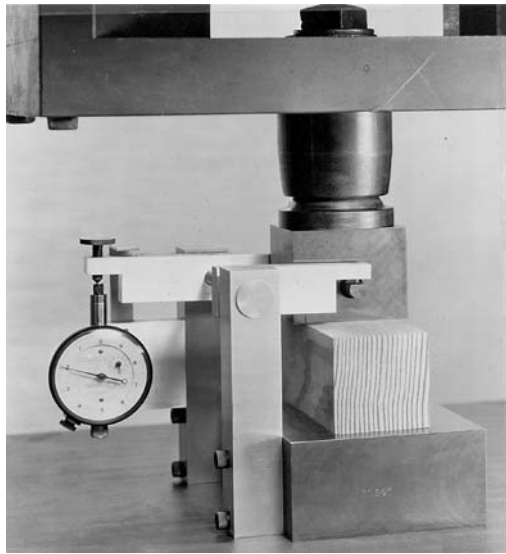

FIG. 17 Compression-Perpendicular-to-Grain Test Assembly Showing Method of Load Application and Measurement of Deformation by Means of Averaging-Type Compressometer

14.6 *Moisture Content*—The portion of the test piece that is sheared off shall be used as a moisture specimen (see 21.1 and 22.1).

15. Cleavage

15.1 *Size of Specimens*—The cleavage tests shall be made on specimens of the form and size in accordance with Fig. 25. The actual width and length at minimum section shall be measured (see 22.2).

15.2 *Procedure*—The specimens shall be held during test in grips as shown in Figs. 26 and 27. Observe the maximum load only.

15.3 *Speed of Testing*—The load shall be applied continuously throughout the test at a rate of motion of the movable crosshead of 0.10 in. (2.5 mm)/min (see 22.3).

15.4 *Sketch of Failure*—The failure shall be sketched on the data sheet (Note 14).

NOTE 14—See Fig. 28 for a sample data and computation sheet for the cleavage test.

15.5 *Moisture Content*—One of the pieces remaining after failure, or a section split along the surface of failure, shall be used as a moisture specimen (see 21.1 and 22.1).

16. Tension Parallel to Grain

16.1 One test method of determining the tension-parallel-to-grain strength of wood is given in the following procedure.

16.2 *Size of Specimens*—The tension-parallel-to-grain tests shall be made on specimens of the size and shape in accordance with Fig. 29. The specimen shall be so oriented that the direction of the annual rings at the critical section on the ends of the specimens, shall be perpendicular to the greater cross-sectional dimension. The actual cross-sectional dimensions at minimum section shall be measured (see 22.2).

16.3 *Procedure:*

16.3.1 Fasten the specimen in special grips (Fig. 30). Deformation shall be measured over a 2 in. (50 mm) central gage length on all specimens. Take load-extension readings until the proportional limit is passed.

16.3.2 Deformations shall be recorded using displacement measurement devices that are capable of a Class A rating when evaluated in accordance with Practice E2309.

16.3.3 Fig. 30 illustrates gripping devices and a type of extensometer that have been found satisfactory.

16.4 *Speed of Testing*—The load shall be applied continuously throughout the test at a rate of motion of the movable crosshead of 0.05 in (1mm)/min (see 22.3).

16.5 *Sketch of Failure*—The failure shall be sketched on the data sheet (Note 15).

NOTE 15—See Fig. 31 for a sample tension-parallel-to-grain data and computation sheet.

16.6 *Moisture Content*—A moisture section about 3 in. (76 mm) in length shall be cut from the reduced section near the failure (see 21.1 and 22.1).

17. Tension Perpendicular to Grain

17.1 *Size of Specimens*—The tension-perpendicular-to-grain tests shall be made on specimens of the size and shape in accordance with Fig. 32. The actual width and length at minimum sections shall be measured (see 22.2).

17.2 *Procedure*—Fasten the specimens during test in grips as shown in Figs. 33 and 34. Observe the maximum load only.

17.3 *Speed of Testing*—The load shall be applied continuously throughout the test at a rate of motion of the movable crosshead of 0.10 in. (2.5 mm)/min (see 22.3).

17.4 *Sketch of Failure*—The failure shall be sketched on the data sheet (Note 16).

NOTE 16—See Fig. 35 for a sample data and computation sheet for the tension-perpendicular-to-grain test.

17.5 *Moisture Content*—One of the pieces remaining after failure or a section split along the surface of failure, shall be used as a moisture specimen (see 21.1 and 22.1).

18. Nail Withdrawal

18.1 *Nails*—Nails used for withdrawal tests shall be 0.0985 in. (2.5 mm) in diameter (Note 17). Bright diamond-point nails shall be used. All nails shall be cleaned before use to remove any coating or surface film that may be present as a result of manufacturing operations. Each nail shall be used once.

NOTE 17—A fivepenny common nail meets this requirement. If difficulty is experienced with high-density woods in pulling the nails without breaking the heads, a sevenpenny cement-coated sinker nail with coating removed by use of a suitable solvent, may be used.

18.2 *Preparation of Specimens*—Nails shall be driven at right angles to the face of the specimen to a total penetration of 1¼ in. (32 mm). Two nails shall be driven on a tangential surface, two on a radial surface, and one on each end. The choice between the two radial and two tangential surfaces shall be such as to give a fair average of the piece. On radial and tangential faces, the nails shall be driven a sufficient distance from the edges and ends of the specimen to avoid splitting. In

FILE NO. 124
 COST CHARGE _____
 LABORATORY NO. 871,620

U. S. DEPARTMENT OF AGRICULTURE
 FOREST SERVICE
 STATION - MADISON DATE - OCT. 25, 1943 SHIP NO. 1590 STICK NO. N-6
 MEASURED _____
 TESTED _____
 WEIGHED _____
 PIECE NO. 4 MARK C

SPECIES RED FIR
 KIND OF TEST COMPRESSION
 LOADING PERPENDICULAR TO GRAIN
 SPAN _____ 6,000
 GAGE LENGTH _____ 5,600
 WIDTH OF PLATE 2 IN. 5,600
 MACHINE 4270
 SPEED OF MACH. 0.012 IN. PER MIN. 5,200
 WEIGHT OF HAMMER _____ 4,800
 HEIGHT 2.015 IN. 4,800
 WIDTH 2.012 IN. 4,400
 LENGTH 6.07 IN. 4,400
 CROSS - SECTION _____ 4,000
 WEIGHT 175.3 GRAMS 4,000
 RINGS PER INCH 25 3,600
 SAP _____ 3,200
 SUMMERWOOD _____ 3,200
 SEASONING KILN DRY 2,800
 MOISTURE 10.8 % 2,800
 TESTED AT 75°F TEMP. 64 % R. H. 2,400
 KIND OF FAILURE _____ 2,400
 REMARKS _____ 2,000
 _____ 1,600
 _____ 1,200
 _____ 800
 _____ 400
 _____ 0

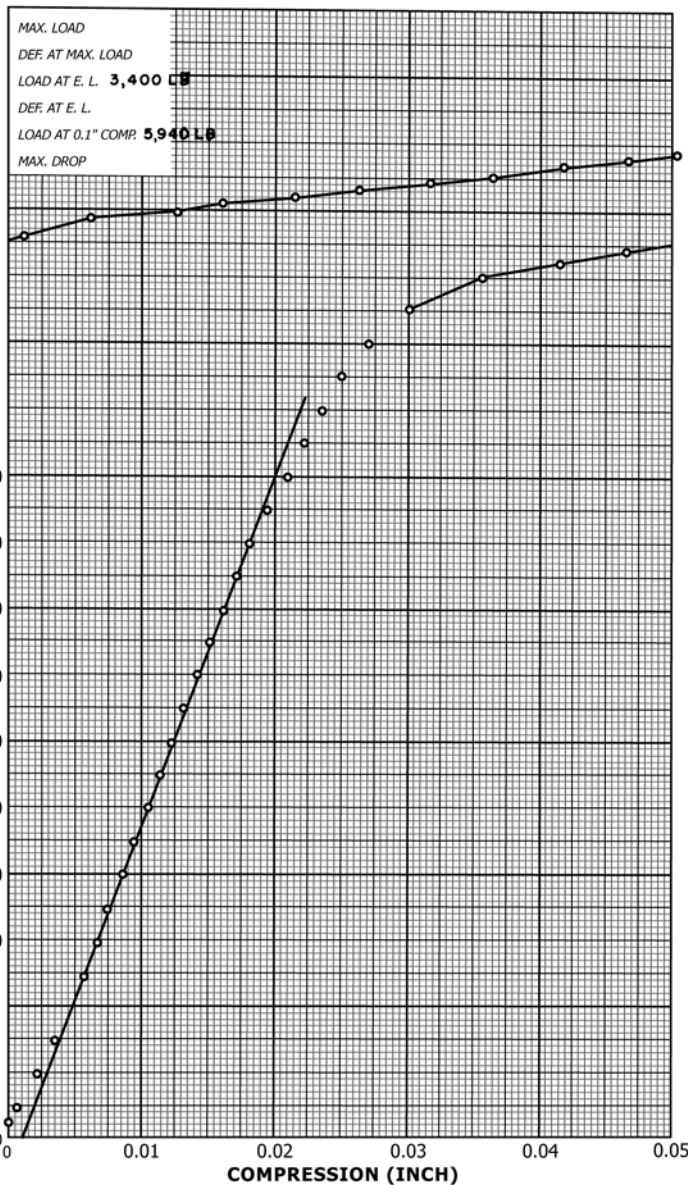

FIG. 18 Sample Data Sheet for Compression-Perpendicular-to-Grain Test

general, nails should not be driven closer than 3/4 in. (19 mm) from the edge or 1 1/2 in. (38 mm) from the end of a piece. The two nails on a radial or tangential face should not be driven in line with each other or less than 2 in. (50 mm) apart.

18.3 Procedure—Withdraw all six nails in a single specimen immediately after driving. Fasten the specimens during the test in grips as shown in Figs. 36 and 37. Observe the maximum load only (Note 18).

NOTE 18—See Fig. 38 for sample nail-withdrawal test data sheet form.

18.4 Speed of Testing—The load shall be applied continuously throughout the test at a rate of motion of the movable crosshead of 0.075 in. (2 mm)/min (see 22.3).

18.5 Weight and Moisture Content—The specimen shall be weighed immediately before driving the nails. After the test, a moisture section approximately 1 in. (25 mm) in length shall be cut from specimen (see 21.1 and 22.1).

19. Specific Gravity and Shrinkage in Volume (Note 19)

NOTE 19—Other test methods for determining specific gravity using specimens of different shape, size, and moisture content are found in Test Methods D2395.

19.1 Size of Specimens—The specific gravity and shrinkage in volume tests shall be made on green 2 by 2 by 6 in. (50 by 50 by 150 mm) specimens. The actual cross-sectional dimensions and length shall be measured (see 22.2).

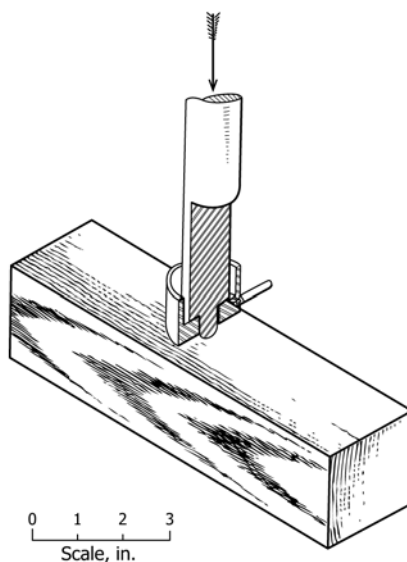

FIG. 19 Diagrammatic Sketch of Test Method of Conducting Hardness Test

19.2 Procedure:

19.2.1 Obtain both specific gravity and shrinkage-in-volume determinations on the same specimen. Make these determinations at approximately 12 % moisture content and at the oven-dry condition (Test Methods D2395).

19.2.2 A carbon impression of the end of the green specimen may be made on the back of the data sheet (Note 20). In like manner, a carbon impression of the same end may be made after the specimen has been conditioned.

NOTE 20—See Fig. 39 for a sample data and computation sheet for the specific gravity and shrinkage-in-volume test.

19.2.3 Weigh the specimen when green (see 22.1) and determine the volume by the immersion test method in accordance with the procedures of Test Methods D2395.

19.2.4 Open-pile the green specimens after immersion and allow them to air-season under room conditions to a uniform moisture content of approximately 12 %. The specimens should then be weighed and the volume determined by the immersion method.

19.2.5 Then, open-pile the specimens used for specific gravity and shrinkage determinations at 12 % moisture content, or duplicate specimens on which green weight and volume measurements have been made prior to conditioning to approximately 12 % moisture content in an oven. Dry at $103 \pm 2^\circ\text{C}$ until approximately constant mass is reached (Test Methods D4442).

19.2.6 After oven-drying, weigh the specimens (see 22.1) and while still warm, immerse them in a hot paraffin bath, taking care to remove them quickly to ensure a thin coating.

19.2.7 Determine the volume of the paraffin-coated specimen by immersion as before.

19.2.8 Fig. 40 illustrates the apparatus used in determining the specific gravity and shrinkage in volume. The use of an automatic balance will facilitate increased rapidity and accuracy of measurements.

20. Radial and Tangential Shrinkage

20.1 Size of Specimens—The radial and tangential shrinkage determinations shall be made on green 1 by 4 by 1-in. (25 by 100 by 25-mm) specimens cut from 1 by 4-in. (25 by 100-mm) boards, edge grain and flat grain, respectively.

20.2 Initial Measurement—The length of all specimens shall be measured.

20.3 Weight—The specimen shall be weighed when green and after subsequent oven-drying (see 21.1).

20.4 Drying:

20.4.1 The green specimens shall be open-piled and allowed to air-season under room conditions to a uniform moisture content of approximately 12 %.

20.4.2 After weighing and measuring, the specimens shall then be open-piled in an oven and dried at $103 \pm 2^\circ\text{C}$ until approximately constant mass is attained (Test Methods D4442).

20.5 Final Measurement—Measurements of mass and length shall be made on the oven-dry specimens (see Note 21).

NOTE 21—See Fig. 41 for a sample data and computation sheet for the radial and tangential-shrinkage test.

20.6 Test Method of Measurement—Fig. 42 illustrates the test method for making the radial and tangential shrinkage measurements. An ordinary micrometer of required accuracy is suitable for this work (see 22.2).

21. Moisture Determination

21.1 Selection—The sample for moisture determinations of each test specimen shall be selected as described for each test.

21.2 Weighing—Immediately after obtaining the moisture sample, all loose splinters shall be removed and the sample shall be weighed (see 22.1).



FIG. 22 Shear-Parallel-to-Grain Test Assembly Showing Method of Load Application Through Adjustable Seat to Provide Uniform Lateral Distribution of Load

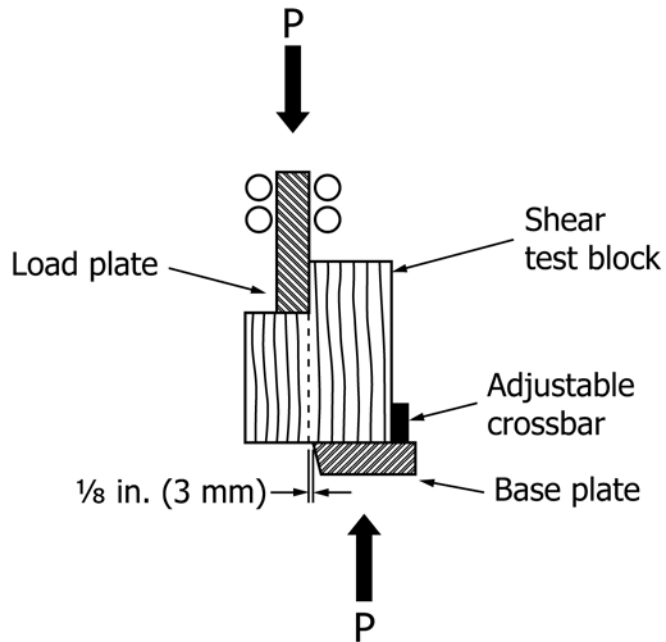

FIG. 23 Shear Parallel to Grain Test Configuration

SHEAR

STATION - Madison
 SPECIES PACIFIC SILVER FIR SHIPMENT NO. 1,651
 PROJECT Str. 1L SEASONING GREEN MEASURED BY _____
 COST CHARGE 01-3-005 MACHINE SPEED 0.0215 WEIGHED BY _____
 LABORATORY NOS. 267,024A-029A MACHINE NO. 4,271 TESTED BY _____
 DATE JAN. 16, 1951 TEMP. 75 °F. REL. HUMIDITY 64 %

STICK NO.	SHEARING SURFACE	SHEARING AREA L" x W"	MAXIMUM LOAD LB.	SHEARING STRENGTH P.S.I.	MOISTURE CONTENT %	REMARKS	SKETCH	
							Diagram 1	Diagram 2
22-N-2-d	R.	2.016 x 2.000	2770	687	40.1			
22-N-6-d	T.	2.020 x 1.998	2775	688	41.1			

FIG. 24 Sample Data and Computation Sheet for Shear-Parallel-to-Grain Test

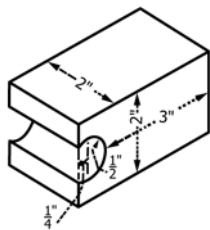

Metric Equivalents				
in.	1/4	1/2	2	3
mm	6	13	50	76

FIG. 25 Cleavage Test Specimen

CLEAVAGE

STATION - Madison

SPECIES PACIFIC SILVER FIR SHIPMENT NO. 1.651

PROJECT Str. 1L SEASONING GREEN MEASURED BY _____

COST CHARGE 01-3-005 MACHINE SPEED 0.1110 WEIGHED BY _____

LABORATORY NOS. 267,036A-041A MACHINE NO. 4269 TESTED BY _____

DATE JAN. 17, 1951 TEMP. 75 °F. REL. HUMIDITY 64%







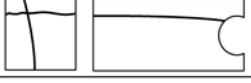
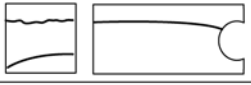

STICK NO.	CLEAVAGE SURFACE	CLEAVAGE AREA L" x W"	MAXIMUM LOAD LB.	LOAD PER INCH OF WIDTH LB.	MOISTURE CONTENT %	REMARKS	SKETCH
<u>22-N-6-d</u>	<u>R.</u>	<u>3.03 x 2.005</u>	<u>315</u>	<u>157</u>	<u>36.9</u>		
<u>22-N-6-d</u>	<u>T.</u>	<u>3.03 x 2.007</u>	<u>330</u>	<u>165</u>	<u>38.5</u>		
							
							
							
							
							
							
							
							
							

FIG. 28 Sample Data and Computation Sheet for Cleavage Test

21.4 *Moisture Content*—The loss in mass, expressed in percent of the oven-dry mass as determined, shall be considered the moisture content of the specimen.

22. Mass and Permissible Variations

22.1 *Mass*—The mass of test specimens and of moisture samples shall be determined to an accuracy of not less than 0.2 %.

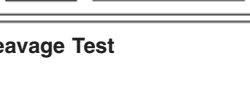
22.2 *Measurements*—Measurements of test specimens shall be made to an accuracy of not less than 0.3 %, except that in no case shall the measurements be made to less than 0.01 in. (0.25 mm). However, measurements of radial and tangential shrinkage specimens shall be made to the nearest 0.001 in. (0.02 mm).

22.3 *Testing Machine Speeds*—The testing machine speed used should not vary by more than 25 % from that specified for a given test. If the specified speed cannot be obtained, the speed used shall be recorded on the data sheet. The crosshead speed shall mean the free-running or no-load speed of crosshead for testing machines of the mechanical drive type and the loaded crosshead speed for testing machines of the hydraulic loading type.

23. Calibration

23.1 All load measurement equipment used in obtaining data shall be calibrated to ensure accuracy in accordance with Practices E4.

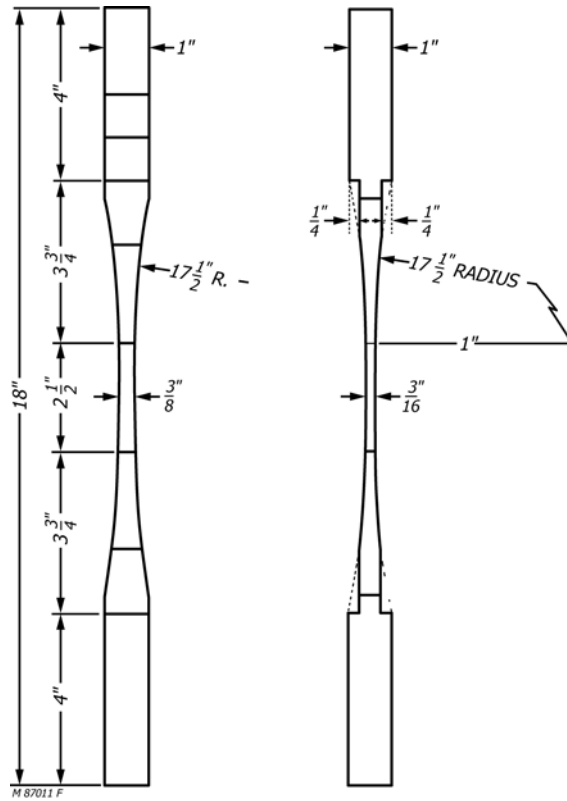

Metric Equivalents

in.	3/16	1/4	3/8	1	2 1/2	3/4	4	17 1/2	18
mm	4.8	6.3	9.5	25	63	95	100	444	460

FIG. 29 Tension-Parallel-to-Grain Test Specimen

24. Precision and Bias

24.1 Statements of precision and bias for the tests have not yet been developed.

25. Keywords

25.1 clear specimens; small clear specimens; timber; wood



FIG. 30 Tension-Parallel-to-Grain Test Assembly Showing Grips and Use of 2 in. (50-mm) Gage Length Extensometer for Measuring Deformation

FILE NO. Str. - 1L
 COST CHARGE 01-3-005
 LABORATORY NO. 266,895 A

U.S. DEPARTMENT OF AGRICULTURE
 FOREST SERVICE
 STATION - MADISON DATE - DEC. 28, 1950

MEASURED _____
 TESTED _____
 WEIGHED _____
 SHIP NO. 1651 STICK NO. N-1
 PIECE NO. 22 MARK C

SPECIES PACIFIC SILVER FIR
 KIND OF TEST TENSION PARALLEL TO GRAIN
 LOADING _____
 SPAN 2 IN.
 GAGE LENGTH _____
 WIDTH OF PLATE _____
 MACHINE 4713
 SPEED OF MACH. 0.036 IN. PER MIN.
 WEIGHT OF HAMMER _____
 HEIGHT _____
 WIDTH _____
 LENGTH _____
 CROSS - SECTION 0.187 X 0.379
 WEIGHT _____ GRAMS
 RINGS PER INCH _____
 SAP _____
 SUMMERWOOD _____
 SEASONING GREEN
 MOISTURE _____
 TESTED AT 75°F. TEMP. 64 % R. H.
 KIND OF FAILURE SPLINTERING
TENSION

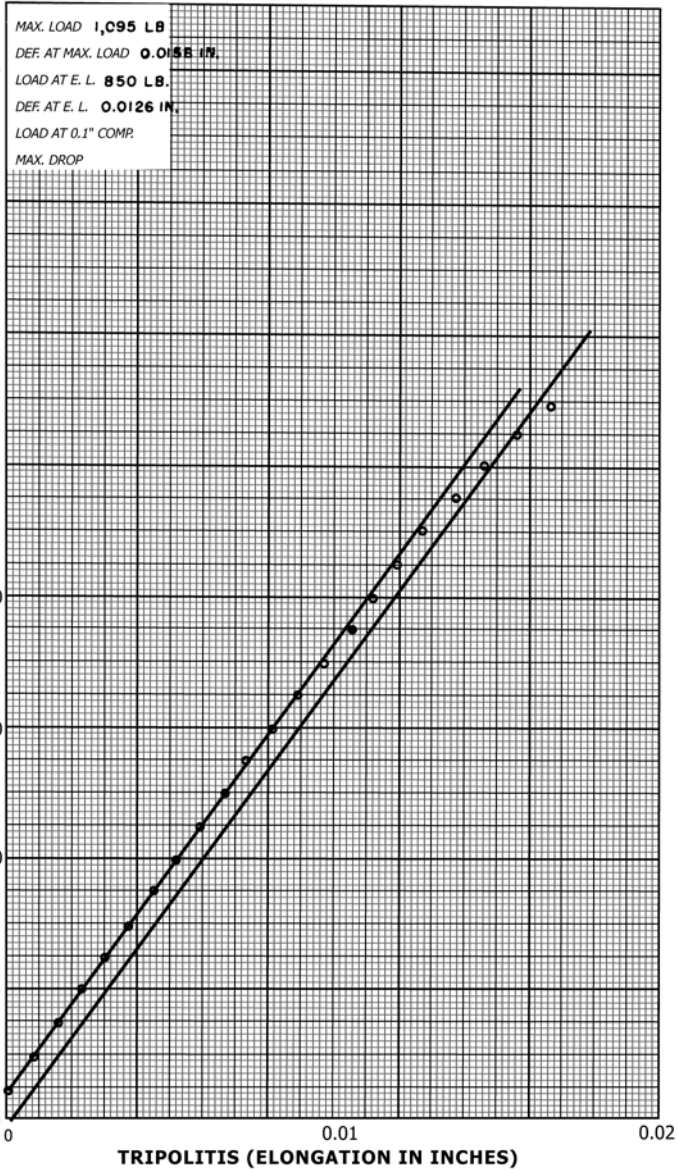

REMARKS _____
 SKETCH

 200

FIG. 31 Sample Data Sheet for Tension-Parallel-to-Grain Test

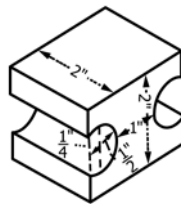

Metric Equivalents				
in	1/4	1/2	1	2
mm	6	13	25	50

FIG. 32 Tension-Perpendicular-to-Grain Test Specimen

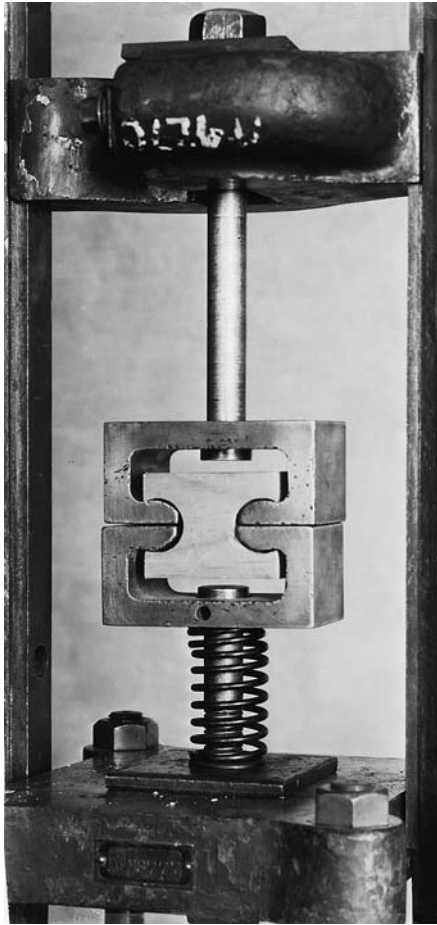
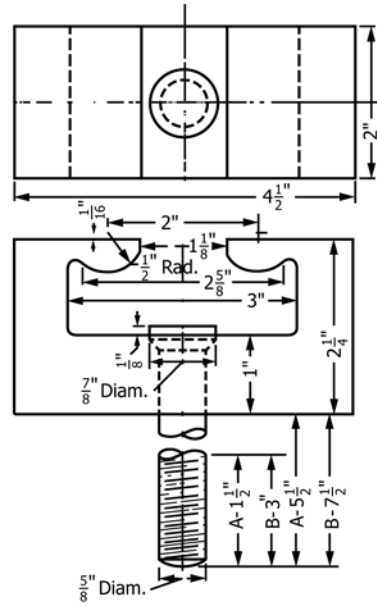

FIG. 33 Tension-Perpendicular-to-Grain Test Assembly



Two pieces included in one set:
 One marked A.
 One marked B.
 Scale-Full Size

Metric Equivalents			
in.	mm	in.	mm
1/16	1.6	2	50
1/8	3.2	2 1/4	57
1/2	13	2 5/8	67
5/8	16	3	76
7/8	22	4 1/2	114
1	25	5 1/2	140
1 1/8	29	7 1/2	190
1 1/2	38		

FIG. 34 Design Details of Grips for Tension-Perpendicular-to-Grain Test

TENSION PERPENDICULAR TO GRAIN

STATION - Madison

SPECIES PACIFIC SILVER FIR SHIPMENT NO. 1,651

PROJECT Str. IL SEASONING GREEN MEASURED BY _____

COST CHARGE 01-3-005 MACHINE SPEED 0.1080 WEIGHED BY _____

LABORATORY NOS. 267048A-053A MACHINE NO. 4,713 TESTED BY _____

DATE JAN. 16, 1951 TEMP. 75 °F. REL. HUMIDITY 64 %











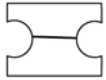





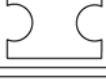

STICK NO.	TENSION SURFACE	TENSION AREA L" x W"	MAXIMUM LOAD LB.	TENSILE STRENGTH P.S.I.	MOISTURE CONTENT %	REMARKS	SKETCH
<u>22-N-6-d</u>	<u>R.</u>	<u>0.98 x 2.011</u>	<u>575</u>	<u>292</u>	<u>33.0</u>		 
<u>22-N-6-d</u>	<u>T.</u>	<u>1.00 x 2.001</u>	<u>635</u>	<u>317</u>	<u>32.4</u>		 
							 
							 
							 
							 
							 
							 
							 
							 

FIG. 35 Sample Data and Computation Sheet for Tension-Perpendicular-to-Grain Test

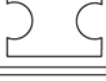
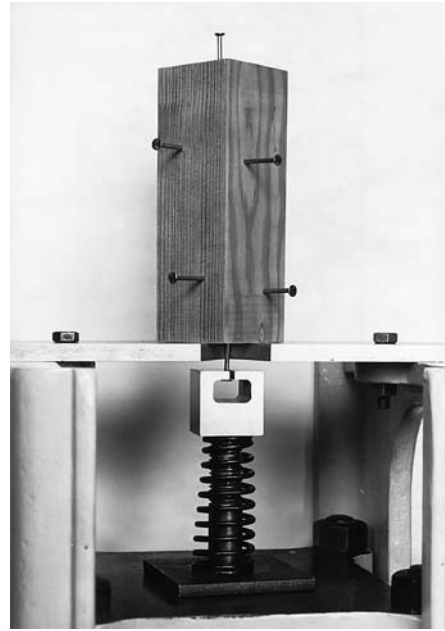
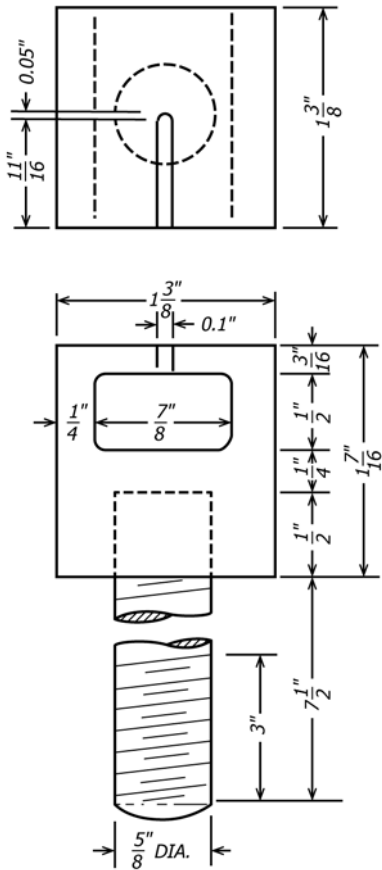

FIG. 37 Nail Withdrawal Test Assembly Showing Specimen in Position for Withdrawal of Nail Driven in One End of the Specimen

Metric Equivalents			
in.	mm	in.	mm
0.05	1.3	1 ¹ / ₁₆	7.5
0.1	2.5	7 ¹ / ₈	22
3 ¹ / ₁₆	4.8	13 ³ / ₈	35
1 ¹ / ₄	6.3	17 ¹ / ₁₆	36
1 ¹ / ₂	13	3	76
5 ¹ / ₈	16	7 ¹ / ₂	190

FIG. 36 Design Details of Grip for Nail Withdrawal Test

NAIL WITHDRAWAL

STATION - Madison SHIPMENT NO. 1,651
 SPECIES PACIFIC SILVER FIR
 PROJECT Str. 1L SEASONING GREEN MEASURED BY _____
 COST CHARGE 01-3-005 MACHINE SPEED 0.071 WEIGHED BY _____
 LABORATORY NOS. 270,270A-278A MACHINE NO. 4269 TESTED BY _____
 DATE FEB. 2, 1951 NAILS, TYPE 7d PLAIN (SINKER) TEMP. 75 °F. REL. HUMIDITY 64 %
DRIVEN 1 1/4"











STICK NO.	DIMENSIONS L" x H" x W"	WEIGHT GM	MOIST. %	SP. GR.	WITHDRAWAL LOADS			REMARKS	SKETCH
					RADIAL SURFACE LB.	TANGENTIAL SURFACE LB.	END SURFACE LB.		
23-N-5-C	6.05 X 1.990 X 1.989	326.4	77.7	.468	180	205	105		
					175	200	110		
					AVERAGE	178	202		
23-N-7-d	6.02 X 1.996 X 1.994	241.3	47.5	.416	180	175	110		
					185	155	75		
					AVERAGE	182	165		
									
					AVERAGE				
									
					AVERAGE				
									
					AVERAGE				
									
					AVERAGE				
									
					AVERAGE				
									
					AVERAGE				
									
					AVERAGE				
									
					AVERAGE				

FIG. 38 Sample Data and Computation Sheet for Nail Withdrawal Test



FIG. 40 Specific Gravity and Shrinkage-in-Volume Test Set-Up

SHRINKAGE - RADIAL AND TANGENTIAL

SPECIES PACIFIC SILVER FIR STATION - Madison SHIPMENT NO. 1,651
 PROJECT Str. 1L MEASURED BY _____
 COST CHARGE 01-3-005 WEIGHED BY _____
 LABORATORY NOS. 266,857A-864A
 DATE _____

STICK NO.	NOMINAL SIZE L" x H" x W"	SHRINKAGE DIRECTION	SEASONING	DATE	RINGS PER INCH	SAP %	SUMMERWOOD %	WIDTH IN.	WEIGHT GM.	MOISTURE %	SHRINKAGE* %
22-2-CD	1 X 1 X 4	R.	GREEN	12/26/50	17	15		3.997	35.50	52.5	
			AIR-DRY								
			OVEN-DRY								4/6/51
REMARKS											
22-2-CD	1 X 1 X 4	T.	GREEN	12/26/50	12	10		3.995	40.00	77.8	
			AIR-DRY								
			OVEN-DRY								4/6/51
REMARKS											
			GREEN								
			AIR-DRY								
			OVEN-DRY								
REMARKS											
			GREEN								
			AIR-DRY								
			OVEN-DRY								
REMARKS											
			GREEN								
			AIR-DRY								
			OVEN-DRY								
REMARKS											
			GREEN								
			AIR-DRY								
			OVEN-DRY								
REMARKS											
			GREEN								
			AIR-DRY								
			OVEN-DRY								
REMARKS											
			GREEN								
			AIR-DRY								
			OVEN-DRY								
REMARKS											

* BASED ON GREEN WIDTH.

FIG. 41 Sample Data and Computation Sheet for Radial- and Tangential-Shrinkage Tests



FIG. 42 Radial- and Tangential-Shrinkage Test Assembly

ASTM International takes no position respecting the validity of any patent rights asserted in connection with any item mentioned in this standard. Users of this standard are expressly advised that determination of the validity of any such patent rights, and the risk of infringement of such rights, are entirely their own responsibility.

This standard is subject to revision at any time by the responsible technical committee and must be reviewed every five years and if not revised, either reapproved or withdrawn. Your comments are invited either for revision of this standard or for additional standards and should be addressed to ASTM International Headquarters. Your comments will receive careful consideration at a meeting of the responsible technical committee, which you may attend. If you feel that your comments have not received a fair hearing you should make your views known to the ASTM Committee on Standards, at the address shown below.

This standard is copyrighted by ASTM International, 100 Barr Harbor Drive, PO Box C700, West Conshohocken, PA 19428-2959, United States. Individual reprints (single or multiple copies) of this standard may be obtained by contacting ASTM at the above address or at 610-832-9585 (phone), 610-832-9555 (fax), or service@astm.org (e-mail); or through the ASTM website (www.astm.org). Permission rights to photocopy the standard may also be secured from the Copyright Clearance Center, 222 Rosewood Drive, Danvers, MA 01923, Tel: (978) 646-2600; http://www.copyright.com/