



# Standard Test Method for Hydrocarbon Types in Liquid Petroleum Products by Fluorescent Indicator Adsorption<sup>1</sup>

This standard is issued under the fixed designation D1319; the number immediately following the designation indicates the year of original adoption or, in the case of revision, the year of last revision. A number in parentheses indicates the year of last reapproval. A superscript epsilon ( $\epsilon$ ) indicates an editorial change since the last revision or reapproval.

*This standard has been approved for use by agencies of the U.S. Department of Defense.*

## 1. Scope\*

1.1 This test method covers the determination of hydrocarbon types over the concentration ranges from 5 to 99 volume % aromatics, 0.3 to 55 volume % olefins, and 1 to 95 volume % saturates in petroleum fractions that distill below 315 °C. This test method may apply to concentrations outside these ranges, but the precision has not been determined. Samples containing dark-colored components that interfere in reading the chromatographic bands cannot be analyzed.

NOTE 1—For the determination of olefins below 0.3 volume %, other test methods are available, such as Test Method [D2710](#).

1.2 This test method is intended for use with full boiling range products. Cooperative data have established that the precision statement does not apply to narrow boiling petroleum fractions near the 315 °C limit. Such samples are not eluted properly, and results are erratic.

1.3 This test method includes a relative bias section based on Practice [D6708](#) accuracy assessment between Test Method D1319 and Test Method [D5769](#) for total aromatics in spark-ignition engine fuels as a possible Test Method D1319 alternative to Test Method [D5769](#) for U.S. EPA spark-ignition engine fuel regulations reporting. The Practice [D6708](#) derived correlation equation is only applicable for fuels in the total aromatic concentration range from 3.3 % to 34.4 % by volume as measured by Test Method D1319 and the distillation temperature  $T_{95}$ , at which 95 % of the sample has evaporated, ranges from 149.1 °C to 196.6 °C (300.3 °F to 385.8 °F) when tested according to Test Method [D86](#).

1.3.1 The applicable Test Method [D5769](#) range for total aromatics is 3.7 % to 29.4 % by volume as reported by Test Method [D5769](#) and the distillation temperature  $T_{95}$  values, at which 95 % of the sample has evaporated, when tested according to Test Method [D86](#) is from 149.1 °C to 196.6 °C (300.3 °F to 385.8 °F).

<sup>1</sup> This test method is under the jurisdiction of ASTM Committee [D02](#) on Petroleum Products, Liquid Fuels, and Lubricants and is the direct responsibility of Subcommittee [D02.04.0C](#) on Liquid Chromatography.

Current edition approved Dec. 1, 2015. Published December 2015. Originally approved in 1954. Last previous edition approved in 2014 as D1319 – 14. DOI: 10.1520/D1319-15.

1.4 The applicability of this test method to products derived from fossil fuels other than petroleum, such as coal, shale, or tar sands, has not been determined, and the precision statement may or may not apply to such products.

1.5 This test method has two precision statements depicted in tables. The first table is applicable to unleaded fuels that do not contain oxygenated blending components. It may or may not apply to automotive gasolines containing lead antiknock mixtures. The second table is applicable to oxygenate blended (for example, MTBE, ethanol) automotive spark ignition fuel samples with a concentration range of 13 to 40 volume percent aromatics, 4 to 33 volume percent olefins, and 45 to 68 volume percent saturates.

1.6 The oxygenated blending components, methanol, ethanol, methyl-*tert*-butylether (MTBE), *tert*-amylmethylether (TAME), and ethyl-*tert*-butylether (ETBE), do not interfere with the determination of hydrocarbon types at concentrations normally found in commercial blends. These oxygenated components are not detected since they elute with the alcohol desorbent. Other oxygenated compounds shall be individually verified. When samples containing oxygenated blending components are analyzed, correct the results to a total-sample basis.

1.7 **WARNING**—Mercury has been designated by many regulatory agencies as a hazardous material that can cause central nervous system, kidney and liver damage. Mercury, or its vapor, may be hazardous to health and corrosive to materials. Caution should be taken when handling mercury and mercury containing products. See the applicable product Material Safety Data Sheet (MSDS) for details and EPA's website—<http://www.epa.gov/mercury/faq.htm>—for additional information. Users should be aware that selling mercury and/or mercury containing products into your state or country may be prohibited by law.

1.8 The values stated in SI units are to be regarded as standard.

1.8.1 *Exception*—Inch-pound units in parentheses are provided for information only.

1.9 *This standard does not purport to address all of the safety concerns, if any, associated with its use. It is the*

\*A Summary of Changes section appears at the end of this standard

responsibility of the user of this standard to establish appropriate safety and health practices and determine the applicability of regulatory limitations prior to use. For specific warning statements, see Section 7, 8.1, and 10.5.

## 2. Referenced Documents

### 2.1 ASTM Standards:<sup>2</sup>

- [D86 Test Method for Distillation of Petroleum Products and Liquid Fuels at Atmospheric Pressure](#)
  - [D1655 Specification for Aviation Turbine Fuels](#)
  - [D2710 Test Method for Bromine Index of Petroleum Hydrocarbons by Electrometric Titration](#)
  - [D3663 Test Method for Surface Area of Catalysts and Catalyst Carriers](#)
  - [D4057 Practice for Manual Sampling of Petroleum and Petroleum Products](#)
  - [D4815 Test Method for Determination of MTBE, ETBE, TAME, DIPE, tertiary-Amyl Alcohol and C<sub>1</sub> to C<sub>4</sub> Alcohols in Gasoline by Gas Chromatography](#)
  - [D5599 Test Method for Determination of Oxygenates in Gasoline by Gas Chromatography and Oxygen Selective Flame Ionization Detection](#)
  - [D5769 Test Method for Determination of Benzene, Toluene, and Total Aromatics in Finished Gasolines by Gas Chromatography/Mass Spectrometry](#)
  - [D6708 Practice for Statistical Assessment and Improvement of Expected Agreement Between Two Test Methods that Purport to Measure the Same Property of a Material](#)
  - [E11 Specification for Woven Wire Test Sieve Cloth and Test Sieves](#)
- ### 2.2 Other Standards:
- [GC/OFID EPA Test Method—Oxygen and Oxygenate Content Analysis<sup>3</sup>](#)
  - [BS 410–1:2000 Test sieves. Technical requirements and testing. Test sieves of metal wire cloth<sup>4</sup>](#)

## 3. Terminology

### 3.1 Definitions of Terms Specific to This Standard:

3.1.1 *aromatics*—the volume percent of monocyclic and polycyclic aromatics, plus aromatic olefins, some dienes, compounds containing sulfur and nitrogen, or higher boiling oxygenated compounds (excluding those listed in 1.6).

3.1.2 *olefins*—the volume percent of alkenes, plus cycloalkenes, and some dienes.

3.1.3 *saturates*—the volume percent of alkanes, plus cycloalkanes.

## 4. Summary of Test Method

4.1 Approximately 0.75 mL of sample is introduced into a special glass adsorption column packed with activated silica

gel. A small layer of the silica gel contains a mixture of fluorescent dyes. When all the sample has been adsorbed on the gel, alcohol is added to desorb the sample down the column. The hydrocarbons are separated in accordance with their adsorption affinities into aromatics, olefins, and saturates. The fluorescent dyes are also separated selectively, with the hydrocarbon types, and make the boundaries of the aromatic, olefin, and saturate zones visible under ultraviolet light. The volume percentage of each hydrocarbon type is calculated from the length of each zone in the column.

## 5. Significance and Use

5.1 The determination of the total volume percent of saturates, olefins, and aromatics in petroleum fractions is important in characterizing the quality of petroleum fractions as gasoline blending components and as feeds to catalytic reforming processes. This information is also important in characterizing petroleum fractions and products from catalytic reforming and from thermal and catalytic cracking as blending components for motor and aviation fuels. This information is also important as a measure of the quality of fuels, such as specified in Specification [D1655](#).

## 6. Apparatus

6.1 *Adsorption Columns*, with precision bore (“true bore” IP designation) tubing, as shown on the right in [Fig. 1](#), made of glass and consisting of a charger section with a capillary neck, a separator section, and an analyzer section; or with standard wall tubing, as shown on the left in [Fig. 1](#). Refer to [Table 1](#) for column tolerance limits.

6.1.1 The inner diameter of the analyzer section for the precision bore tubing shall be 1.60 mm to 1.65 mm. In addition the length of an approximately 100 mm thread of mercury shall not vary by more than 0.3 mm in any part of the analyzer section. In glass-sealing the various sections to each other, long-taper connections shall be made instead of shouldered connections. Support the silica gel with a small piece of glass wool located between the ball and socket of the 12/2 spherical joint and covering the analyzer outlet. The column tip attached to the 12/2 socket shall have a 2 mm internal diameter. Clamp the ball and socket together and ensure that the tip does not tend to slide from a position in a direct line with the analyzer section during the packing and subsequent use of the column. Commercial compression-type connectors may be used to couple the bottom of the separator section (which has been cut square), to the disposable 3 mm analyzer section, provided that the internal geometry is essentially similar to the aforementioned procedure and provides for a smooth physical transition from the inner diameters of the two glass column sections. Similar commercial compression-type connectors may be employed at the terminal end of the 3 mm analyzer section, having an integral porous support to retain the silica gel.

6.1.2 For convenience, adsorption columns with standard wall tubing, as shown on the left in [Fig. 1](#), can be used. When using standard wall tubing for the analyzer section, it is necessary to select tubing of uniform bore and to provide a leakproof connection between the separator and the analyzer sections. Calibrations of standard wall tubing would be impractical; however, any variations of 0.5 mm or greater, as

<sup>2</sup> For referenced ASTM standards, visit the ASTM website, [www.astm.org](http://www.astm.org), or contact ASTM Customer Service at [service@astm.org](mailto:service@astm.org). For *Annual Book of ASTM Standards* volume information, refer to the standard’s Document Summary page on the ASTM website.

<sup>3</sup> Code of Federal Regulations, Part 80 of Title 40, 80.46 (g); also published in the Federal Register, Vol 59, No. 32, Feb. 16, 1994, p. 7828. No longer available.

<sup>4</sup> Available from BSI British Standards, 389 Chiswick High Road, London, W4 4AL, United Kingdom ([www.bsi-global.com](http://www.bsi-global.com)).

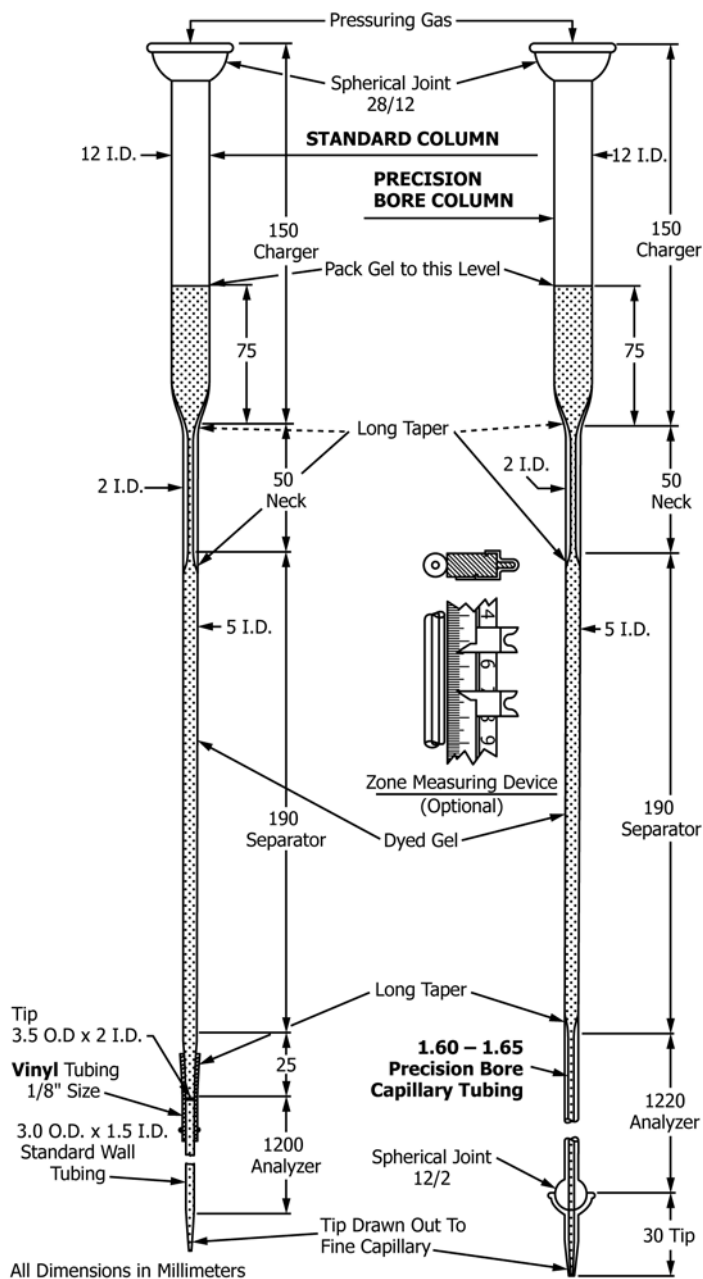

FIG. 1 Adsorption Columns with Standard Wall (left) and Precision Bore (right) Tubing in Analyzer Section

measured by ordinary calipers, in the outside diameter along the tube can be taken as an indication of irregularities in the inner diameter and such tubing should not be used. Prepare the glassware to retain the gel. One way to accomplish this is to draw out one end of the tubing selected for the analyzer section to a fine capillary. Connect the other end of the analyzer section to the separator section with a suitable length of vinyl tubing, making certain that the two glass sections touch. A 30 mm ± 5 mm length of vinyl tubing has been found to be suitable. To ensure a leakproof glass-to-vinyl seal with the analyzer section, it is necessary to heat the upper end of the analyzer section until it is just hot enough to melt the vinyl, then insert the upper end of the analyzer section into the vinyl sleeve. Alternatively,

this seal can be made by securing the vinyl sleeve to the analyzer section by wrapping it tightly with soft wire. Commercial compression-type connectors may be used to couple the bottom of the separator section (which has been cut square), to the 3 mm analyzer section, provided that the internal geometry is essentially similar to the aforementioned procedure and provides for a smooth physical transition from the inner diameters of the two glass column sections. Similar commercial compression-type connectors may be employed at the terminal end of the 3 mm analyzer section having an integral porous support to retain the silica gel.

**TABLE 1 Tolerance Limits to Column Dimensions**

Standard Column Dimensions	
Charger Section	Inside diameter = 12 mm ± 2 mm Pack gel to this level = approximately 75 mm Overall length = 150 mm ± 5 mm
Neck Section	Inside diameter = 2 mm ± 0.5 mm Overall length = 50 mm ± 5 mm
Separator Section	Inside diameter = 5 mm ± 0.5 mm Overall length = 190 mm ± 5 mm
Long taper section below separator	Tip outside diameter = 3.5 mm ± 0.5 mm Tip inside diameter = 2 mm ± 0.5 mm Overall length = 25 mm ± 2 mm
Analyzer Section	Inside diameter = 1. mm5 ± 0.5 mm Standard wall tubing Overall length = 1200 mm ± 30 mm
Precision Bore Column Dimensions	
Charger section	Inside diameter = 12 mm ± 2 mm Pack gel to this level = approximately 75 mm Overall length = 150 mm ± 5 mm
Neck Section	Inside diameter = 2 mm ± 0.5 mm Overall length = 50 mm ± 5 mm
Separator Section	Inside diameter = 5 mm ± 0.5 mm Overall length = 190 mm ± 5 mm
Analyzer Section	Inside diameter = 1.60 mm -1.65 mm Overall length = 1200 mm ± 30 mm
Tip	Overall length = 30 mm ± 5 mm

6.1.3 An alternative pressuring gas connection is shown in Fig. 2. Otherwise, all adsorption column dimensions and requirements are unchanged.

6.2 *Zone-Measuring Device*—The zones may be marked with a glass-writing pencil and the distances measured with a meter rule, with the analyzer section lying horizontally. Alternatively, the meter rule may be fastened adjacent to the column. In this case, it is convenient to have each rule fitted with four movable metal index clips (Fig. 1) for marking zone boundaries and measuring the length of each zone.

6.3 *Ultraviolet Light Source*, with radiation predominantly at 365 nm is required. A convenient arrangement consists of one or two 915 mm or 1220 mm units mounted vertically along the apparatus. Adjust to give the best fluorescence.

6.4 *Electric Vibrator*, for vibrating individual columns or the frame supporting multiple columns.

6.5 *Hypodermic Syringe*, 1 mL, graduated to 0.01 mL or 0.02 mL, with needle 102 mm in length. Needles of No. 18 gauge, 20 gauge, or 22 gauge are satisfactory.

6.6 *Regulator(s)*, capable of adjusting and maintaining the pressure within the 0 kPa to 103 kPa delivery range.

## 7. Reagents and Materials

7.1 *Silica Gel*,<sup>5</sup> manufactured to conform to the specifications shown in Table 2. Determine the pH of the silica gel as follows: Calibrate a pH meter with standard pH 4 and pH 7 buffer solutions. Place 5 g of the gel sample in a 250 mL beaker. Add 100 mL of water and a stirring bar. Stir the slurry on a magnetic stirrer for 20 min and then determine the pH with the calibrated meter. Before use, dry the gel in a shallow vessel at 175 °C for 3 h. Transfer the dried gel to an air tight container while still hot, and protect it thereafter from atmospheric moisture.

NOTE 2—Some batches of silica gel that otherwise meet specifications have been found to produce olefin boundary fading. The exact reason for this phenomenon is unknown but will affect accuracy and precision.

7.2 *Fluorescent Indicator Dyed Gel*—A standard dyed gel,<sup>5,6</sup> consisting of a mixture of recrystallized Petrol Red AB4 and purified portions of the olefin and aromatic dyes obtained by chromatographic adsorption, following a definite, uniform procedure, and deposited on silica gel. The dyed gel shall be stored in a dark place under an atmosphere of nitrogen. When stored under these conditions, the dyed gel can have a shelf life of at least five years. It is recommended that portions of the dyed gel be transferred as required to a smaller working vial from which the dyed gel is routinely taken for analyses.

7.3 *Isoamyl Alcohol*, (3-methyl-1-butanol) 99 %. (**Warning**—Flammable. Health hazard.)

7.4 *Isopropyl Alcohol*, (2-propanol) minimum 99 % purity. (**Warning** —Flammable. Health hazard.)

7.5 *Pressuring Gas*—Air (or nitrogen) delivered to the top of the column at pressures controllable over the range from 0 kPa to 103 kPa gauge. (**Warning**—Compressed gas under high pressure.)

7.6 *Acetone*, reagent grade, residue free. (**Warning**—Flammable. Health hazard.)

7.7 *Buffer Solutions*, pH 4 and 7.

## 8. Sampling

8.1 Obtain a representative sample in accordance with sampling procedures in Practice D4057. For samples that would meet volatility conditions of Group 2 or less of Test Method D86, ensure that the sample is maintained at a temperature of ≤4°C when opening or transferring the sample. (**Warning**—Flammable. Health hazard.)

## 9. Preparation of Apparatus

9.1 Mount the apparatus assembly in a darkened room or area to facilitate observation of zone boundaries. For multiple

<sup>5</sup> If you are aware of alternative suppliers, please provide this information to ASTM International Headquarters. Your comments will receive careful consideration at a meeting of the responsible technical committee,<sup>1</sup> which you may attend.

<sup>6</sup> The sole source of supply of the standard dyed gel known to the committee at this time is produced by UOP LLC, and distributed by Advanced Specialty Gas Equipment Inc, 241 Lackland Drive, Middlesex, New Jersey 08846. Request "FIA Standard Dyed Gel," UOP LLC Product No. 80675.

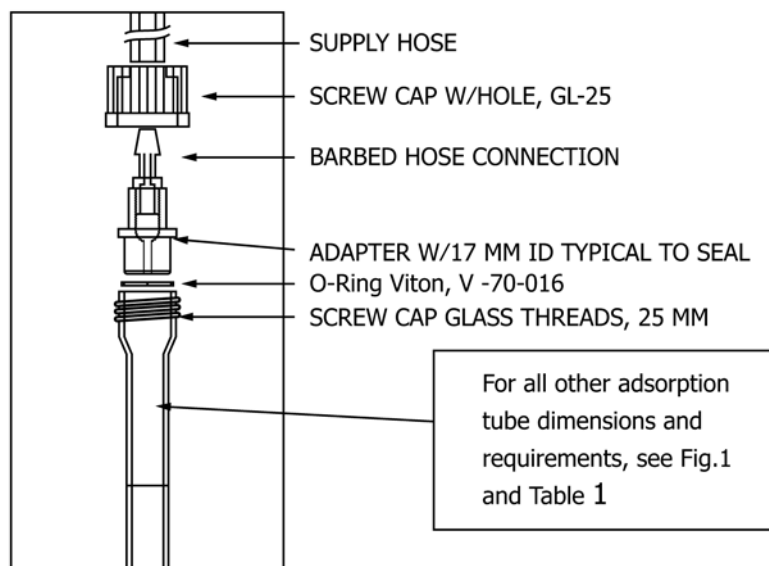

FIG. 2 Adsorption Column with Typical Threaded Joint Pressurizing Gas Connection

TABLE 2 Silica Gel Specifications

Surface area, <sup>A</sup> m <sup>2</sup> /g	430 to 530	
pH of 5 % water slurry	5.5 to 7.0	
Loss on ignition at 955 °C, mass-%	4.5 to 10.0	
Iron content as Fe <sub>2</sub> O <sub>3</sub> , dry basis, mass-ppm	50 max	
Particle Size		
Sieve Number <sup>B</sup>	µm	Mass-%
on 60	250	0.0 max
on 80	180	1.2 max
on 100	150	5.0 max
through 200	75	15.0 max

<sup>A</sup> Silica gel surface area determined by Test Method D3663.

<sup>B</sup> Detailed requirements for these sieves are given in Specification E11 and BS 410-1:2000.

determinations, assemble an apparatus that includes the ultra-violet light source, a rack to hold the columns, and a gas manifold system providing a connection to the desired number of columns.

## 10. Procedure

10.1 Ensure that the silica gel is tightly packed in the column and charger section (up to the appropriate level), which includes the appropriate amount of dyed gel (3 mm to 5 mm) added to an approximately half-full separator section, prior to the start of the sample analysis. See Note 3 for specific guidance.

NOTE 3—One way to prepare the column for analysis is to freely suspend the column from a loose-fitting clamp placed immediately below the pressuring gas connection of the charger section. While vibrating the column along its entire length, add small increments of silica gel through a glass funnel into the charger section until the separator section is half full. Stop the vibrator and add a 3 mm to 5 mm layer of dyed gel. Start the vibrator and vibrate the column while adding additional silica gel. Continue to add silica gel until the tightly packed gel extends approximately 75 mm into the charger section. Wipe the length of the column with a damp cloth while vibrating the column. This aids in packing the column by removing static electricity. Vibrate the column after filling is completed for at least 4 min. More than one column can be prepared simultaneously by mounting several on a frame or rack to which an

electric vibrator is attached.

10.2 Attach the filled column to the apparatus assembly in the darkened room or area, and when a permanently mounted meter rule is used, fasten the lower end of the column to the fixed rule.

10.3 For samples that would meet volatility conditions of Group 2 or less of Test Method D86, chill the sample and a hypodermic syringe to less than 4 °C. Draw 0.75 mL ± 0.03 mL of sample into the syringe and inject the sample approximately 30 mm below the surface of the gel in the charger section.

10.4 Fill the charger section to the spherical joint with isopropyl alcohol. Connect the column to the gas manifold and apply 14 kPa ± 2 kPa gas pressure for 2.5 min ± 0.5 min to move the liquid front down the column. Increase the pressure to 34 kPa ± 2 kPa gauge for another 2.5 min ± 0.5 min and then adjust the pressure required to give a transit time of about 1 h. Usually a gas pressure of 28 kPa to 69 kPa gauge is needed for gasoline-type samples and 69 kPa to 103 kPa gauge for jet fuels. The pressure required will depend on the tightness of packing of the gel and the molecular weight of the sample. A transit time of 1 h is optimum; however, high-molecular weight samples may require longer transit times.

10.5 After the red, alcohol-aromatic boundary has advanced approximately 350 mm into the analyzer section, make a set of readings by quickly marking the boundary of each hydrocarbon zone observed in ultraviolet light in the following sequence. (Warning—Direct exposure to ultraviolet light can be harmful, and operators should avoid this as much as possible, particularly with regard to their eyes.) For the nonfluorescent saturate zone, mark the front of the charge and the point where the yellow fluorescence first reaches its maximum intensity; for the upper end of the second, or olefin zone, mark the point where the first intense blue fluorescence occurs; finally, for the upper end of the third, or aromatic zone, mark the upper end of the first reddish or brown zone. Refer to Fig. 3 as an aid in

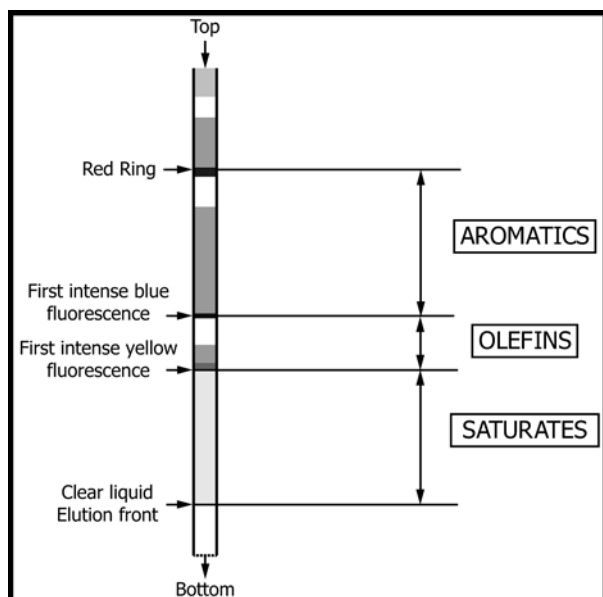

FIG. 3 Pictorial Aid for Identification of Chromatographic Boundaries

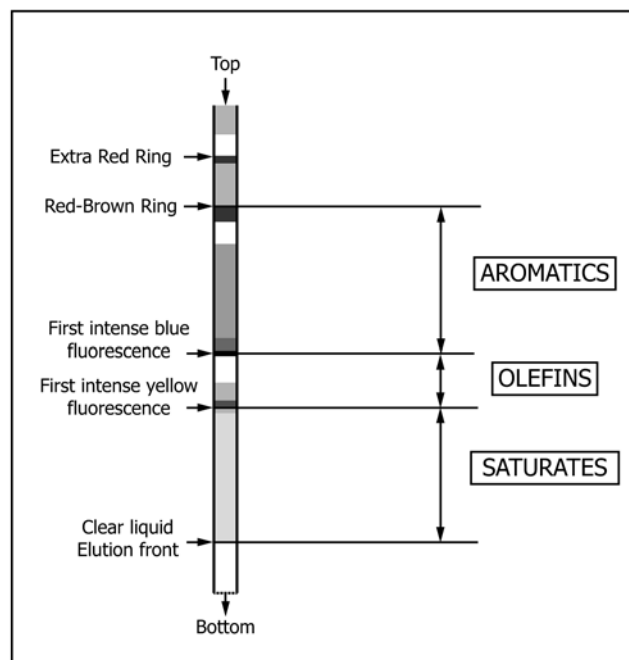

FIG. 4 Pictorial Aid for Identification of Chromatographic Boundaries of Oxygenate Blended Fuel Samples

identifying the boundaries. With colorless distillates, the alcohol-aromatic boundary is clearly defined by a red ring of dye. However, impurities in cracked fuels often obscure this red ring and give a brown coloration, which varies in length, but which shall be counted as a part of the aromatic zone, except that when no blue fluorescence is present, the brown or reddish ring shall be considered as part of the next distinguishable zone below it in the column. With some oxygenate blended fuel samples, another red band may appear several centimetres above the reddish or brown alcohol-aromatic boundary (see Fig. 4) and shall be ignored. Avoid touching the column with the hands while marking the zones. If the boundaries have been marked off with index clips, record the measurements.

NOTE 4—The first maximum intense yellow fluorescence is defined to be the center of the lowest intense yellow fluorescent band.

10.6 When the sample has advanced at least another 50 mm down the column, make a second set of readings by marking the zones in the reverse order as described in 10.5 so as to minimize errors due to the advancement of boundary positions during readings. If the marking has been made with a glass-writing pencil, two colors can be used to mark off each set of measurements and the distances measured at the end of the test with the analyzer section lying horizontally on the bench top. If the boundaries have been marked off with index clips, record the measurements.

10.7 Erroneous results can be caused by improper packing of the gel or incomplete elution of hydrocarbons by the alcohol. With precision bore columns, incomplete elution can be detected from the total length of the several zones, which must be at least 500 mm for a satisfactory analysis. With standard wall tubing, this criterion of total sample length is not strictly applicable because the inside diameter of the analyzer section is not the same in all columns.

NOTE 5—For samples containing substantial amounts of material

boiling above 204 °C, the use of isoamyl alcohol instead of isopropyl alcohol may improve elution.

10.8 Release the gas pressure and disconnect the column. To remove used gel from the precision bore column, invert it above a sink and insert through the wide end a long piece of No. 19 gauge hypodermic tubing with a 45° angle tip. By means of 6 mm outside diameter copper tubing at the opposite end for attaching a rubber tube, connect to a water tap and flush with a rapid stream of water. Rinse with residue-free acetone and dry by evacuation.

## 11. Calculation

11.1 For each set of observations calculate the hydrocarbon types to the nearest 0.1 volume % as follows:

$$\text{Aromatics, \% volume} = (L_a/L) \times 100 \quad (1)$$

$$\text{Olefins, \% volume} = (L_o/L) \times 100 \quad (2)$$

$$\text{Saturates, \% volume} = (L_s/L) \times 100 \quad (3)$$

where:

$L_a$  = length of the aromatic zone, mm,

$L_o$  = length of the olefin zone, mm,

$L_s$  = length of the saturate zone, mm, and

$L$  = sum of  $L_a + L_o + L_s$ .

Average the respective calculated values for each type and report as directed in 12.1. If necessary, adjust the result for the largest component so that the sum of the components is 100 %.

11.2 Eq 1, Eq 2, and Eq 3 calculate concentrations on an oxygenate-free basis and are correct only for samples that are composed exclusively of hydrocarbons. For samples that contain oxygenated blending components (see 1.6), the above results can be corrected to a total sample basis as follows:

$$C' = C \times \frac{100 - B}{100} \quad (4)$$

where:

- $C'$  = concentration of hydrocarbon type (% volume) on a total sample basis,
- $C$  = concentration of hydrocarbon type (% volume) on an oxygenate-free basis, and
- $B$  = concentration of total oxygenate blending components (% volume) in sample as determined by Test Methods **D4815** or **D5599**, or equivalent.

Average the respective calculated values for each type ( $C'$ ) and report as directed in 12.2. If necessary, adjust the result for the largest  $C'$  component so that the sum of the three  $C'$  components plus  $B$  is 100%.

## 12. Report

12.1 For samples that are composed exclusively of hydrocarbons (that is, oxygenate-free samples) report the averaged value for each hydrocarbon type to the nearest 0.1 volume % as calculated in Eq 1-3.

12.2 For samples that contain oxygenated blending components, report the averaged value for each hydrocarbon type corrected to a total sample basis ( $C'$ ) to the nearest 0.1 volume % as determined in Eq 4. Since the total volume % oxygenates in the sample is neither measured nor calculated by Test Method D1319, but rather determined by Test Method **D4815** and **D5599** or equivalent (see variable  $B$  in Eq 4), it is not necessary to report the total volume % oxygenates concentration by Test Method D1319.

## 13. Precision and Bias<sup>7</sup>

13.1 The following criteria are to be used for judging the acceptability of results (95 % probability):

13.1.1 *Repeatability*—The difference between successive test results, obtained by the same operator with the same apparatus under constant operating conditions on identical test material would, in the long run, in the normal and correct operation of the test method, exceed the values in **Table 3** or **Table 4** only in one case in twenty.

13.1.2 *Reproducibility*—The difference between two single and independent results, obtained by different operators working in different laboratories on identical test material would, in the long run, in the normal and correct operation of the test method, exceed the values in **Table 3** or **Table 4** only in one case in twenty.

13.1.3 **Table 3** shall be used for judging repeatability and reproducibility of unleaded fuel samples that do not contain oxygenated blending components. It is applicable over the specified concentration ranges. **Table 4** shall be used for judging the repeatability and reproducibility of oxygenate-containing samples over the specified concentration ranges.

<sup>7</sup> Supporting data regarding the precision obtained from a round robin test for oxygenate containing samples in **Table 3** have been filed at ASTM International Headquarters and may be obtained by requesting Research Report RR:D02-1361.

**TABLE 3** Repeatability and Repeatability–Oxygenate Free Samples

	Volume %			
	Level	Repeatability	Reproducibility	
Aromatics	5	0.7	1.5	
	15	1.2	2.5	
	25	1.4	3.0	
	35	1.5	3.3	
	45	1.6	3.5	
	50	1.6	3.5	
	55	1.6	3.5	
	65	1.5	3.3	
	75	1.4	3.0	
	85	1.2	2.5	
	95	0.7	1.5	
	99	0.3	0.7	
	Olefins	1	0.4	1.7
		3	0.7	2.9
5		0.9	3.7	
10		1.2	5.1	
15		1.5	6.1	
20		1.6	6.8	
25		1.8	7.4	
30		1.9	7.8	
35		2.0	8.2	
40		2.0	8.4	
45		2.0	8.5	
50		2.1	8.6	
55		2.0	8.5	
Saturates		1	0.3	1.1
	5	0.8	2.4	
	15	1.2	4.0	
	25	1.5	4.8	
	35	1.7	5.3	
	45	1.7	5.6	
	50	1.7	5.6	
	55	1.7	5.6	
	65	1.7	5.3	
	75	1.5	4.8	
	85	1.2	4.0	
	95	0.3	2.4	

**TABLE 4** Repeatability and Repeatability for Oxygenate Containing Samples

	Range	Repeatability, Volume %	Reproducibility
Aromatics	13 – 40	1.3	3.7
Olefins <sup>A,B</sup>	4 – 33	0.26X <sup>0.6</sup>	0.82X <sup>0.6</sup>
Saturates	45 – 68	1.5	4.2

<sup>A</sup> X = the volume % of olefins.

<sup>B</sup> Several examples calculated for volume % of olefins from exponential equations listed in **Table 4**:

Level	Repeatability	Reproducibility
4.0	0.6	1.9
10.0	1.0	3.3
20.0	1.6	4.9
30.0	2.0	6.3
33.0	2.1	6.6

13.2 *Bias*—Bias cannot be determined because there are no acceptable reference materials suitable for determining the bias for the procedure in this test method.

NOTE 6—The precision specified in **Table 4** was determined with automotive spark ignition engine fuels that contained oxygenated blending

components as well as non-oxygenated components. Test Methods **D4815** and GC/OFID were both used to determine oxygenates in the interlaboratory study for precision listed in **Table 4**. EPA has replaced its GC/OFID procedure with Test Method **D5599**.

**13.3 Relative Bias**—A relative bias assessment of Test Method D1319 versus Test Method **D5769** for the determination of total aromatics in spark-ignition engine fuel was conducted using data from the ASTM D02 Interlaboratory Crosscheck Program. The assessment was performed in accordance with the requirements of Practice **D6708** with a successful outcome. It was based on measurements of total aromatics in spark-ignition engine fuels supplied to the ASTM Proficiency Test Program by participating laboratories between February 2007 and October 2014 and is documented in Research Report RR:D02-1813.<sup>8</sup>

**NOTE 7**—In the United States, the EPA requires the measurement of total aromatics in spark-ignition engine fuels by Test Method **D5769**. Effective Jan. 1, 2016, there is an allowance in the regulation to use other test methods if they are formally correlated with the specified test method by a consensus organization, for example, ASTM. This relative bias statement is intended to satisfy the requirement and allow use of Test Method D1319 bias-corrected results in the stated concentration ranges in place of Test Method **D5769** for total aromatics content.

**13.3.1** The degree of agreement between results from Test Method D1319 and Test Method **D5769** can be further improved by applying correlation equation (**Eq 5** or **Eq 6**) (Research Report RR:D02-1813),<sup>8</sup> and this correlation equation shall be utilized when reporting compliance with EPA fuels program. Sample-specific bias, as defined in Practice **D6708**, was observed for some samples after applying the bias-correction for the material types and property range listed below.

#### 13.3.2 Correlation Equation:

<sup>8</sup> Supporting data have been filed at ASTM International Headquarters and may be obtained by requesting Research Report RR:D02-1813. Contact ASTM Customer Service at [service@astm.org](mailto:service@astm.org).

Predicted Test Method D5769 =

bias-corrected Test Method D1319 =

$$0.969 \times C_{D1319} - [0.0986 \times (T_{95} - 171.4)] \quad (5)$$

for  $T_{95}$  expressed in degrees Celsius, or

Predicted Test Method D5769 =

bias-corrected Test Method D1319 =

$$0.969 \times C_{D1319} - [0.0548 \times (T_{95} - 340.6)] \quad (6)$$

for  $T_{95}$  expressed in degrees Fahrenheit.

where:

$C_{D1319}$  = volume percent as reported by Test Method D1319, and

$T_{95}$  = distillation temperature at which 95 % of the sample has evaporated when tested in accordance with Test Method **D86**.

**13.3.2.1** The correlation equation is only applicable for fuels in the stated concentration range from 3.3 % to 34.4 % by volume as reported by Test Method D1319 and  $T_{95}$  from 149.1 °C to 196.6 °C (300.3 °F to 385.8 °F) as reported by Test Method **D86**.

**13.3.2.2** The correlation equation is applicable for fuels that when determined by Test Method **D5769** are in the concentration range of 3.7 % to 29.4 % by volume and  $T_{95}$  from 149.1 °C to 196.6 °C (300.3 °F to 385.8 °F) as reported by Test Method **D86**.

**NOTE 8**—The Test Method **D5769** concentration range used to develop the Practice **D6708** assessment may not cover the entire scope indicated in the scope of Test Method **D5769** for total aromatics

**NOTE 9**—The correlation equation was developed from a variety of fuel samples from the ASTM Interlaboratory Crosscheck programs; however, it is recommended that the correlation equation be verified for samples of interest to ensure applicability.

## 14. Keywords

14.1 aromatics; fluorescent indicator adsorption (FIA); hydrocarbon types; olefins; saturates

## SUMMARY OF CHANGES

Subcommittee D02.04.0C has identified the location of selected changes to this standard since the last issue (D1319 – 14) that may impact the use of this standard. (Approved Dec. 1, 2015.)

(1) Added new subsections **1.3** and **13.3**.

Subcommittee D02.04.0C has identified the location of selected changes to this standard since the last issue (D1319 – 13) that may impact the use of this standard. (Approved Oct. 1, 2014.)

(1) Added **Fig. 2** to allow alternative pressuring gas connector.  
 (2) Removed references to spherical joint in subsection **9.1** and subsection **10.1**, **Note 3**.



*ASTM International takes no position respecting the validity of any patent rights asserted in connection with any item mentioned in this standard. Users of this standard are expressly advised that determination of the validity of any such patent rights, and the risk of infringement of such rights, are entirely their own responsibility.*

*This standard is subject to revision at any time by the responsible technical committee and must be reviewed every five years and if not revised, either reapproved or withdrawn. Your comments are invited either for revision of this standard or for additional standards and should be addressed to ASTM International Headquarters. Your comments will receive careful consideration at a meeting of the responsible technical committee, which you may attend. If you feel that your comments have not received a fair hearing you should make your views known to the ASTM Committee on Standards, at the address shown below.*

*This standard is copyrighted by ASTM International, 100 Barr Harbor Drive, PO Box C700, West Conshohocken, PA 19428-2959, United States. Individual reprints (single or multiple copies) of this standard may be obtained by contacting ASTM at the above address or at 610-832-9585 (phone), 610-832-9555 (fax), or [service@astm.org](mailto:service@astm.org) (e-mail); or through the ASTM website ([www.astm.org](http://www.astm.org)). Permission rights to photocopy the standard may also be secured from the Copyright Clearance Center, 222 Rosewood Drive, Danvers, MA 01923, Tel: (978) 646-2600; <http://www.copyright.com/>*