



Standard Test Method for Density and Relative Density (Specific Gravity) of Liquids by Bingham Pycnometer¹

This standard is issued under the fixed designation D1217; the number immediately following the designation indicates the year of original adoption or, in the case of revision, the year of last revision. A number in parentheses indicates the year of last reapproval. A superscript epsilon (ϵ) indicates an editorial change since the last revision or reapproval.

This standard has been approved for use by agencies of the U.S. Department of Defense.

1. Scope*

1.1 This test method covers the measurement of the density of pure hydrocarbons or petroleum distillates boiling between 90 °C and 110 °C that can be handled in a normal fashion as a liquid at the specified test temperatures of 20 °C and 25 °C.

1.2 This test method provides a calculation procedure for the conversion of density to relative density (specific gravity).

1.3 **WARNING**—Mercury has been designated by many regulatory agencies as a hazardous material that can cause central nervous system, kidney and liver damage. Mercury, or its vapor, may be hazardous to health and corrosive to materials. Caution should be taken when handling mercury and mercury containing products. See the applicable product Material Safety Data Sheet (MSDS) for details and EPA's website—<http://www.epa.gov/mercury/faq.htm>—for additional information. Users should be aware that selling mercury and/or mercury containing products in your state or country may be prohibited by law.

1.4 The values stated in SI units are to be regarded as standard. No other units of measurement are included in this standard.

1.5 *This standard does not purport to address all of the safety concerns, if any, associated with its use. It is the responsibility of the user of this standard to establish appropriate safety and health practices and determine the applicability of regulatory limitations prior to use. Specific warning statements are given in Section 7.*

¹ This test method is under the jurisdiction of ASTM Committee D02 on Petroleum Products, Liquid Fuels, and Lubricants and is the direct responsibility of Subcommittee D02.04.0D on Physical and Chemical Methods.

Current edition approved Dec. 1, 2015. Published February 2016. Originally approved in 1952. Last previous edition approved in 2012 as D1217 – 12. DOI: 10.1520/D1217-15.

2. Referenced Documents

2.1 *ASTM Standards*:²

D4052 Test Method for Density, Relative Density, and API Gravity of Liquids by Digital Density Meter

E1 Specification for ASTM Liquid-in-Glass Thermometers

3. Terminology

3.1 *Definitions*:

3.1.1 *density, n*—mass per unit volume at a specified temperature. **D4052**

3.1.2 *relative density, n*—the ratio of the density of a material at a stated temperature to the density of water at a stated temperature. **D4052**

4. Summary of Test Method

4.1 The liquid sample is introduced into a pycnometer, equilibrated to the desired temperature, and weighed. The relative density (specific gravity) or density is then calculated from this weight and the previously determined weight of water that is required to fill the pycnometer at the same temperature, both weights being corrected for the buoyancy of air.

5. Significance and Use

5.1 Density is a fundamental physical property which can be used in conjunction with other properties to characterize pure hydrocarbons and their mixtures.

5.2 This test method was originally developed for the determination of the density of the ASTM Knock Test Reference Fuels *n*-heptane and *isooctane*, with an accuracy of

² For referenced ASTM standards, visit the ASTM website, www.astm.org, or contact ASTM Customer Service at service@astm.org. For *Annual Book of ASTM Standards* volume information, refer to the standard's Document Summary page on the ASTM website.

*A Summary of Changes section appears at the end of this standard

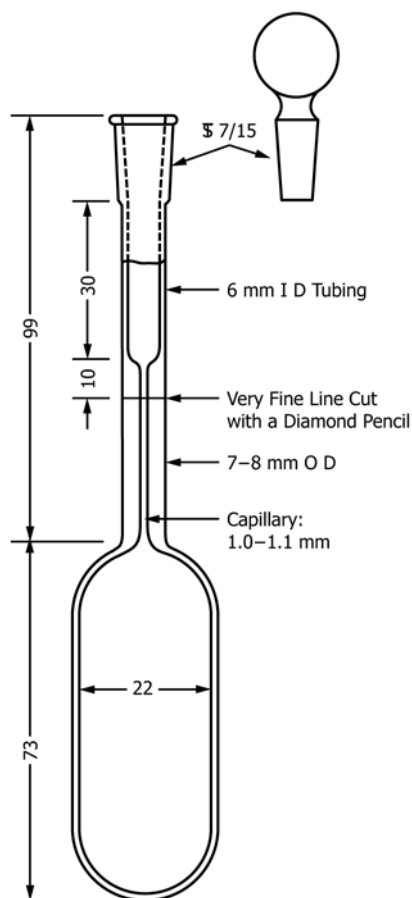

FIG. 1 Bingham-Type Pycnometer, 25 mL

0.00003 g/mL. Although it is no longer employed extensively for this purpose, this test method is useful whenever accurate densities of pure hydrocarbons or petroleum fractions with boiling points between 90 °C and 110 °C are required.

6. Apparatus

6.1 *Pycnometer*, Bingham-type,³ conforming to the dimensions given in Fig. 1, constructed of borosilicate glass, and having a total weight not exceeding 30 g.

6.2 *Constant-Temperature Bath*, provided with suitable pycnometer holders or clips and means for maintaining temperatures constant to ± 0.01 °C in the desired range.

6.3 *Bath Thermometer*, graduated in 0.1 °C subdivisions and standardized for the ice point and the range of use to the nearest 0.01 °C. ASTM Saybolt Viscosity Thermometer 17C as prescribed in Specification E1, designed for tests at 21.1 °C and 25 °C, is recommended. A standardized platinum resistance thermometer may also be used, and offers the best means for observing minute temperature changes in the bath. Whichever means are available, it must be realized that for most hydro-

carbons the density coefficient is about 0.0008 units/°C, and therefore an error of ± 0.013 °C would cause an error of ± 0.00001 in density.

6.4 *Hypodermic Syringe*, 30 mL capacity, of chemically resistant glass, equipped with a 152 mm needle made of stainless steel tubing as shown in Fig. 2.

6.5 *Draw-Off Needle*, made of stainless steel tubing as shown in Fig. 2.

6.6 *Solvent-Cleaning Assembly*, as shown in Fig. 3.

6.7 *Chromic Acid Cleaning Apparatus*, similar to that shown in Fig. 4.

6.8 *Balance*, capable of reproducing weighings within 0.1 mg. Mechanical balances should have sensitivity which causes the pointer to be deflected 2 or 3 scale divisions per 1 mg when carrying a load of 30 g or less on each pan. The balance should be located in a room shielded from drafts and fumes and in which the temperature changes between related weighings (empty and filled pycnometer) do not cause a significant change in the ratio of the balance arms. Otherwise weighings shall be made by the method of substitution, in which the calibrated weights and pycnometer are alternately weighed on the same balance pan. The same balance shall be used for all related weighings.

6.9 *Weights*, whose relative values are known to the nearest 0.05 mg or better. The same set of weights shall be used for the calibration of the pycnometer and the determination of densities.

7. Reagents and Materials

7.1 *Acetone*—(Warning—Extremely flammable. Use adequate ventilation.)

7.2 *Isopentane*—(Warning—Extremely flammable. Avoid buildup of vapors and remove all sources of ignition, especially non-explosion proof electrical apparatus.)

7.3 *Chromic Acid (Potassium Dichromate/Conc. Sulfuric Acid)*—(Warning—Causes severe burns. A recognized carcinogen. Do not get in eyes, or on skin or clothing.)

8. Preparation of Apparatus

8.1 Thoroughly clean the pycnometer with hot chromic acid cleaning solution by means of the assembly shown in Fig. 4. Chromic acid solution (Warning—See 7.3) is the most effective cleaning agent. However, surfactant cleaning fluids have also been used successfully. Mount the apparatus firmly and connect the trap to the vacuum. Warm the necessary amount of cleaning acid in the beaker, place the pycnometer on the ground joint, and evacuate by opening the stopcock to vacuum. Fill the pycnometer with acid by turning the stopcock, repeat several times or remove the filled pycnometer, and allow it to stand for several hours at 50 °C to 60 °C. Remove the acid from the pycnometer by evacuation, empty the acid from the trap, and flush the pycnometer with water. Cleaning should be made in this manner whenever the pycnometer is to be calibrated or whenever liquid fails to drain cleanly from the walls of the pycnometer or its capillary. Ordinarily, the

³ The sole source of supply of the pycnometer known to the committee at this time is Reliance Glass Co., 220 Gateway Rd., Bensenville, IL 60106-0825. If you are aware of alternative suppliers, please provide this information to ASTM International Headquarters. Your comments will receive careful consideration at a meeting of the responsible technical committee,¹ which you may attend.

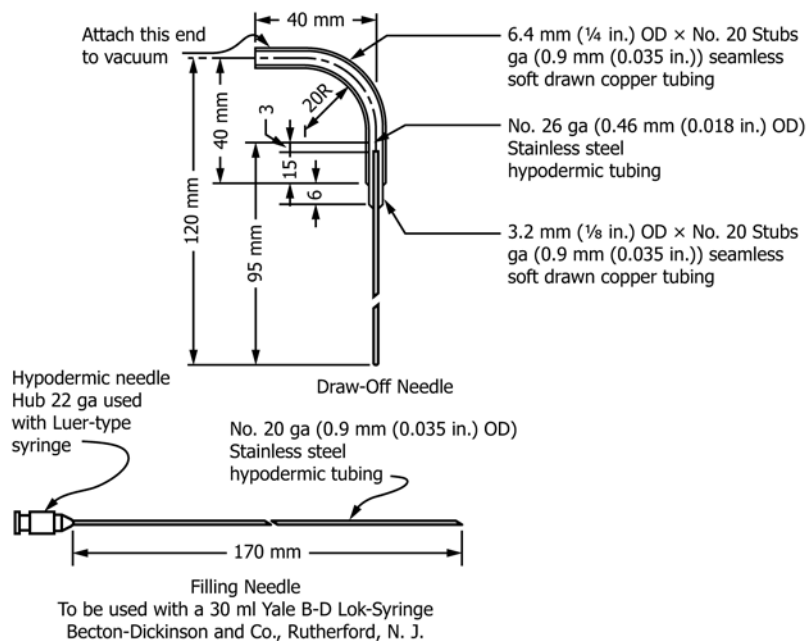

FIG. 2 Accessories for Bingham-Type Pycnometer

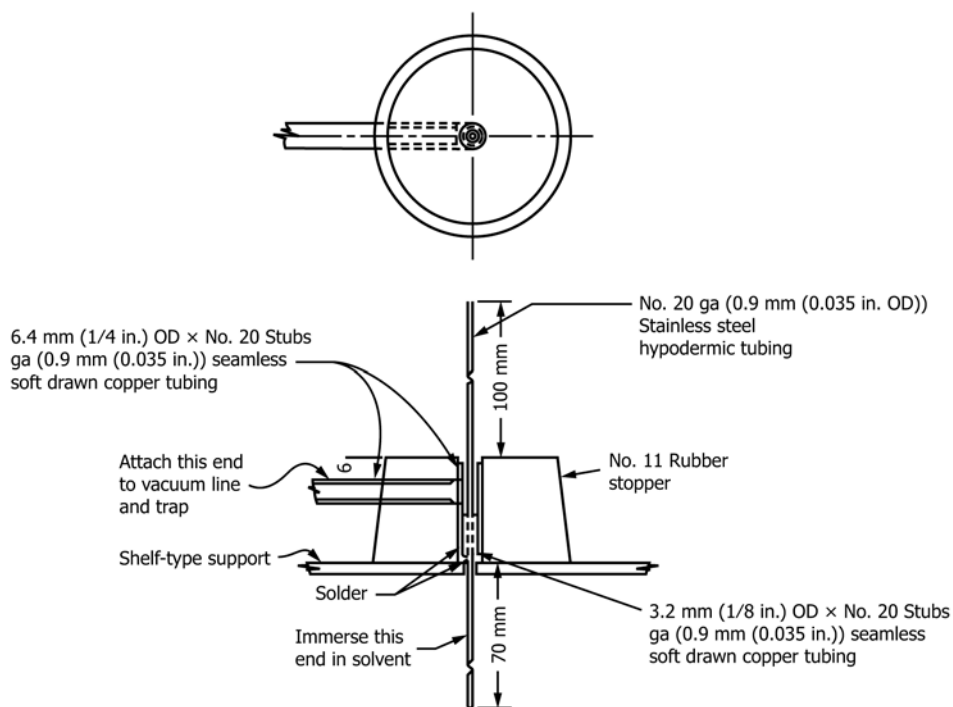

FIG. 3 Cleaner Assembly for Bingham-Type Pycnometer

pycnometer may be cleaned between determinations by washing with a suitable solvent, rinsing with pure, dry acetone, followed by isopentane, and vacuum drying.

8.2 Transfer the pycnometer to the cleaner assembly shown in Fig. 3, with vacuum line and trap attached to the side tube as indicated. Place the pycnometer on the cleaner with the upper hypodermic needle extending upward into the pycnometer, and press the edge of the ground joint on the rubber stopper until the vacuum holds it in place. Draw out all

the liquid or sample. Immerse the lower end of the hypodermic tube in a suitable solvent and draw 20 mL to 25 mL through the pycnometer. Leaving the pycnometer in place, draw air through it until it is dry. Clean the hypodermic syringe with the same apparatus.

9. Calibration of Pycnometer

9.1 Proceeding as directed in Section 10, determine the weight of freshly-boiled and cooled distilled water (distilled

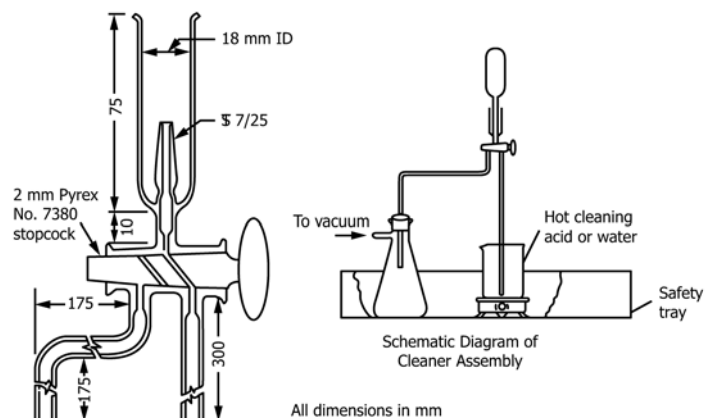

FIG. 4 All-Glass Pycnometer Cleaner Assembly for Use with Hot Chromic Acid Cleaning Solution

from alkaline permanganate through a tin condenser) held by the pycnometer when equilibrated to volume at the bath temperature to be used in the determination. Repeat until at least three values agree to ± 0.2 mg.

10. Procedure

10.1 Using another 25 mL pycnometer as a tare (Note 1), weigh the clean, dry pycnometer to 0.1 mg and record the weight.

NOTE 1—It is convenient to use the lightest of a set of pycnometers as a tare. For best results the treatment and environment of both pycnometer and tare should be identical for some time prior to weighing.

10.2 Cool the sample to 5 °C to 10 °C below the test temperature, and fill the clean 30 mL hypodermic syringe. Transfer the sample to the pycnometer through the filling needle; avoid trapping air bubbles (Warning—Extremely flammable. Avoid buildup of vapors and remove all sources of ignition, especially non-explosion proof electrical apparatus) in the bulb or capillary of the pycnometer. If any are present, draw them into the syringe where possible. Also remove with the syringe or draw-off needle any liquid above the calibration mark in the capillary or overflow reservoir. Dry the remainder with a cotton fiber pipe cleaner or cotton swab which has been dampened slightly with acetone.

NOTE 2—For work of highest accuracy on pure compounds, dissolved air may be removed from the sample by repeated freezing and remelting of the sample under vacuum in the pycnometer.

10.3 Close the pycnometer with the glass stopper and immerse it to a point above the calibration mark in the constant-temperature bath adjusted to a constancy of ± 0.01 °C at the desired temperature. Periodically, or before the liquid expands into the overflow chamber, remove the stopper, raise the pycnometer sufficiently to expose the calibration mark to view, and readjust the liquid level to the mark by withdrawing liquid through the steel draw-off needle until expansion has stopped, indicating that the liquid has reached the temperature of the thermostat. Do not allow the liquid to expand more than 10 mm above the calibration mark at any time, to minimize errors caused by faulty drainage. Allow the contents to equilibrate an additional 10 min and draw the level down exactly to the calibration line, avoiding parallax and using a magnifier, if

necessary, to obtain good visibility. Remove any liquid adhering to the walls above the calibration mark, with the draw-off needle or pipe cleaner, depending upon the volatility of the sample. Portions in the overflow bulb may be removed with a cotton swab moistened with acetone.

10.4 Replace the glass stopper, remove the pycnometer from the bath, wash the outside surface with acetone, and dry thoroughly with a chemically clean, lint-free, slightly damp cloth. Place the pycnometer in or near the balance case for 20 min and weigh to the nearest 0.1 mg. In atmospheres of low humidity (60 % or lower), drying the pycnometer by rubbing with a dry cotton cloth will induce static charges equivalent to a loss of about 1 mg in the weight of the pycnometer. This charge need not be completely dissipated in less than 30 min. The use of about 0.1 mg radium bromide- or polonium-coated foil in the balance case, or maintaining the relative humidity at 60 % or higher, aids in reducing weighing difficulties due to static charges.

10.5 Record temperature of the balance, barometric pressure, and relative humidity.

11. Calculation

11.1 Calculate the true density of the sample as follows:

$$\text{Density, g/mL at } ^\circ\text{C} = \frac{W_s(1 + (d_a/d_s) - (d_a/d_{wt}))d_w/W_w(1 + (d_a/d_w) - (d_a/d_{wt}))}{(d_a/d_{wt})} \quad (1)$$

where:

- W_s = weight in air of sample contained in the pycnometer at the test temperature, g,
- W_w = weight in air of the water contained in the pycnometer at the calibration temperature, g,
- d_w = density of water at the calibration temperature, as obtained from Table 1,
- d_a = density of air in balance case at the time of weighing, as calculated from 10.3,
- d_{wt} = density of weights used in weighing the sample and water (brass = 10.4 g/mL, stainless steel = 7.75 g/mL), and
- d_s = approximate density of sample or

$$(W_s \times d)/W_w \quad (2)$$

TABLE 1 Density of Water^A

NOTE 1—Several metrological entities have issued water density tables and alternative water density data is referenced in publications external to ASTM and this test method. Using water density data from an alternative recognized source does not pose a compliance issue with this test method as the variation in the data typically is limited to the sixth decimal place.

Temperature, °C	Density, g/mL	Temperature, °C	Density, g/mL	Temperature, °C	Density, g/mL
0.01	0.999844	21	0.997996	40	0.992216
3	0.999967	22	0.997773	45	0.990213
4	0.999975	23	0.997541	50	0.988035
5	0.999967	24	0.997299	55	0.985693
10	0.999703	25	0.997048	60	0.983196
15	0.999103	26	0.996786	65	0.980551
15.56	0.999016	27	0.996516	70	0.977765
16	0.998946	28	0.996236	75	0.974843
17	0.998778	29	0.995947	80	0.971790
18	0.998599	30	0.995650	85	0.968611
19	0.998408	35	0.994033	90	0.965310
20	0.998207	37.78	0.993046	99.9	0.958421

^A Densities conforming to the International Temperature Scale 1990 (ITS 90) were extracted from Lemmon, E. W., McLinden, M. O., and Friend, D. G., "Thermophysical Properties of Fluid Systems," *NIST Chemistry WebBook*, NIST Standard Reference Database No. 68, Eds. P.J. Linstrom and W.G. Mallard, National Institute of Standards and Technology, Gaithersburg, MD, <http://webbook.nist.gov> (retrieved July 24, 2013).

11.2 The equation assumes that the weighings of the pycnometer empty and filled are made in such a short time interval that the air density has not changed. If significant change should occur, the calculated apparent weight of the sample, W_s , in this equation, must be corrected for the difference in air buoyancy exerted on the pycnometer as follows:

$$W_s = W_{PS}^2 - W'_P(1 + (d'_a/2.2) - (d'_a/d_{wt})) / (1 + (d_a^2/2.2) - (d_a^2/d_{wt})) \quad (3)$$

where:

W_{PS}^2 = weight of pycnometer and contained sample under second or final air density,

W'_P = weight of pycnometer in air of first density,

d'_a = density of air when weighing empty pycnometer,

d_a^2 = density of air when weighing filled pycnometer,

d_{wt} = density of weights, and

2.2 = borosilicate glass.

Likewise, if the pycnometer, empty and filled with water for calibration, is weighed under different air densities a similar correction for different air buoyancies shall be applied.

11.3 Calculate the relative density (specific gravity) of the sample by dividing the density as obtained in 11.1 by the relative density of water at the reference temperature obtained from Table 1.

11.4 Calculate the density of air in the balance room as follows:

Air density (d_a), g/mL (4)

$$= [(B - 0.3783 Hp)(0.000465)] / (273 + t)$$

where:

B = barometric pressure, mm Hg, corrected to 0 °C,

H = relative humidity, decimal fraction,

p = vapor pressure of water at temperature t , mm Hg, and

t = room temperature, °C.

NOTE 3—If this test method is to be used frequently, a considerable amount of calculation can be avoided by use of a gas density balance to determine the air density. Weigh a sealed 250 mL glass bulb at several different air densities and plot the weight against the air density. To determine the air density at some later time, weigh the bulb and read the air density from the point on the curve corresponding to the weight.

11.5 To calculate the density or relative density (specific gravity) at any test temperature, t , other than the calibration temperature, t_c (to correct for the cubical coefficient of thermal expansion of borosilicate glass), divide the value obtained in 10.1 or 10.2 by the following expression:

$$1 + 9.6 \times 10^{-6} (t - t_c) \quad (5)$$

12. Report

12.1 In reporting density, give the test temperature and the units (for example, density, 20 °C = x.xxxxx g/mL). In reporting relative density (specific gravity), give both the test temperature and the reference temperature, but no units (for example, relative density (specific gravity), 20/4 °C = x.xxxxx). Carry all calculations to one digit beyond the last significant figure, but report the final result to the fifth decimal place (0.00001).

13. Precision and Bias

13.1 *Precision*—Results, using the 25 mL Bingham-type pycnometer, should not differ from the mean by more than the following amounts:

Repeatability	Reproducibility
One Operator and Apparatus 0.00002	Different Operators and Apparatus 0.00003

NOTE 4—The precision for this test method was not obtained in accordance with Research Report RR:D02-1007.⁴

13.2 *Bias*—The difference of results from the established values when compared to pure reference materials is not expected to be more than ±0.00003 g/mL. Specific bias has not been established by cooperative testing.

14. Keywords

14.1 density; pycnometer; relative density; specific gravity

⁴ Filed at ASTM International Headquarters and may be obtained by requesting Research Report RR:D02-1007.

SUMMARY OF CHANGES

Subcommittee D02.04 has identified the location of selected changes to this standard since the last issue (D1217 – 12) that may impact the use of this standard. (Approved Dec. 1, 2015.)

(1) Revised water density references values in **Table 1**.

ASTM International takes no position respecting the validity of any patent rights asserted in connection with any item mentioned in this standard. Users of this standard are expressly advised that determination of the validity of any such patent rights, and the risk of infringement of such rights, are entirely their own responsibility.

This standard is subject to revision at any time by the responsible technical committee and must be reviewed every five years and if not revised, either reapproved or withdrawn. Your comments are invited either for revision of this standard or for additional standards and should be addressed to ASTM International Headquarters. Your comments will receive careful consideration at a meeting of the responsible technical committee, which you may attend. If you feel that your comments have not received a fair hearing you should make your views known to the ASTM Committee on Standards, at the address shown below.

This standard is copyrighted by ASTM International, 100 Barr Harbor Drive, PO Box C700, West Conshohocken, PA 19428-2959, United States. Individual reprints (single or multiple copies) of this standard may be obtained by contacting ASTM at the above address or at 610-832-9585 (phone), 610-832-9555 (fax), or service@astm.org (e-mail); or through the ASTM website (www.astm.org). Permission rights to photocopy the standard may also be secured from the Copyright Clearance Center, 222 Rosewood Drive, Danvers, MA 01923, Tel: (978) 646-2600; <http://www.copyright.com/>