



Designation: D1185 – 98a (Reapproved 2017)

Standard Test Methods for Pallets and Related Structures Employed in Materials Handling and Shipping¹

This standard is issued under the fixed designation D1185; the number immediately following the designation indicates the year of original adoption or, in the case of revision, the year of last revision. A number in parentheses indicates the year of last reapproval. A superscript epsilon (ϵ) indicates an editorial change since the last revision or reapproval.

This standard has been approved for use by agencies of the U.S. Department of Defense.

1. Scope

1.1 These test methods cover the performance of pallets and related structures, functioning as skids, bases, platforms, and bins in materials handling and shipping. Their use facilitates the protection of both packaged and unpackaged products during storage and transportation. The test methods include measurements of the relative resistance of pallets and related structures to deformations, damages, and structural failures which detrimentally affect the functionality of the unit load.

1.2 These test methods include conditioning requirements, static stiffness and strength tests, and dynamic tests of structural reliability. These test methods are used to evaluate the relative performance of new, used, or reconditioned general and special-purpose pallets fabricated from various materials including solid wood, wood composites, fiberboard, honeycomb, plastics, or metal, or to compare the performance of such pallets and related structures to specified performance criteria. Recommended criteria for all tests specified in this standard are listed in [Appendix X2](#).

1.2.1 These test methods are also used to classify pallets as single- or multiple-use pallets and to determine the safe working loads for pallets under specified load and support conditions.

1.3 *Nonmandatory Preliminary Tests*—Because each pallet may be used under several different conditions of load and support, pallet-design considerations and safe working-load estimates shall be based on that condition under which the pallet offers least resistance or is most severely stressed.

1.3.1 Preliminary, short-duration static tests up to the ultimate (see [8.2](#), [8.3](#), and [8.4](#)) shall be performed on previously non-tested pallets to determine which load and support conditions influence most severely the pallet load-carrying capacity and safe working loads.

1.3.2 During the development of prototypes leading to designs that will be subject to acceptance testing, as described in [1.4](#), these preliminary tests shall include the free-fall drop tests in accordance with [9.1](#).

1.4 *Mandatory Acceptance Tests* :

1.4.1 *General-Purpose Pallets*—When the objective of the test is to determine the safe working load or to classify a general-purpose pallet as a single- or multiple-use pallet, all tests described in these test methods shall be performed in the order specified. The same pallet shall be used for all static and dynamic tests, where feasible.

1.4.2 *Special-Purpose Pallets*—When the objective of the test is to determine the safe working load or to classify a special-purpose pallet, as a single- or multiple-use pallet, only those tests representing the intended condition of use shall be performed. Certain special-purpose pallet designs, because of the pallet size, its shape, or the material of fabrication, or combinations thereof, cannot be reliably tested using this methodology. When available, alternative test methods should be used.

1.4.3 *Field Testing*—It is recommended that pallet designs passing these acceptance tests be further subjected to field testing in the distribution environment.

1.5 *Simulation of the Distribution Environment*—These test methods are not intended to lead to exact simulations of pallet performance in the distribution environment. These test methods are designed to relate to practice with the added provision that they are repeatable, do not depend on exceptional skills, and are safe to conduct without elaborate precautions. The test findings are not expected to lead to unalterable conclusions. Testing in the distribution environment may be necessary to verify the results obtained from laboratory tests.

1.6 *This standard does not purport to address all of the safety concerns, if any, associated with its use. It is the responsibility of the user of this standard to establish appropriate safety and health practices and determine the applicability of regulatory limitations prior to use. Specific warnings are given in [9.5.3.5](#).*

¹ These test methods are under the jurisdiction of ASTM Committee D10 on Packaging and are the direct responsibility of Subcommittee D10.21 on Shipping Containers and Systems - Application of Performance Test Methods.

Current edition approved May 1, 2017. Published July 2017. Originally approved in 1951. Last previous edition approved in 2009 as D1185 – 98a(2009). DOI: 10.1520/D1185-98AR17.

1.7 This international standard was developed in accordance with internationally recognized principles on standardization established in the Decision on Principles for the Development of International Standards, Guides and Recommendations issued by the World Trade Organization Technical Barriers to Trade (TBT) Committee.

2. Referenced Documents

2.1 ASTM Standards:²

- D642 Test Method for Determining Compressive Resistance of Shipping Containers, Components, and Unit Loads
 - D996 Terminology of Packaging and Distribution Environments
 - D999 Test Methods for Vibration Testing of Shipping Containers
 - D1505 Test Method for Density of Plastics by the Density-Gradient Technique
 - D1761 Test Methods for Mechanical Fasteners in Wood
 - D2395 Test Methods for Density and Specific Gravity (Relative Density) of Wood and Wood-Based Materials
 - D4003 Test Methods for Programmable Horizontal Impact Test for Shipping Containers and Systems
 - D4332 Practice for Conditioning Containers, Packages, or Packaging Components for Testing
 - D4442 Test Methods for Direct Moisture Content Measurement of Wood and Wood-Based Materials
 - D4444 Test Method for Laboratory Standardization and Calibration of Hand-Held Moisture Meters
 - D4728 Test Method for Random Vibration Testing of Shipping Containers
 - F680 Test Methods for Nails
 - F1575 Test Method for Determining Bending Yield Moment of Nails
 - F1667 Specification for Driven Fasteners: Nails, Spikes, and Staples
- ### 2.2 ASME Standard:³
- MH 1 Pallets, Slipsheets, and Other Bases for Unit Loads
- ### 2.3 ISO Standard:³
- ISO 445 Pallets for Material Handling— Vocabulary
- ### 2.4 TAPPI Standard:⁴
- TAPPI T 208 OM - 89 Moisture in Wood, Pulp, Paper and Paper Board by Tolvene Distillation

3. Terminology

3.1 Definitions:

3.1.1 The following standards are applicable, with Terminology D996, to be considered the governing standard in the case of a dispute: Terminology D996, MH 1, and ISO 445.

3.1.2 *datum load*—a preload level applied to the specimen to reduce test variables as influenced by the test setup during

the initial stage of testing. Test deformations shall be assumed to be zero at this preload level.

3.1.3 *general-purpose pallets*—pallets designed and constructed to support a wide range of loads using a variety of applicable handling devices.

3.1.4 *preliminary safe working load*—an estimate of the safe working load of a pallet not yet confirmed by all of the appropriate tests specified in these test methods.

3.1.5 *safe working load*—The maximum load, determined from tests, that a pallet can support without failure in handling, storage, and distribution including an appropriate allowance for variations in performance as well as necessary safety factors.

3.1.6 *special-purpose pallets*—pallets designed and constructed to support a specified load using certain handling devices.

4. Significance and Use

4.1 Static compression and bending tests provide data that are used to estimate stiffness, strength, and safe working loads for pallets under specified load and support conditions. These estimates provide a basis for designing pallets and comparing the performance between pallets of different designs and constructions.

4.2 Dynamic tests provide data which are used to estimate the physical durability and functionality of a pallet in specified material handling and shipping environments. These estimates provide a basis for designing single or multiple-use pallets.

4.3 Other tests may be performed to assess the properties of specific materials (Test Methods D2395, D4442, D4444, and T 208 OM) and connecting devices (Test Methods D1761, F680, Test Method F1575, and Specification F1667), design features, use applications, and other variables encountered.

5. Materials

5.1 These test methods are pertinent to pallets constructed of materials listed in Table 1.

6. Sampling

6.1 Sampling shall provide for the selection of representative specimens. The number of test replications required varies. At least three replications per pallet design shall be tested.

7. Conditioning

7.1 Some pallets are constructed of materials whose properties are affected by changes in temperature, relative humidity, and environmental moisture conditions prior to and during use in the distribution environment. Prior to test, these pallets shall be conditioned as described in Table 1.

7.2 Where conditioning influences pallet performance, the specified test-specimen environment shall exist during the time of testing. If the test environment cannot be maintained at the required conditioning level, the tests shall be performed immediately after the pallet has been removed from the conditioning environment. Immediately after each individual test, specimens subjected to Environments A or B shall be

² For referenced ASTM standards, visit the ASTM website, www.astm.org, or contact ASTM Customer Service at service@astm.org. For Annual Book of ASTM Standards volume information, refer to the standard's Document Summary page on the ASTM website.

³ Available from American National Standards Institute (ANSI), 25 W. 43rd St., 4th Floor, New York, NY 10036, http://www.ansi.org.

⁴ Available from Technical Association of the Pulp and Paper Industry (TAPPI), 15 Technology Parkway South, Norcross, GA 30092, http://www.tappi.org.

TABLE 1 Conditioning and Testing Environments

Conditioning Environment	Temperature, °C	Relative Humidity, %	Minimum Conditioning Time, h	Pallet Material
	no conditioning required			unprocessed sawn wood assembled with metal connectors ^{A,B} metals
A	+60 ± 2 ^C	...	24	plastics ^B
B	-25 ± 3	
C	25 ± 3	90 ± 5	48	paper-based materials, wood assembled with adhesives, and processed wood (that is, plywood, strandboard, particle board, and other wood based materials). ^D
D	20 ± 5	...	24	

^A The moisture content of unprocessed sawn wood components shall represent the maximum that would occur during the use of the pallet.

^B Special purpose pallets may be conditioned to temperatures reflecting anticipated use conditions.

^C 45°C shall be the temperature used for 8.4, Pallet Bending Tests.

^D Environment D shall be used for pallets made of these materials when it is expected that the pallets may be exposed to water in the distribution environment.

returned to the conditioning environment for a minimum of 1 h prior to the next test. For additional details concerning conditioning procedures, see Practice D4332.

7.3 For wood or wood-base materials, the moisture content of selected components shall be observed and recorded at the beginning of the test (see Test Methods D4442 and D4444).

7.4 Pallets fabricated of several different materials, such as composites, shall be conditioned to the extremes applicable to the materials in the structure.

STATIC TESTS

8. Summary of Test Method

8.1 Static tests are performed to determine the strength and stiffness of the pallet under specified load and support conditions. For all static tests described in 8.3 – 8.5, the test load applied shall include the mass of all load applicators supported by the pallet. The performance criteria in X2.1 of Appendix X2 may be used to determine the safe working load of a pallet (see 1.2.1 and 1.4).

8.2 Apparatus:

8.2.1 *Calibrated Compression Testing Machine*, with sufficient load capacity to structurally fail the pallet and a sufficiently large bed to support the pallet and the pallet supports (see 8.3.2).

8.2.2 *Floating Head*, used for application of rigid loads.

8.2.3 *Fixed Head*, used for supporting load at prescribed angles (see 8.4.1).

8.2.4 “*Dead Weights*” simulate the desired load, used instead of a testing machine. These dead weights shall conform to the description in 8.4.1.

8.2.5 Deformations shall be monitored and recorded using micrometer dial gages or other suitable measuring devices, such as calibrated sensors, capable of measuring deformation or deflection of 0.025 mm (0.001 in.).

8.2.6 *Calibration and Standardization of the Compression Test Apparatus*—The accuracy of the compression testing device shall be verified using procedures described in Test Method D642.

8.3 *Compression Tests on Pallet Deck Spacers or Supports*—The purpose of this test is to determine the resistance to compression of deck spacers (stringers, blocks, and posts) of pallets.

8.3.1 *Deformation Measurements*—When tested in accordance with the procedure specified in 8.3.2, record the change in the height, *y*, at Locations A, B, C, and D, as shown in Fig. 1, relative to the ground (or test frame), (1) at the datum load (see 8.3.2 and 3.1); (2) at the beginning and end of the full-load period; and (3) upon unloading, at the datum load (see 8.3.2), every 5 min until successive readings are practically identical (limited to a maximum period of 1 h).

8.3.1.1 When, due to test procedure, the deflections at Locations A, B, C, and D are not identical, the average of the four observations shall be used as the test measure (see Fig. 1).

8.3.2 *Test Procedure:*

8.3.2.1 Place the pallet in a normal position on a flat, hard, rigid, and horizontal surface. Place a rigid load applicator of sufficient size to overlap the pallet edges and ends, as shown in Fig. 1.

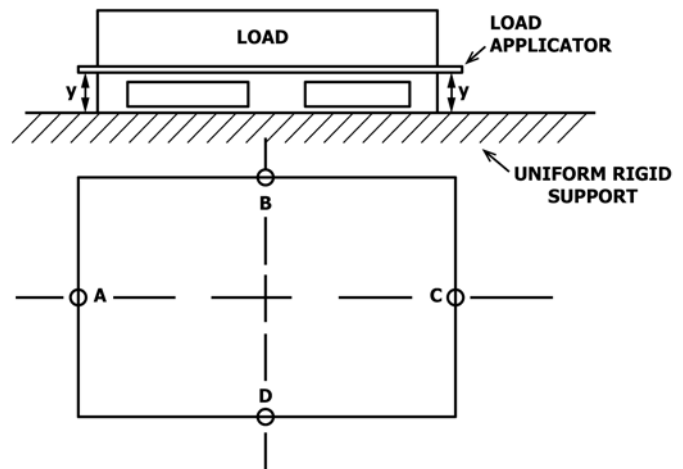

FIG. 1 Load and Support Conditions and Locations of Deflection Measurements for Compression Tests of Pallet Deck Spacers or Supports

8.3.2.2 Gradually apply the test load at a uniform rate of 0.5 ± 0.1 in./min from 0 to $0.10 R$, where R is the preliminary safe working load based on the preliminary test or on that determined from tests to failure. This value of $0.10 R$ shall be the datum load for subsequent deflection measurements (see Note 1). Apply the full test load of $1.1 \cdot M \cdot R$, where M is the maximum number of pallet loads expected in a stack during use. The datum as well as the full test loads shall be applied in not less than 1 min or more than 5 min. Maintain the full test load for a period of at least 24 h. Reduce the test load to the datum load for the necessary period (see 8.3.1). Take deflection measurements at A, B, C, and D (see Fig. 1).

NOTE 1—For plastic, corrugated paperboard, or honeycomb pallets, datum load levels of 100 to 200 lbf are recommended.

8.3.2.3 If because of the unavailability of a suitable testing machine, dead weights are used for the test load, they shall be symmetrically placed during loading and unloading. Dead weights shall be carefully placed, without dropping, within a 1 to 5-min loading period.

8.3.2.4 An alternative to the full pallet compression test is the test of an individual spacer as in block or post pallets or a portion of the spacer as in stringer pallets (see Fig. 2). The datum load shall be adjusted by the ratio of the bearing area of the individual spacers or portions of spacers tested and the bearing area of all spacers in the pallet. For non-uniform loading, only the most severely stressed spacers shall be tested.

8.3.2.5 The average of the deflections measured at A_1 and A_2 shall be used (see Fig. 2). When testing only a portion of the pallet, at least three tests shall be performed at different locations of the pallet, such as at A, B, and C in Fig. 2.

8.3.2.6 Observe and record any structural damage or failures. The pallet has failed the test if the observed damage in

any pallet tested would affect pallet stiffness, strength, or functionality. The rate of deformation is expected to decrease during the full-load static test.

8.3.2.7 During preliminary testing and to determine the preliminary safe working load R (see Table X2.1), this test shall be continued to a load level causing structural failure. In such a case, the failed pallet is no longer suitable for use in sequential testing.

8.4 Bending Tests on Pallet—The purpose of this test is to determine the flexural stiffness and strength of the whole pallet.

8.4.1 Test Loads—Typical representative loads (case goods, bagged goods, blocks, barrels, etc.) shall be used in pallet bending tests. Where various loads will be placed on pallets, that load type resulting in the greatest stress shall be used. When actual loads cannot be used, simulated loads are acceptable. Uniformly distributed case goods or bag loads are simulated using an inflatable bag or a tube restrained in a testing rig or by using a vacuum chamber.⁵ Concentrated loads on pallets are simulated with load applications exhibiting the same geometric interface between the load and the pallet deck as the actual in-service load.

8.4.2 Supports—Placement of rigid supports for pallet bending tests shall be based on the mode of support during use. When more than one mode of support is likely to occur, that which most limits the functionality of the pallet under load

⁵ Pallet device incorporating an inflatable dunnage bag is described in: Mackes, K. H., Loferski, J. R., and White, M. S., A Pneumatic Pressure Bag Testing Machine for Applying a Uniform Load to Panels and Pallets, *Journal of Testing and Evaluation*, Vol. 23, No. 4, 1995, pp. 295-299. A test device incorporating a vacuum chamber is described in: Dallas, J. E., and Mitzner, R. C., "Vacuum Loading Technique Increases Accuracy of Pallet Testing," Technical Note, *Forest Products Journal*, 1985, Vol. 27, pp 48-50.

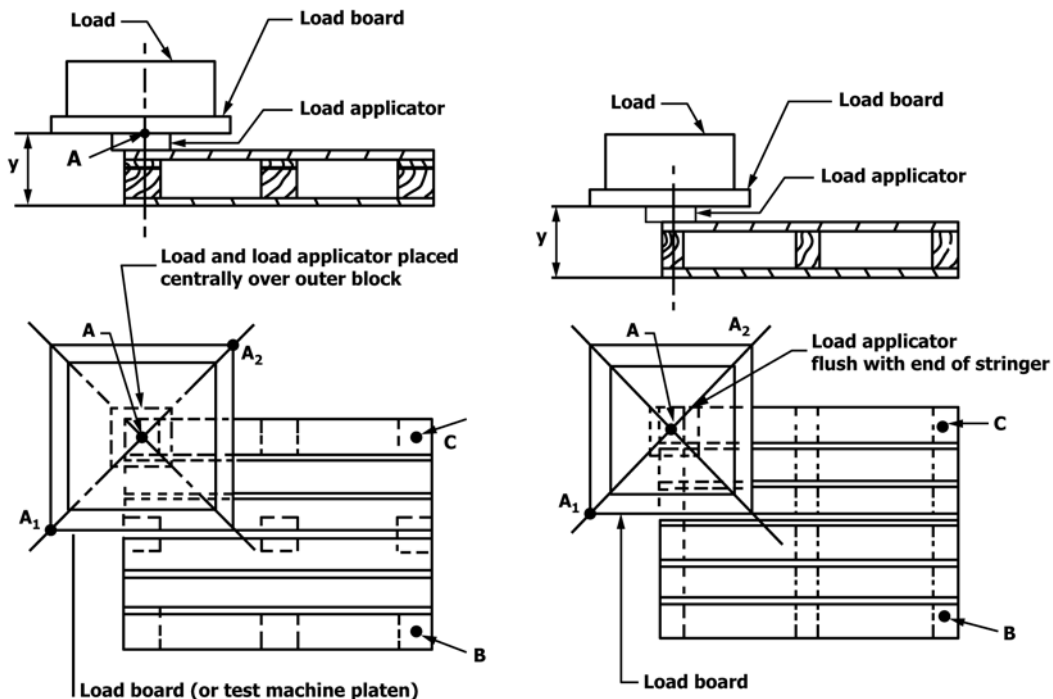

FIG. 2 Load Application and Deflection-Measurement Locations for Compression Tests of Individual Pallet-Deck Spacers or Portions of Spacers

shall be used for testing. That support which limits pallet functionality in bending shall be used which causes greatest deflection or structural failure at the lowest load levels. This is typically the support that results in the greatest unsupported free span. Support modes are shown in Fig. 3 and described as follows:

8.4.2.1 *Fork-Tine Support*—Under the top deck or in the stringer notch in stringer pallets.

8.4.2.2 *Rack Support*—Under the bottom deck or outside of the deck spacers in wing pallets.

8.4.2.3 *Sling Support*—Under the top deck, outside of the deck spacers such as in wing pallets. For sling tests, support modes shall be determined by the intended distribution cycle and the sling equipment used in that distribution environment. (Test devices may include wire, tape, or chain slings and rigid, round, or rectangular spreader bars.)

8.4.2.4 With the exception of very long or wide pallets, which exhibit large cantilevers beyond the supports, the rack mode generally represents the greatest span and corresponding deflection.

8.4.3 *Deformation Measurements*—When tested in accordance with the method specified in 8.4.4, the deflection at Locations A, B, and C, as shown in Fig. 4, when measured relative to the upper (or lower) surface of the top (or bottom) decks and the ground (or test frame), shall be observed and recorded as follows:

8.4.3.1 At the datum load (see 8.4.4),

8.4.3.2 Upon unloading, at the datum load (see 8.4.4), every 5 min until successive readings are practically identical (limited to a maximum period of 1 h).

8.4.3.3 The distance between the decks, h , at mid-span between deck spacers, measured in order to obtain data on the minimum fork entry heights under given loads.

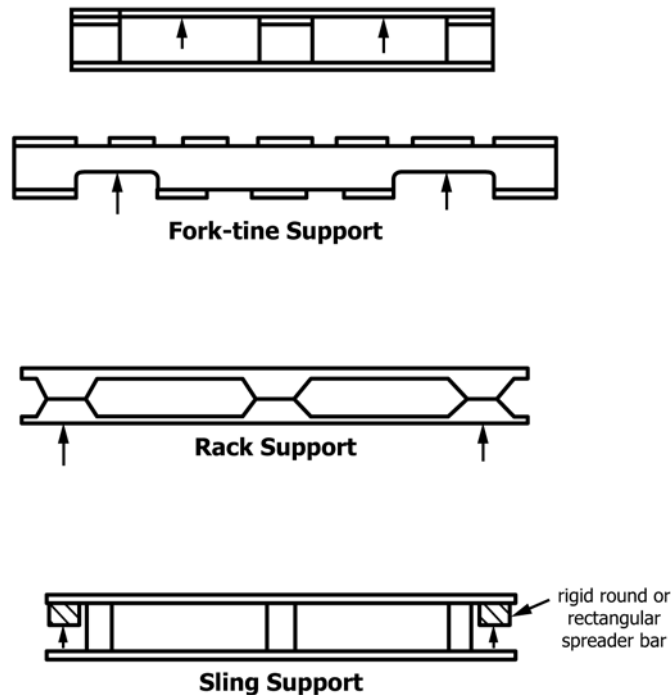

FIG. 3 Support Modes for Static Pallet-Bending Test

8.4.3.4 Between the decks, similar measurements made at Locations C, D, and E when the test is repeated along the second horizontal axis of the pallet (see 8.4.4).

8.4.4 *Test Procedure:*

8.4.4.1 For most pallets stressed in bending, the support mode which limits functionality is the rack support or the support under the bottom deck in double-face pallets or under the top deck in single-face pallets. Under these conditions of support, place the pallet top deck uppermost on rigid support beams with square or semicircular cross section. If the span between the supports is unknown, place the inside edges of the supports (or centerline in semicircular cross-section supports) 51 mm (2 in.) from the outer edges of the pallet (see Fig. 4).

8.4.4.2 Gradually apply the test load at a uniform rate from 0 to 0.1 R , where R is the preliminary safe working load per pallet and 0.1 R is the datum load for subsequent deflection measurements. Apply the full test load of 1.25 $\cdot M \cdot R$, where M is the maximum number of pallet loads expected when supported or tested. Maintain the full test load for a period of at least 24 h.

8.4.4.3 Reduce the test load to the datum load for the necessary period (see 8.4.3) and observe the deflection measurements at Locations A, B, and C (see Fig. 4).

8.4.4.4 If, because of the unavailability of a suitable testing machine, dead weights are used for the test load, they shall be symmetrically placed during loading and unloading. Dead weights shall be carefully placed, without dropping, and within a 1 to 5-min loading period.

8.4.4.5 Repeat the test along the second horizontal axis of the pallet (that is, when both length and width are to be tested). A further set of deflection measurements shall be taken at Locations C, D, and E. Observe and record any damage and structural failure. The pallet has failed the test if the observed damage in any pallet tested affects pallet stiffness, strength, or functionality. The rate of deformation is expected to decrease during the full-load static test.

8.4.4.6 During preliminary testing and to determine the preliminary safe working load R (see Table X2.1), this test shall be continued to a load level causing structural failure. In such a case, the failed pallet shall not be used for further testing.

8.5 *Bending Tests on Pallet Decks*—Under certain load and support conditions, the flexural stiffness and strength of the pallet top or bottom deck limits functionality. The purpose of this test is to determine the stiffness and flexural strength of pallet decks between supports.

8.5.1 *Deflection Measurements:*

8.5.1.1 When tested in accordance with 8.5.2, deflection shall be measured in a minimum of two locations at mid-span of the longest span between deck spacers, such as at Locations A, B, C, and D in Fig. 5, or at the location of the concentrated loads.

8.5.1.2 Measurements relative to the upper or lower surface of the deck and the opposite deck or the ground (or test frame), shall be recorded as follows:

- (1) At the datum load (see 8.5.2);
- (2) At the beginning and end of the full load period;

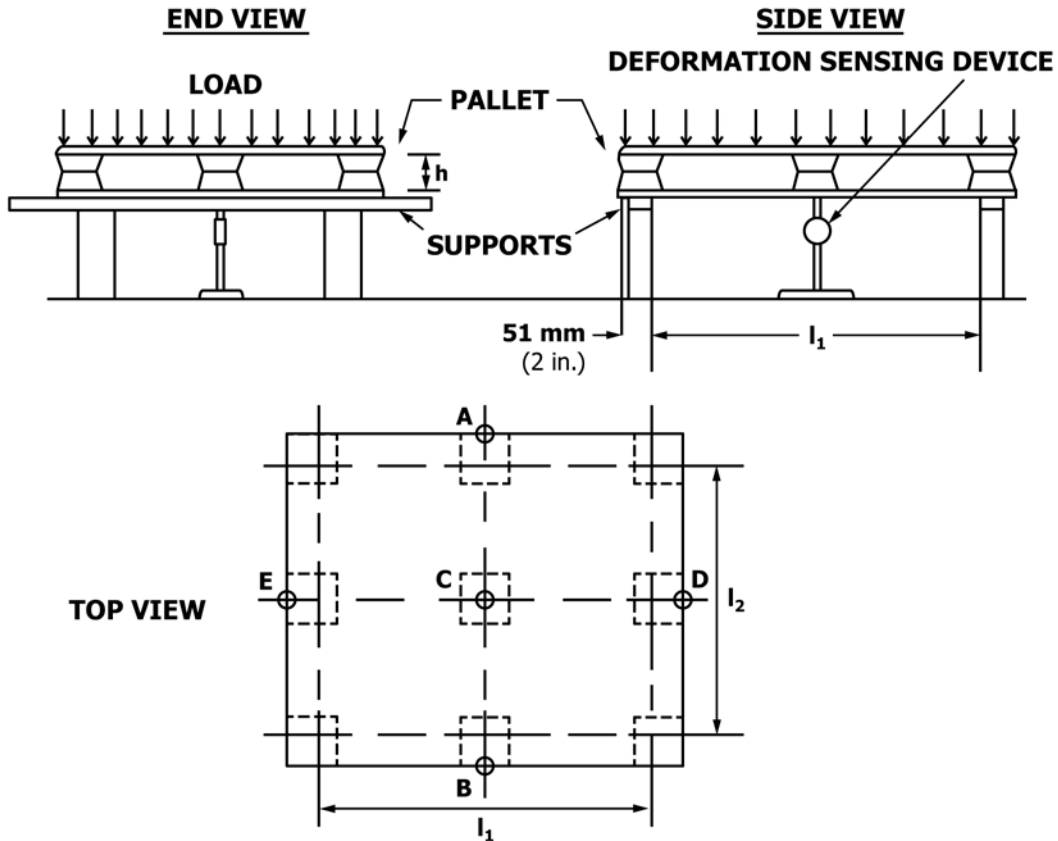

FIG. 4 Schematic Diagram of Pallet Bending Test Using Uniformly Distributed Load

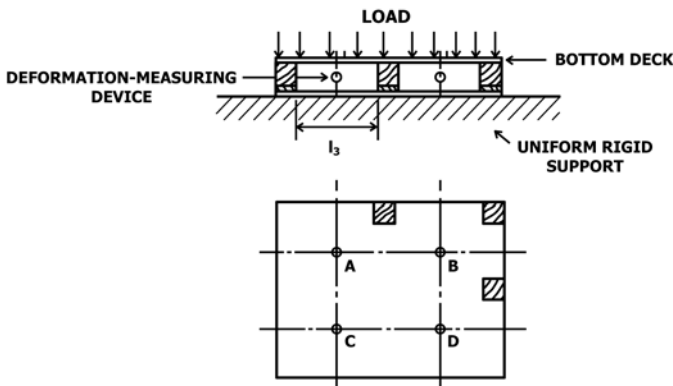

FIG. 5 Load and Support Conditions and Locations of Deflection Measurements for Bending Test of Pallet Decks

(3) Upon unloading, at the datum load (see 8.4.3), every 5 min until successive readings are practically identical:

8.5.2 Test Procedure:

8.5.2.1 Gradually apply the test load at a uniform rate from 0 to 0.1 R in a 1 to 5-min loading period. This shall be the datum load for subsequent deflection measurements. Apply the full test load of $1.15 \cdot M \cdot R$ for the top deck and $1.15 \cdot (M - 1) \cdot R$ for the bottom deck of non-reversible pallets, if load effects on pallets in the stack are cumulative, in not less than 1 min and not more than 5 min. R is the preliminary safe working load per pallet and M is the maximum number of pallet loads expected in a stack during use. The datum as well as the full test load

shall be applied in not less than 1 min or more than 5 min. Maintain the full test load in place for a period of at least 24 h.

8.5.2.2 Reduce the test load to the datum load for the necessary period (see 8.5.1) and take the deflection measurements at Locations A, B, C, and D. This test shall be repeated for both decks of a double-face pallet. Observe and record any damage or structural failures. The pallet has failed the test if the observed damage in any pallet tested affects pallet stiffness, strength, or functionality. The rate of deformation is expected to decrease during the test.

8.5.2.3 If, because of unavailability of a suitable testing machine, dead weights are used for the test load, they shall be symmetrically placed during loading and unloading. Dead weights shall be carefully placed, without dropping, and within a 2 to 5-min loading period.

8.5.2.4 During preliminary testing and the determination of the preliminary safe working load R (see Table X2.1), this test shall be continued to a load level causing structural failure. In such a case, the failed pallet shall not be used for further testing.

DYNAMIC TESTS

9. Summary of Test Method

9.1 Dynamic tests are performed to determine the stability of the pallet and unit load on the pallet when exposed to elements of the handling and shipping environments. These tests shall be sequentially performed in the order described and

each represents one hazard element. A hazard element is a specific event that occurs in the distribution cycle that may pose a hazard to the pallet and the unit load. If any deviations are made from this sequence to meet specific requirements or limitations, they shall be indicated and explained in the report.

9.2 For the dynamic tests described in 9.5, the test load applied shall include the actual package systems unitized similar to the expected unit load. In the case where representative actual products cannot be used, dummy products that are similar in size and weight shall be used. However, the packaging used shall be identical to that of real loads, since the dynamics of the unit load is affected if a dead load representing the total pallet load is placed on the pallet base. The performance criteria in X2.2 of Appendix X2 may be used to classify pallets as single- or multiple-use (see 1.2.1 and 1.4).

9.3 *Free-Fall Drop Tests on Pallet Corners and Edges along Pallet Ends and Sides*—The purpose of these tests is to determine the resistance to impacts of the pallets, including its decks and blocks, as a result of free-fall pallet drops during handling. Such drops occur during unstacking or removal of pallets. For those non-rigid pallets which may deform as a result of dropping, this test can be used to measure the relative diagonal pallet rigidity (see 9.3.1).

9.3.1 Test Procedure:

9.3.1.1 Subject the pallet to free-fall drops from a fixed height of 1.0 m (40 in.). Conduct drops using a suitable suspension device (such as a hoist) to allow accurate positioning of the suspended pallet and a solenoid or other drop-test release mechanism. Make all drops onto a rigid, massive block of concrete, steel, or other suitable dense material, having a smooth, level, and hard surface.

9.3.1.2 Ensure that the pallet is suspended in such a manner that (1) the diagonal across each pallet face from the suspension corner to the impact corner is vertical; and (2) the pallet corner, that is the line at the intersection of the pallet end and side, is parallel with the surface onto which the pallet is dropped.

9.3.1.3 During the drop tests on the pallet end and side edges, drop the pallet on the weaker pallet edges along the pallet top deck and bottom deck if the top-deck design differs from the bottom-deck design.

9.3.1.4 Perform six drops in the following sequence:

Number of Drops	Impact Surface
Three	pallet corner (see Fig. 6)
One	adjacent pallet corner
One	pallet end edge (see Fig. 7)
One	pallet side edge

9.3.1.5 In non-rigid pallet designs, the deformation of the top-deck and bottom-deck pallet diagonals shall be measured after each of the three initial drops. Care shall be taken that each drop represents one impact. Because pallets vary in size and weight, the average amount of deformation in diagonals shall be expressed as a ratio of the deformation in the diagonal to the original length of the pallet diagonal prior to testing. Observe and record any damage or structural failures.

9.3.1.6 When a second series of tests is specified to simulate additional handling operations, make the additional drops onto

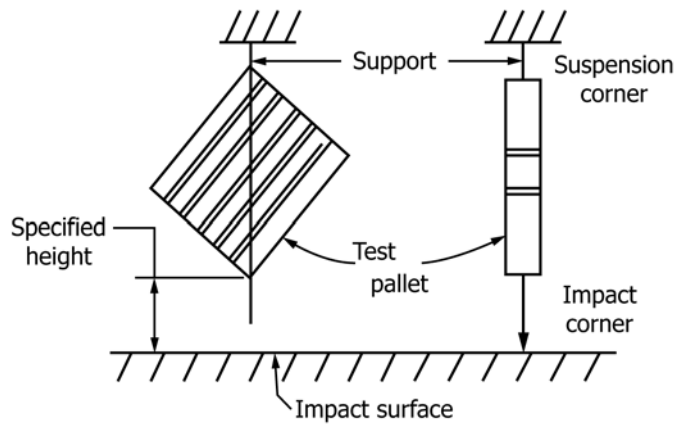

FIG. 6 Corner Drop of Vertically Suspended Pallet

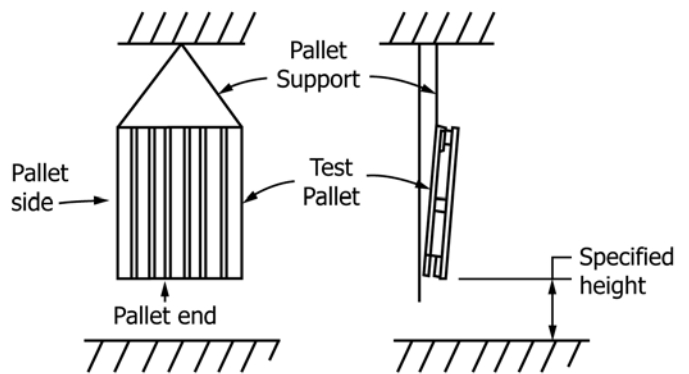

FIG. 7 End Drop of Vertically Suspended Pallet

the remaining two pallet corners and two pallet ends and pallet sides not previously tested.

9.3.1.7 The pallet has failed the test if the observed damage in any pallet tested affects pallet rigidity, strength, or functionality.

9.4 *Incline Impact Tests on Pallet Deck Edges, Blocks or Posts, and Stringers*—The purpose of these tests is to determine the resistance of the pallet and its components (deckboard, blocks, and stringers) to impact forces resulting from interaction with a variety of material handling equipment, such as forklift trucks and pallet jacks. These tests simulate impact conditions resulting from the following conditions:

9.4.1 Fork heel impacts when the fork heels of the forklift truck impact the pallet deck edges;

9.4.2 Fork impact when the tip of misaligned forks strike the corner post or stringer on entry;

9.4.3 Fork-tine tip pressure, which causes pallets to collapse horizontally.

9.4.4 Test Equipment:

9.4.4.1 The testing device shall consist of a guided test carriage with a flat pallet mounting surface and an impact surface (backstop) with the plane of the face perpendicular within $\pm 1/2^\circ$ to the direction of movement of the carriage at impact (see Note 2).

9.4.4.2 There shall be an impact surface (backstop) that is integral with a solid mass at least 50 times the maximum mass of the loaded pallet. The impact surface, firmly attached to this

mass, shall be a steel plate not less than 13 mm (½ in.) thick. The impact surface (backstop) shall have dimensions greater than those of the impacting surface of the pallet to permit full contact with the pallet (see Note 2).

NOTE 2—The intent is to provide an impact surface (backstop) and mass which improve the accuracy of tests within and between laboratories and the interlaboratory correlation of the test results.

9.4.4.3 The testing device shall provide some means of moving the test carriage to obtain the desired impact velocity. This is accomplished as a result of gravity through the use of a 10° incline (see Note 3).

NOTE 3—An alternative testing device is described in Methods D4003, requiring the use of mechanical or pneumatic means to move the test carriage in a horizontal direction (see 9.4.7). A calibration certificate shall be appended to the test report. Depending on the configuration of the testing device, there can be other forces acting before, during, or after the impact which affect the test results.

9.4.4.4 The testing device shall provide a means of preventing multiple impacts. The test carriage shall provide such surface friction or a mechanical device preventing the test pallet from moving until impact has occurred, but not from moving freely upon impact.

9.4.4.5 The impact surface (backstop) shall be equipped with hazards representing the fork tips described in Fig. 8, to perform the impacts on the leading edge. Fig. 9 describes the test setup for performing these tests. Fig. 10 describes the test hazard used for the test of collapse resistance. Fig. 11 describes the hazard used for the fork-tine tip impact resistance test. These hazards shall be placed in such a manner as to contact the pallet at any desired location of the leading-edge deckboard, block, or stringer.

9.4.5 *Weight Box*—The weight box shall be of a width equal to the pallet dimension perpendicular to direction of travel; however, 400 mm (16 in.) shorter than the pallet dimension parallel to the direction of travel. The weight box shall be loaded with a suitable number of weights. If no overall weight is specified, the test shall be conducted using a total weight of 500 lbf (2250 N).

9.4.6 *Instrumentation*—Instrumentation, consisting of either optical or mechanical timing devices, is required to measure the carriage impact velocity to an accuracy of ±2 % of the actual value. When testing is performed within a laboratory and for comparative purposes only, use of such instrumentation is optional.

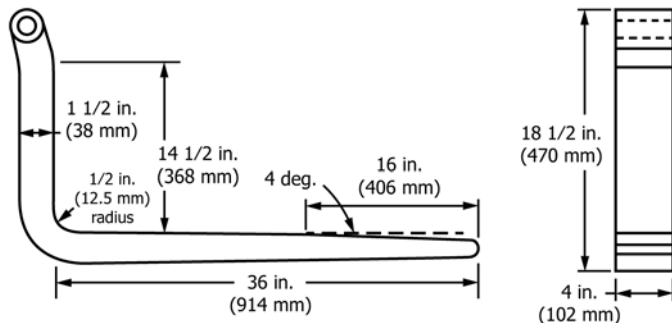

FIG. 8 Standard Fork Used for Leading-Edge Deck-Board-Separation Impact Test

9.4.7 *Test Procedure:*

9.4.7.1 Position the loaded carriage in such a manner that the predetermined impact velocity will be obtained at impact. Release the loaded carriage. Measure the impact velocity of each test to ensure that it is representative of the desired impact velocity.

9.4.7.2 The sequence in which the faces and edges are subjected to impacts depends on the objectives of the test and needs to be specified. The impacts shall be performed using an impact speed of 50 in./s (1270 mm/s). Use the following sequence to perform the impacts:

Number of Impacts	Impact Test Condition
Two	leading-edge fork-heel impact
Two	fork-toe and slue resistance
Two	lead-edge deckboard separation resistance

9.5 *Vibration Tests on Loaded Pallet*—The purpose of these tests is to determine the resistance of the pallet (deck, blocks, and posts) to vibration forces resulting from the use of a variety of transport systems. In addition, the tests are used to determine the effect of pallet design on unit load stability and the fundamental (first mode) resonant frequency of the unit load.

9.5.1 *Test Procedure*—The vibration tests shall be performed with the vibration test equipment described in Methods D999, Method C. Place the pallet in the normal position onto the vibration table. The packages shall be stacked and unitized on the pallet top in the anticipated shipping manner.

9.5.1.1 In the case where representative actual products cannot be used, dummy products shall be used that have similar weight and size characteristics. The packaging and dunnage used shall be similar to those designed for the actual product. A dead load or equivalent mass replicating the pallet load shall not be used, since this would result in different dynamics of the system. The pallets shall be tested by the described methods to determine their vibration characteristics.

9.5.2 *Method A—Pallet Load Resonance Test:*

9.5.2.1 This test covers the effect of pallet design on unit load resonance. The test is repeated using a palletized load and load without a pallet. Place the load or palletized load on the vibration table as described in 9.5.1. Attach restraining devices to prevent the load or palletized load from traveling on the table and excessive rocking. Adjust the restraining devices to permit free movement of the load for approximately 25 mm (1 in.) in any horizontal direction. If use of instrumentation is required, place an accelerometer on the top of the pallet load to determine transmissibility levels.

9.5.2.2 Start the vibration of the table at a frequency of 3 Hz, with a constant acceleration level of 0.25 to 0.50 g. Steadily increase the frequency at a continuous logarithmic rate of approximately 0.5 octaves per minute to the upper frequency limit of 100 Hz. Sweep back to the lower frequency and repeat this procedure twice, recording all resonant responses to the pallet load (Note 4).

NOTE 4—Resonant frequencies provide important information to understand the stability of the load when exposed to a variety of transport systems.

9.5.2.3 Dwell for the specified length of time at each resonant frequency until damage occurs or the unit load

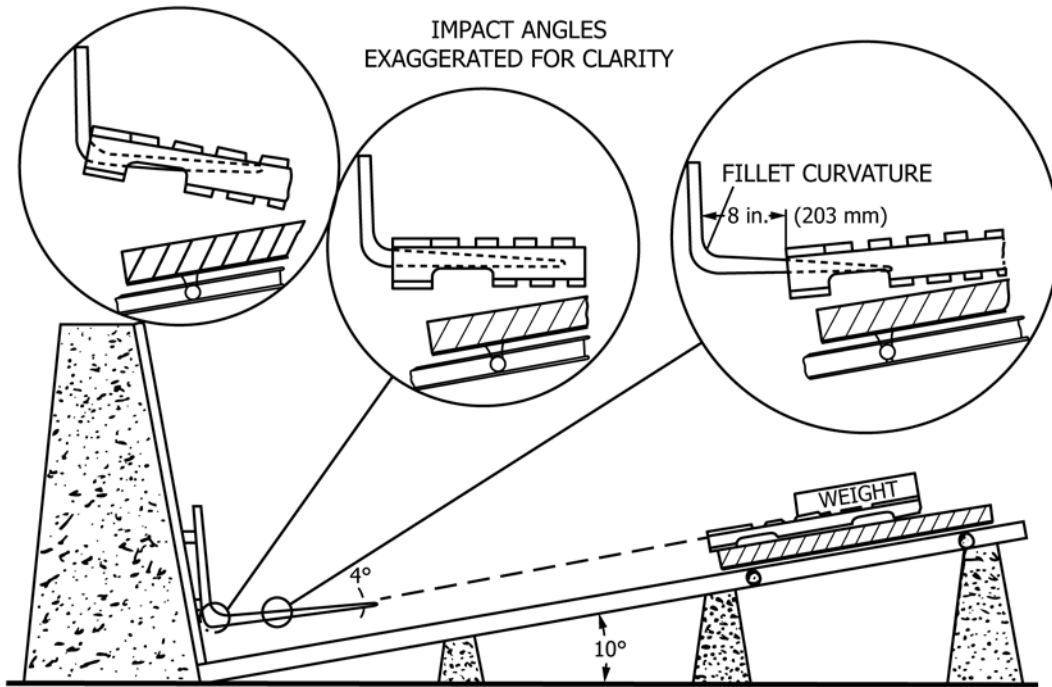

NOTE 1—An alternative testing device is that which uses mechanical or pneumatic means to move the test carriage in a horizontal plane, resulting in the required impact speed (see Note 3). A calibration certificate to this effect shall be appended to the test report.

FIG. 9 Test Setup for Determination of Incline-Impact Resistance of Leading-Edge Deckboard of Pallet

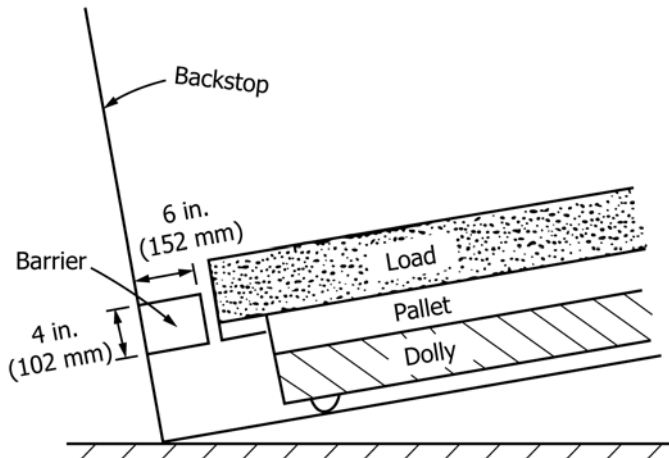

FIG. 10 Hazard Used for Impact Testing of Collapse Resistance

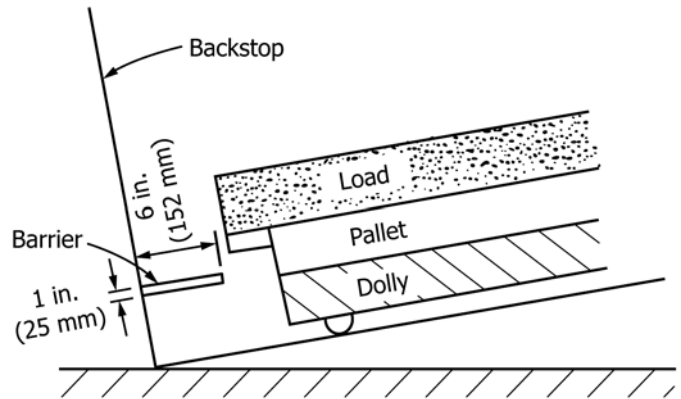

FIG. 11 Hazard Used for Fork-Tine Tip Impact Resistance

becomes unstable. If no particular dwell time is specified, a dwell of 30 min shall be used.

9.5.2.4 Inspect the pallet and load and record any damage to the load, its stability, and any deterioration of the pallet structure.

9.5.2.5 Compare the results of palletized and non-palletized tests and determine the effect of the pallet design. Observe and record any damage or structural failures. The pallet failed the test if the observed damage in any pallet tested affects pallet stiffness, strength, or functionality.

9.5.3 Method B—Pallet Load Random Vibration Test:

9.5.3.1 This test covers the effect of pallet design on the unit load exposed to random vibration levels encountered in a variety of transport systems. The test is performed on the

palletized load and load without pallet. Place the palletized or non-palletized load on the vibration table as described in 9.3.1. Attach restraining devices to prevent the palletized or non-palletized load from traveling on the table and excessive rocking. Adjust the restraining devices to permit free movement of the load for approximately 25 mm (1 in.) in any horizontal direction. If use of instrumentation is required, place an accelerometer on the top of the pallet load to determine transmissibility levels. The response acceleration-time history shall be recorded to allow analysis of the response power density spectrum.

9.5.3.2 Program the required power density spectrum that replicates a given transport or material handling system. Start the vibration of the table using a random controller as described in Test Method D4728. If no particular random

vibration spectrum is specified, use Test Method **D4728** recommended spectrums for various transportation methods.

9.5.3.3 Dwell on the specified length of time at each power density spectrum used to simulate the transport methods until damage occurs or the unit load becomes unstable. If no particular dwell time is specified, a dwell time of 1 h shall be used.

9.5.3.4 Inspect the pallet load and record any damage to the load, its stability, and any deterioration of the pallet structure.

9.5.3.5 Compare the results of testing palletized and non-palletized load to determine the contribution of the pallet to unit load performance. Observe and record any damage or structural failures. The pallet failed the test if the observed damage in any pallet tested affects pallet stiffness, strength, or functionality. (**Warning**—These tests produce strong mechanical responses of the pallet loads. Therefore, any fences, barricades, and other restraints shall have sufficient strength and shall be adequately secured. Operating personnel shall remain alert to the potential hazards and take necessary precautions for their safety. Stop the test immediately when a dangerous condition develops.)

10. Report of Pallet Testing

10.1 Report the following information, if applicable:

10.1.1 Date of test and date of report.

10.1.2 Test sponsor and test agency.

10.1.3 Identification of pallet or related structure; manufacturer, model design, size, style, type, and weight; materials and finish; pretest conditioning; dimensions, fasteners and their location; and other pertinent information as well as observations such as cracks, splits, and other defects.

10.1.4 Detailed drawings or photographs of typical test assemblies before, during, and after testing, if not otherwise fully described.

10.1.5 Relevant physical and mechanical properties of the materials used in pallet fabrication (that is, density, moisture content, elastic moduli, etc.).

10.1.6 Description of the procedure used for the fabrication of the pallets.

10.1.7 Description of test equipment and instrumentation used including appropriate calibration certificates.

10.1.8 Information on time between conditioning and testing, if this information is of any significance.

10.1.9 Description of test method and loading procedure.

10.1.10 Total amount of weights used in impact test, the impact velocity, and the number of impacts performed.

10.1.11 Number of replicate specimens tested.

10.1.12 All test data, including their statistical analysis, to provide mean deflection and load values, in millimeters (in.) and newtons (lbf), respectively, and standard deviations.

10.1.13 Resonant frequencies present and dwell times used.

10.1.14 Random spectra and dwell times used.

10.1.15 Relevant test limitations, test performance criteria, and detailed description of observed damage or structural failure for each pallet tested.

10.1.16 Recommendations.

10.1.17 Listing of observers of tests and signatures of responsible persons.

10.1.18 Summary of findings.

11. Precision and Bias

11.1 *Precision*—Based on limited data from one laboratory, the within laboratory repeatability precision is given here as a coefficient of variation, the standard deviation divided by the average. When sample to sample variation can be eliminated, the residual testing variation is about 5 % of the mean for these methods. Sample to sample variation, which often cannot be separated from testing variation, can increase the observed coefficient of variation to 15 to 30 %. Sufficient data on the between laboratory reproducibility are not available at this time.

11.2 *Bias*—The methods described in D1185 have no reportable bias because a true reference value cannot be determined by an accepted referee test method.

12. Keywords

12.1 pallet; performance; testing

APPENDIXES

(Nonmandatory Information)

X1. RELATED STANDARDS AND PUBLICATIONS

X1.1 ISO Standards and Technical Reports³

ISO 8611 General-Purpose, Flat Pallets for Through Transit of Goods – Test Methods, and Amendment 1

ISO TR 10232 General-Purpose Flat Pallets for Through Transit of Goods – Design Rating and Maximum Working Load

ISO TR 10233 General-Purpose Flat Pallets for Through Transit of Goods – Performance Requirements

ISO 6780 General-Purpose Flat Pallets for Through Transit of Goods, Principal Dimension and Tolerances

X1.2 ANSI/ASME Standards³

MH1 Pallets, Slipsheets, and Other Bases for Unit Load
MH1.6 Standard Procedures for Determination of Durability of Wooden Pallets and Related Structures

MH1.7M Driven Fasteners for Assembly of Pallets and Related Structure

MH1.8 Wood Pallets

MH1.9 Export Pallets

TABLE X2.1^A

Static Tests	Test Load Level	Maximum Allowable Deformation after 2 h under test load	Maximum Residual Deformation after 1 h recovery at datum load
Compression tests of deck spacers (see 8.3 and Figs. 1 and 2)	(1.1) (M) ^B (R) ^C	0.160 in. (4 mm)	0.06 in. (1.6 mm)
Bending tests on pallets (see 8.4 and Fig. 4)	(1.25) (M) ^B (R) ^C	0.019×L ₁ or L ₂ ^D	0.0075×L ₁ or L ₂ ^D
Bending tests on pallet decks (see 8.5 and Fig. 5)	Top deck (1.1) (M) ^B (R) ^C	0.015×L ₃ ^E	0.0053×L ₃ ^E
	Bottom deck (1.1)(M ^B -1)(R) ^C	0.015×L ₃ ^E	0.0053×L ₃ ^E

^A Under some conditions of use, such as in automatic storage facilities and equipment, maximum permissible deflections may be less than those specified in this Table.

^B M is the maximum number of unit loads stacked one on top of another during pallet use.

^C R is a preliminary safe working load which is the average failure load adjusted to an appropriate safety level. For wood pallets, a common adjustment factor is 0.35.

^D When supporting pallets under the top deck, the span between supports or overhang of the supports representing the largest deformation shall be used.

^E L₃ is the longest span between deck spacers.

X1.3 GSA-FSS Standard⁶

PPP-P-1660 Federal Specification: Pallet, expendable

⁶ Available from U.S. Government Printing Office Superintendent of Documents, 732 N. Capitol St., NW, Mail Stop: SDE, Washington, DC 20401, <http://www.access.gpo.gov>.

X1.4 ANSI/CGATS³

CGATS-7 Graphic Technology—Pallet Loading for Printed Materials

X2. PALLET PERFORMANCE TEST CRITERIA

X2.1 Static Tests

X2.1.1 *Compression Tests of Deck Spacers* (see 8.3 and Figs. 1 and 2)—The change in deformation “y” shall not exceed 0.16 in. (4 mm) under test load. The change in “y” shall not exceed 0.06 in. under the 0.10 R datum load and recovery shall be attained within 1 h (see Table X2.1).

X2.1.2 *Bending Tests on Pallets* (see 8.4 and Fig. 4)—The rate of deformation shall decrease during the test. In addition, the average deformation shall not exceed 0.019×L₁ or L₂ measured in relation to the deformation at the 0.1R datum load (see Table X2.1).⁷ In pallets having both top and bottom decks, the spacing between the decks “h” shall not be less than 3.32 in. (84 mm) under the full test load.

X2.1.3 *Bending Tests on Pallets Decks* (see 8.5 and Fig. 5)—The rate of deformation shall decrease during the test. In

⁷ White, M.S., “The Effect of Load Applicators on the Bending Strength and Stiffness of Wood Pallets Using Procedures Described in ISO 8611,” Department of Wood Science and Forest Products, 1993, Virginia Tech, Blacksburg, VA.

addition, the average deformation shall not exceed 0.015×L₃ measured in relation to the deformation at the 0.1R datum load (see Table X2.1).

X2.1.3.1 Recovery shall be attained within 1 h to a value not exceeding 0.0053×L₃ measured under the 0.1 R datum load.

X2.2 Dynamic Tests

X2.2.1 Limited-use pallets shall survive at least one (1) cycle in each of the successive tests. Multiple-use pallets shall survive at least ten (10) cycles in each of the successive tests.

X2.2.2 Damage levels which limit survivability are permanent deformations which exceed those specified in X2.1.1 and X2.1.3 or damages which significantly reduce pallet structural strength or functionality. Such damage levels are for wood pallets described in ASME/ANSI MH1. The weight of the load box and its contents, used in incline impact tests (see 9.2), shall be the rated load of the pallet or 2250 N (500 lbf) or whichever is less.

ASTM International takes no position respecting the validity of any patent rights asserted in connection with any item mentioned in this standard. Users of this standard are expressly advised that determination of the validity of any such patent rights, and the risk of infringement of such rights, are entirely their own responsibility.

This standard is subject to revision at any time by the responsible technical committee and must be reviewed every five years and if not revised, either reapproved or withdrawn. Your comments are invited either for revision of this standard or for additional standards and should be addressed to ASTM International Headquarters. Your comments will receive careful consideration at a meeting of the responsible technical committee, which you may attend. If you feel that your comments have not received a fair hearing you should make your views known to the ASTM Committee on Standards, at the address shown below.

This standard is copyrighted by ASTM International, 100 Barr Harbor Drive, PO Box C700, West Conshohocken, PA 19428-2959, United States. Individual reprints (single or multiple copies) of this standard may be obtained by contacting ASTM at the above address or at 610-832-9585 (phone), 610-832-9555 (fax), or service@astm.org (e-mail); or through the ASTM website (www.astm.org). Permission rights to photocopy the standard may also be secured from the Copyright Clearance Center, 222 Rosewood Drive, Danvers, MA 01923, Tel: (978) 646-2600; <http://www.copyright.com/>