



Standard Test Method for Ductility of Bituminous Materials¹

This standard is issued under the fixed designation D113; the number immediately following the designation indicates the year of original adoption or, in the case of revision, the year of last revision. A number in parentheses indicates the year of last reapproval. A superscript epsilon (ϵ) indicates an editorial change since the last revision or reapproval.

This standard has been approved for use by agencies of the U.S. Department of Defense.

1. Scope

1.1 This test method describes the procedure for determining the ductility of a bituminous material measured by the distance to which it will elongate before breaking when two ends of a briquet specimen of the material, of the form described in Section 4, are pulled apart at a specified speed and at a specified temperature. Unless otherwise specified, the test shall be made at a temperature of $25 \pm 0.5^\circ\text{C}$ and with a speed of $5 \text{ cm/min} \pm 5.0 \%$. At other temperatures the speed should be specified.

1.2 Because of the large number of methods for obtaining test samples, it is impractical to discuss specific products in this test method. Refer to individual product specifications for guidance in obtaining a test sample.

1.3 The values stated in SI units are to be regarded as the standard. Values in parenthesis in inch-pound units are provided for informational purposes only.

1.4 **Warning**—Mercury has been designated by EPA and many state agencies as a hazardous material that can cause central nervous system, kidney and liver damage. Mercury, or its vapor, may be hazardous to health and corrosive to materials. Caution should be taken when handling mercury and mercury containing products. See the applicable product Material Safety Data Sheet (MSDS) for details and EPA's website (<http://www.epa.gov/mercury/faq.htm>) for additional information. Users should be aware that selling mercury or mercury containing products, or both, in your state may be prohibited by state law.

1.5 *This standard does not purport to address all of the safety concerns, if any, associated with its use. It is the responsibility of the user of this standard to establish appropriate safety and health practices and determine the applicability of regulatory limitations prior to use.*

2. Referenced Documents

2.1 ASTM Standards:²

- C670 Practice for Preparing Precision and Bias Statements for Test Methods for Construction Materials
- D5 Test Method for Penetration of Bituminous Materials
- D1754 Test Method for Effects of Heat and Air on Asphaltic Materials (Thin-Film Oven Test)
- D2872 Test Method for Effect of Heat and Air on a Moving Film of Asphalt (Rolling Thin-Film Oven Test)
- E1 Specification for ASTM Liquid-in-Glass Thermometers
- E11 Specification for Woven Wire Test Sieve Cloth and Test Sieves
- E77 Test Method for Inspection and Verification of Thermometers
- E220 Test Method for Calibration of Thermocouples By Comparison Techniques
- E644 Test Methods for Testing Industrial Resistance Thermometers

3. Significance and Use

3.1 This test method provides one measure of tensile properties of bituminous materials and may be used to measure ductility for specification requirements.

4. Apparatus

4.1 **Mold**—The mold shall be similar in design to that shown in Fig. 1. The mold shall be made of brass, $10.0 \pm 0.1 \text{ mm}$ thick, the ends b and b' being known as clips, and the parts a and a' as sides of the mold, with a brass base plate that is larger than the assembled mold. The dimensions of the assembled mold shall be as shown in Fig. 1 with the permissible variations indicated.

4.2 **Water Bath for Conditioning Specimens**—A water bath capable of maintaining the specified test temperature, varying

¹ This test method is under the jurisdiction of ASTM Committee D04 on Road and Paving Materials and is the direct responsibility of Subcommittee D04.44 on Rheological Tests.

Current edition approved Dec. 1, 2007. Published January 2008. Originally approved in 1921. Last previous edition approved in 1999 as D113 – 99. DOI: 10.1520/D0113-07.

² For referenced ASTM standards, visit the ASTM website, www.astm.org, or contact ASTM Customer Service at service@astm.org. For *Annual Book of ASTM Standards* volume information, refer to the standard's Document Summary page on the ASTM website.

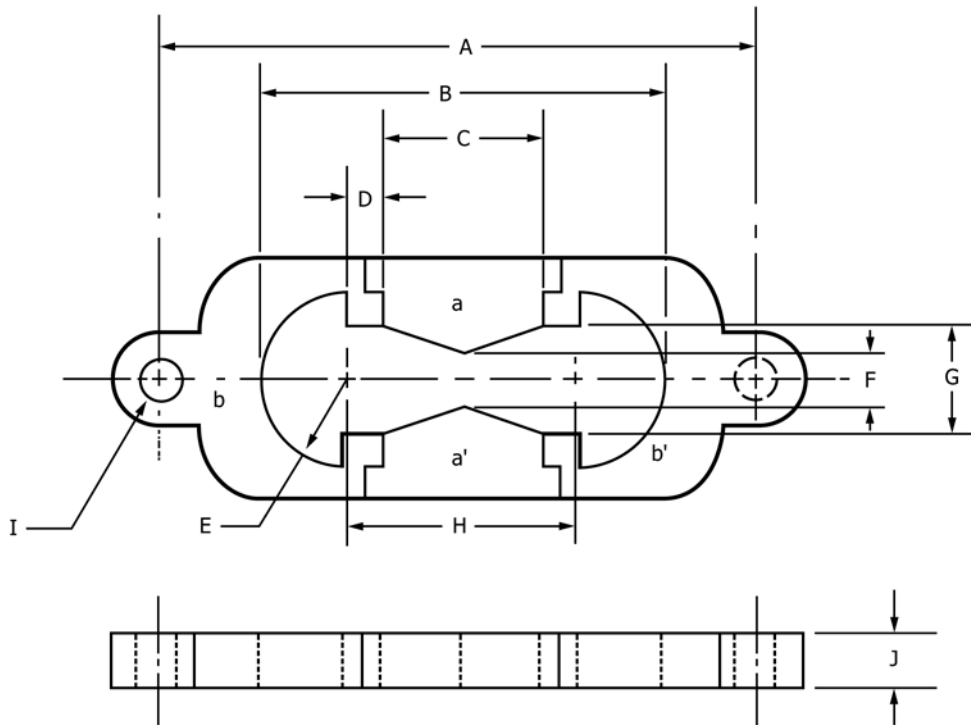

- A—Distance between centers, 111.5 to 113.5 mm.
- B—Total length of briquet, 74.5 to 75.5 mm.
- C—Distance between clips, 29.7 to 30.3 mm.
- D—Shoulder, 6.8 to 7.2 mm.
- E—Radius, 15.75 to 16.25 mm.
- F—Width at minimum cross section, 9.9 to 10.1 mm.
- G—Width at mouth of clip, 19.8 to 20.2 mm.
- H—Distance between centers of radii, 42.9 to 43.1 mm.
- I—Hole diameter, 6.5 to 6.7 mm.
- J—Thickness, 9.9 to 10.1 mm.

FIG. 1 Mold for Ductility Test Specimen

not more than 0.5°C (0.9°F) from this temperature. The specimen shall be immersed and supported such that it is surrounded by water.

4.3 *Testing Machine*—For pulling the briquet of bituminous material apart, any apparatus may be used which is so constructed that the specimen will be continuously immersed in water, while the two clips are pulled apart at a uniform speed, as specified, without undue vibration. A variation of $\pm 5\%$ is permissible. The water in the tank of the testing machine shall cover the specimen both above and below it by at least 2.5 cm and shall be maintained within $\pm 0.5^\circ\text{C}$ ($\pm 0.9^\circ\text{F}$) of the test temperature. The testing machine shall incorporate a means by which the elongation at the time of rupture can be measured in centimeters.

4.4 *Thermometer*—A thermometer having a range shown as follows, and conforming to the requirements in accordance with Specification E1 (Note 1). An equivalent thermometric device that has been calibrated in accordance with Test Method E220 or Test Methods E644 may be used.

Temperature Range	ASTM Thermometer No.
-8 to 32°C	63C
18 to 89°F	63F

4.5 *Release Agent*—A mixture such as glycerin and Dextrin, talc or Kaolin (china clay) or Versamid Resin and mineral oil used to coat the bottom and sides of mold to prevent the specimen from sticking to the mold. Other materials may be used for this purpose if they have been shown not to affect the physical properties of the test specimen.

4.6 *Oven*—An oven capable of maintaining within $\pm 5^\circ\text{C}$ ($\pm 10^\circ\text{F}$) of the temperature required to heat the sample so it is just fluid enough to pour.

4.7 *Trimming Tool*—A straight-edged putty knife or spatula wider than the specimen for trimming.

4.8 *Specific Gravity Additive*—A substance such as methyl alcohol, sodium chloride or ethylene glycol used to adjust the specific gravity of the water bath to prevent specimen from coming to the surface of the water or touching the bottom of the bath. Other additives may be used if they have been shown not to affect the physical properties of the specimen.

4.9 *Sieves*—A 300- μm (No. 50) sieve, in accordance with specification E11.

NOTE 1—In those cases where the ductility specimens are conditioned in the standard penetration bath at 25°C, the thermometer or equivalent thermometric as prescribed for Test Method D5 may be substituted in place of the above.

5. Procedure

5.1 Assemble the mold on a brass plate. Coat the surface of the plate and interior surfaces of the sides *a* and *a'*, Fig. 1, of the mold with a thin layer of a mixture of release agent. The plate upon which the mold is placed shall be flat and level so that the bottom surface of the mold will be in contact throughout. Carefully heat the sample to prevent local overheating until it has become sufficiently fluid to pour. After a thorough stirring, pour it into the mold. In filling the mold, take care not to disarrange the pieces of the mold, thus distorting the specimen shape. Pour the material in a thin stream back and forth from end to end of the mold until the mold is more than level full. Allow the filled mold to cool to room temperature for 35 ± 5 min. Then place it in the water bath at test temperature for 35 ± 5 min. Remove the test specimens from the water bath and immediately trim the excess material with the trimming tool to make the molds just level full.

NOTE 2—It is recommended to the user of this standard that all emulsified asphalt residues and cutback asphalt residues be sieved through a 300 μm (No. 50) screen prior to pouring test specimens. The current distillation procedures subject these materials to temperature conditions that will not be achieved in the field, and particulate matter may develop in the sample residues that may drastically (and negatively) affect the test results. If the material is sieved prior to testing, that notation should be included in the report.

5.2 *Keeping Specimen at Standard Temperature*—Place the trimmed specimen and mold in the water bath at the specified temperature for 90 ± 5 min. Remove the specimen from the plate by a shearing action between specimen and plate, avoiding any bending of the specimen. Remove the side pieces *a* and *a'* being careful not to distort or fracture the specimen.

5.3 *Testing*—Attach the rings at each end of the clips to the pins or hooks in the testing machine and pull the two clips apart at a uniform speed as specified until the specimen ruptures or reaches the length limitations of the testing machine. Measure the distance in centimetres through which the clips have been pulled to produce rupture or final length.

6. Report

6.1 A normal test is one in which the material ruptures near the center of the specimen or reaches the length limitations of

the testing machine. A rupture occurring at either clip shall not be considered normal.

6.2 If the bituminous material comes in contact with the surface of the water or the bottom of the bath, the test shall not be considered normal. Adjust the specific gravity of the bath by using a specific gravity additive as described in Section 4.8 so that the test specimen neither comes to the surface of the water, nor touches the bottom of the bath at any time during the test.

NOTE 3—Some additives used to adjust the specific gravity of the water bath are toxic and can cause corrosion of the testing machine. If specific gravity adjustments have been made it is recommended to wear gloves when placing hands in the bath fluid. Frequent bath fluid changes are recommended to prevent damage to the testing machine.

6.3 Report a normal test as the ductility of the sample. If a normal test is not obtainable, report the ductility as being unobtainable under the conditions of the test. If rupture does not occur due to length limitations of the testing machine, report ductility as the length limitation in cm+ (for example, 150 cm+). If this testing is performed on less than three replicates of the same sample due to insufficient material, include the number of replicates used in the test report.

6.4 In the event of a discrepancy, the referee method shall be to perform the test using three replicates. If the discrepancy involves a distillation residue, pour the material through a 300- μm (No. 50) sieve that has been preheated at $135 \pm 5^\circ\text{C}$ ($275 \pm 10^\circ\text{F}$) prior to pouring into test molds. Report the average of three normal tests as the ductility of the sample.

7. Precision and Bias

7.1 Criteria for judging the acceptability of ductility test results at 25°C (77°F) obtained by this test method are shown in Fig. 2.

NOTE 4—The precision statement for ductility, as presented in Fig. 2, is based on tests performed on asphalt cements. The precision of tests on residues, such as those obtained by Test Methods D1754 and D2872, have not been established.

NOTE 5—The numbers plotted in Fig. 2 represent the (1S) and (D2S) limits for single operator precision and multilaboratory precision as described in Practice C670.

NOTE 6—Insufficient data are available to properly define precision at 15.6°C. However, analysis of data resulting from tests by 13 laboratories on one asphalt for which the average ductility test result was 45 cm shows a multi-laboratory precision (D2S) of 23 cm.

8. Keywords

8.1 ductility; ductility mold; ductilometer

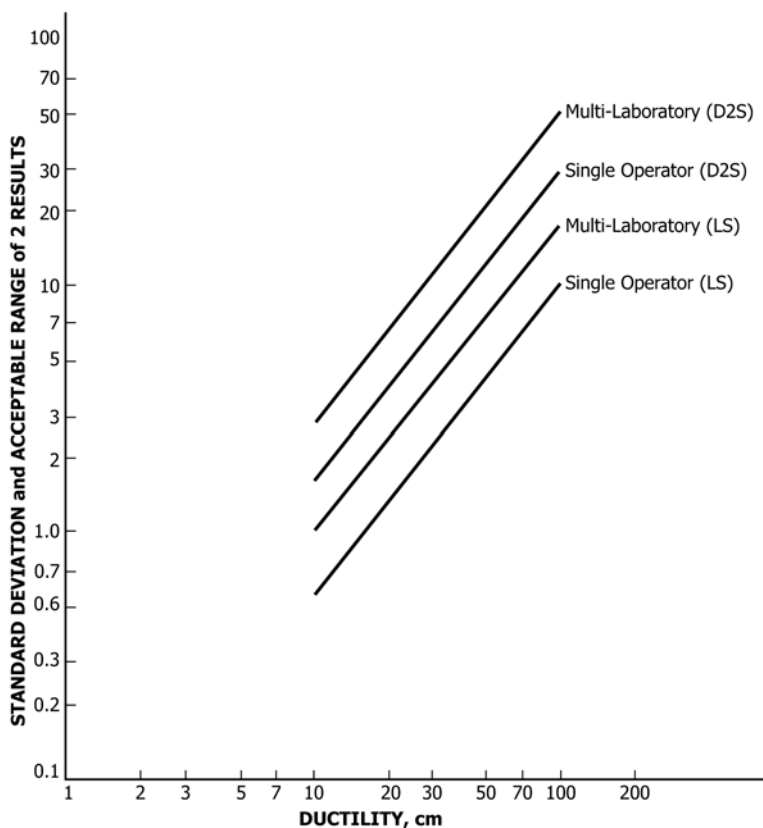

FIG. 2 Precision Data

ASTM International takes no position respecting the validity of any patent rights asserted in connection with any item mentioned in this standard. Users of this standard are expressly advised that determination of the validity of any such patent rights, and the risk of infringement of such rights, are entirely their own responsibility.

This standard is subject to revision at any time by the responsible technical committee and must be reviewed every five years and if not revised, either reapproved or withdrawn. Your comments are invited either for revision of this standard or for additional standards and should be addressed to ASTM International Headquarters. Your comments will receive careful consideration at a meeting of the responsible technical committee, which you may attend. If you feel that your comments have not received a fair hearing you should make your views known to the ASTM Committee on Standards, at the address shown below.

This standard is copyrighted by ASTM International, 100 Barr Harbor Drive, PO Box C700, West Conshohocken, PA 19428-2959, United States. Individual reprints (single or multiple copies) of this standard may be obtained by contacting ASTM at the above address or at 610-832-9585 (phone), 610-832-9555 (fax), or service@astm.org (e-mail); or through the ASTM website (www.astm.org). Permission rights to photocopy the standard may also be secured from the Copyright Clearance Center, 222 Rosewood Drive, Danvers, MA 01923, Tel: (978) 646-2600; <http://www.copyright.com/>