



Designation: D1092 – 12 (Reapproved 2017)

Standard Test Method for Measuring Apparent Viscosity of Lubricating Greases¹

This standard is issued under the fixed designation D1092; the number immediately following the designation indicates the year of original adoption or, in the case of revision, the year of last revision. A number in parentheses indicates the year of last reapproval. A superscript epsilon (ϵ) indicates an editorial change since the last revision or reapproval.

This standard has been approved for use by agencies of the U.S. Department of Defense.

1. Scope

1.1 This test method covers measurement, in poises, of the apparent viscosity of lubricating greases in the temperature range from $-54\text{ }^{\circ}\text{C}$ to $38\text{ }^{\circ}\text{C}$ ($-65\text{ }^{\circ}\text{F}$ to $100\text{ }^{\circ}\text{F}$). Measurements are limited to the range from 25 P to 100 000 P at 0.1 s^{-1} and 1 P to 100 P at 15 000 s^{-1} .

NOTE 1—At very low temperatures the shear rate range may be reduced because of the great force required to force grease through the smaller capillaries. Precision has not been established below 10 s^{-1} .

1.2 This standard uses inch-pound units as well as SI (acceptable metric) units. The values stated first are to be regarded as standard. The values given in parentheses are for information only. The capillary dimensions in SI units in Fig. A1.1 and Fig. A1.2 are standard.

1.3 **WARNING**—Mercury has been designated by many regulatory agencies as a hazardous material that can cause central nervous system, kidney and liver damage. Mercury, or its vapor, may be hazardous to health and corrosive to materials. Caution should be taken when handling mercury and mercury containing products. See the applicable product Material Safety Data Sheet (MSDS) for details and EPA's website—<http://www.epa.gov/mercury/faq.htm>—for additional information. Users should be aware that selling mercury and/or mercury containing products into your state or country may be prohibited by law.

1.3.1 In addition, temperature measuring devices such as liquid-in-glass thermometers, thermocouples, thermistors, or platinum resistance thermometers that provide equivalent or better accuracy and precision, that cover the temperature range for ASTM thermometer 49C, may be used.

1.4 *This standard does not purport to address all of the safety concerns, if any, associated with its use. It is the responsibility of the user of this standard to establish appropriate safety, health and environmental practices and determine the applicability of regulatory limitations prior to use.*

¹ This test method is under the jurisdiction of ASTM Committee D02 on Petroleum Products, Liquid Fuels, and Lubricants and is the direct responsibility of Subcommittee D02.G0.02 on Consistency and Related Rheological Tests.

Current edition approved Aug. 1, 2017. Published August 2017. Originally approved in 1950. Last previous edition approved in 2012 as D1092 – 12. DOI: 10.1520/D1092-12R17.

1.5 *This international standard was developed in accordance with internationally recognized principles on standardization established in the Decision on Principles for the Development of International Standards, Guides and Recommendations issued by the World Trade Organization Technical Barriers to Trade (TBT) Committee.*

2. Referenced Documents

2.1 *ASTM Standards:*²

D88 Test Method for Saybolt Viscosity

D217 Test Methods for Cone Penetration of Lubricating Grease

D3244 Practice for Utilization of Test Data to Determine Conformance with Specifications

3. Terminology

3.1 *Definitions:*

3.1.1 *apparent viscosity, n*—of a lubricating grease is the ratio of shear stress to shear rate calculated from Poiseuille's equation, and is measured in poises (see 10.1).

3.1.2 *capillary, n*—For the purpose of this test method, a capillary is any right cylindrical tube having a length to diameter ratio of 40 to 1.

3.1.3 *shear rate, n*—the rate at which a series of adjacent layers of grease move with respect to each other; proportional to the linear velocity of flow divided by the capillary radius, and is thus expressed as reciprocal seconds.

4. Summary of Test Method

4.1 The sample is forced through a capillary by means of a floating piston actuated by the hydraulic system. From the predetermined flow rate and the force developed in the system, the apparent viscosity is calculated by means of Poiseuille's equation. A series of eight capillaries and two pump speeds are used to determine the apparent viscosity at sixteen shear rates. The results are expressed as a log-log plot of apparent viscosity versus shear rate.

² For referenced ASTM standards, visit the ASTM website, www.astm.org, or contact ASTM Customer Service at service@astm.org. For *Annual Book of ASTM Standards* volume information, refer to the standard's Document Summary page on the ASTM website.

5. Significance and Use

5.1 Apparent viscosity versus shear rate information can be useful in predicting pressure drops in grease distribution systems under steady-state flow conditions at constant temperature.

6. Apparatus

6.1 The assembled pressure viscometer consists of four major divisions, the power system, the hydraulic system, the grease system (described in the annex and shown in Fig. 1), and a bath of optional design. Fig. 2 is a photograph of the first three divisions as commonly used at room temperature. This form of the apparatus can be used with a cylindrical insulated tank 178 mm (7 in.) in diameter and 508 mm (20 in.) deep. The bath medium may be kerosene or alcohol cooled manually with dry ice. Alternatively the grease system, the grease and hydraulic system, or all three major divisions can be built into any liquid or air bath that will cover the temperature range and maintain the grease at test temperature $\pm 0.25^\circ\text{C}$ ($\pm 0.5^\circ\text{F}$).

7. Sampling

7.1 A single filling of the grease cylinder requires about 0.223 kg (1/2 lb) of grease which is the minimum size sample.

NOTE 2—It is possible for an experienced operator to complete the 16 single determinations with a single filling. However, some samples reach the equilibrium pressure slowly, making it advisable to have a sample of several pounds available.

7.2 Generally no special preparation of the sample is necessary.

NOTE 3—The apparatus works the samples to some extent as they pass through the capillary. Somewhat better precision is obtained if they are previously worked as described in Test Methods D217. Working of some greases may cause aeration.

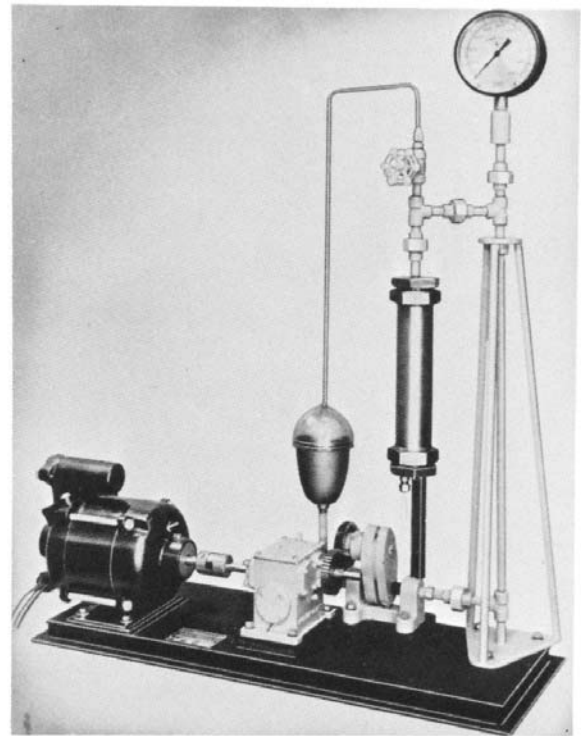

FIG. 2 Photograph of Apparatus

NOTE 4—It is desirable to filter some greases through a 60-mesh screen to prevent plugging the No. 8 capillary. Follow prudent laboratory practice to keep equipment cleaned and flushed before use.

8. Calibration and Standardization

8.1 To calibrate the hydraulic system, remove the grease cylinder and replace it with a needle valve. Select a hydraulic

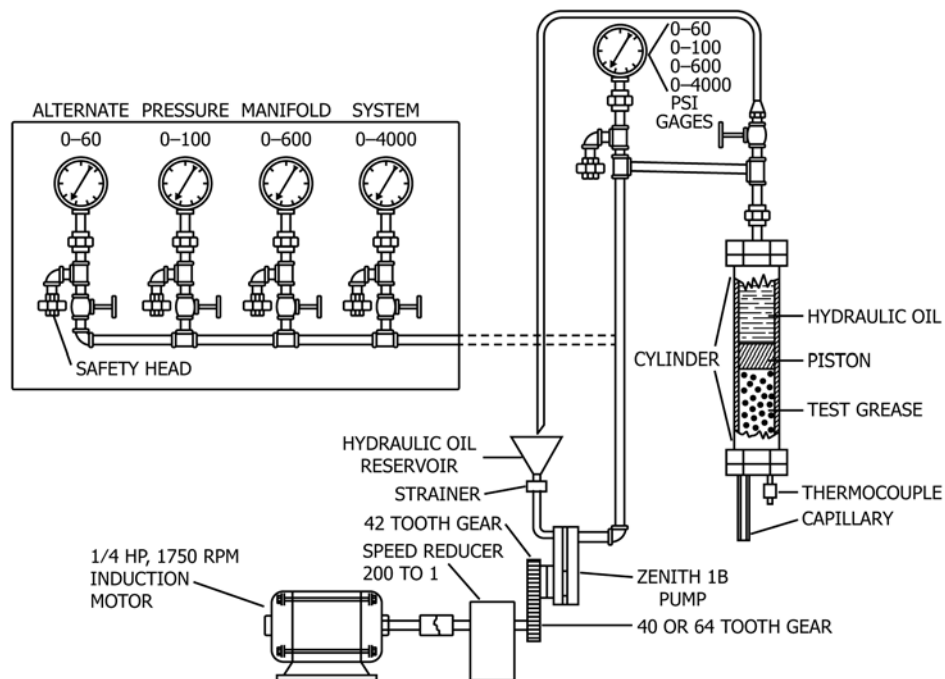

FIG. 1 Schematic Drawing of Apparatus

oil of about 2000 cSt (2000 mm²/s) viscosity at the test temperature. Fill the system with hydraulic oil and circulate the oil until it is free of air bubbles. At atmospheric pressure, quickly place a 60 mL Saybolt receiving flask (Test Method D88), under the outlet and start a timer. Determine the delivery time for 60 mL and calculate the flow rate in cubic centimetres per second assuming 1 mL equal to 1 cm³. Repeat this observation at 500 psi, 1000 psi, 1500 psi (3.45 MPa, 6.89 MPa, 10.4 MPa) and at sufficient pressures above 1500 psi to develop a calibration curve of the type as shown in Fig. 3. The developed curve of the type is used to correct flow rates when grease is dispensed. Repeat the calibration at intervals to determine if wear is changing the pump flow.

8.2 An alternative procedure for the calibration of the hydraulic system is the measurement of the rate of flow of the test grease. To cover the desired range of shear rates, flow rates over an approximate range of pressure are determined. Any suitable means of measuring the rate of grease flow may be used.

9. Procedure

9.1 Charge the sample so as to reduce inclusion of air to a minimum. Soft greases may be poured into the cylinder or drawn up by vacuum; heavy samples must be hand packed. When filling the cylinder by vacuum, remove the capillary end cap and place the piston flush with the open end and then insert into the sample. Apply vacuum to the opposite end of the cylinder until the cylinder is fully charged with grease. This must be facilitated by tapping with a wooden block. Replace the capillary end cap and fill the upper end of the cylinder above the piston with hydraulic oil.

9.2 Fill the entire hydraulic system with hydraulic oil. Disconnect, invert and fill the gage and gage connections with oil. With the entire hydraulic system connected and completely filled with oil, adjust the temperature of the sample to the test temperature ±0.25 °C (±0.5 °F) as determined by a thermocouple inserted in the capillary end cap. Operate the pump until oil flows from the gage connection on the viscometer before reconnecting the gage. With the entire viscometer assembled, circulate hydraulic oil with the return valve open until all trace of air is eliminated.

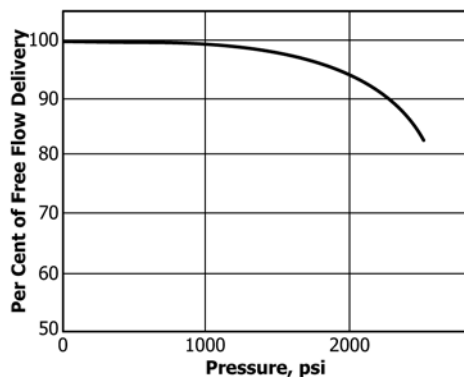

FIG. 3 Typical Pump Calibration Curve

9.2.1 The time to attain test temperature varies with the bath. At -54 °C (-65 °F) the grease in an unstirred liquid bath should be ready to test in 2 h. Air baths can take as long as 8 h. An ASTM Thermometer 74F in the bath serves as a convenient secondary means of measuring the temperature at -54 °C (-65 °F). In an air bath the thermometer must be within 25.4 mm of the capillary.

NOTE 5—The use of an equivalent non-mercury filled replacement thermometer, such as a thermistors, platinum resistance thermometer, other liquid in glass thermometer, or thermocouple is under study in Subcommittee E20.09.

9.3 With No. 1 capillary in place and the 40-tooth gear connected, operate the pump with the return valve closed until equilibrium pressure is obtained. Record the pressure. Change to the 64-tooth gear and again establish equilibrium. Record and relieve the pressure. Replace the No. 1 capillary with subsequent ones and repeat these operations until tests have been run with all capillaries at both flow rates. With some soft or hard greases, it cannot be practical to use all of the capillaries.

NOTE 6—It may be necessary to refill the cylinder with fresh grease when all 16 determinations are to be made.

NOTE 7—The use of an equivalent non-mercury filled replacement thermometer is under study in Subcommittee E20.09.

10. Calculation

10.1 Calculate apparent viscosity of the grease as follows:

$$\eta(\text{apparent viscosity}) = F/S \quad (1)$$

where F is the shear stress, and S is the shear rate. Therefore:

$$\eta = F/S = \frac{p\pi R^2/2\pi RL}{(4v/t)/\pi R^3} = p\pi R^4/(8Lv/t) = P68944\pi R^4/(8Lv/t) \quad (2)$$

where:

- p = pressure dynes/cm²,
- L = capillary length, cm,
- P = observed gage pressure, psi (multiply by 68944 to convert to dynes per square centimetre),
- R = radius of capillary used, cm, and
- v/t = flow rate, cm³/s.

10.2 Calculations may be reduced to a minimum by preparing a table of 16 constants, one for each capillary and shear rate (Table 1). For example, viscosity with No. 1 capillary and the 40-tooth gear is given as follows:

$$\eta = P(\text{observed})68944\pi R^4/(8Lv/t) \text{ or } PK_{(1-40)}$$

where:

$$K_{(1-40)} = 68944 \pi R^4/(8Lv/t) \quad (4)$$

10.3 Also calculate the shear rates as follows:

$$S = (4v/t)/\pi R^3 \quad (5)$$

Correct the flow rate to correspond to the observed pressure by reference to Fig. 3. Calculate 16 shear rates for the eight capillaries and two flow rates. This calculation need not be repeated for each run since it will remain constant until recalibration of the pump indicates a revision.

10.4 Plot a curve of apparent viscosity versus shear rate on log-log paper, as shown in Fig. 4.

TABLE 1 Suggested Data Sheet for Recording Test Results (With Illustrative Test Values)

Sample	No. 2 Grease			Temperature	25°C		
Date	Nov. 1, 1948			Operator	R.S.		
	1	2	3	4 ^A	5 ^B	6 ^A	7 ^C
Capillary	Gear	Observed Pressure, P, psi	$K = 68944 \pi R^{-4} / (8Lv/f)$	Apparent Viscosity, n poises, = $P \times K$	Shear Rate, S, s ⁻¹ = $(4v/f) / \pi R^3$	Shear Stress, dynes per sq cm = $n \times S$	
1	40	25.5	28.10	716	15	10 740	
2	40	38.3	6.83	267	61	16 300	
3	40	48.8	3.61	176	120	21 100	
4	40	63.5	1.90	120	230	27 800	
5	40	96.5	0.89	86	480	41 300	
6	40	125	0.58	72.6	755	54 800	
7	40	286	0.139	39.8	3 140	125 000	
8	40	546	0.0464	25.3	9 320	235 500	
1	64	29.5	17.60	520	24	12 470	
2	64	45.8	4.27	195	98	19 100	
3	64	60	2.26	135.5	195	26 400	
4	64	82.3	1.19	97.9	370	36 250	
5	64	130	0.556	72.4	770	55 800	
6	64	165	0.363	59.9	1 220	73 200	
7	64	384	0.087	33.4	5 020	167 500	
8	64	720	0.029	20.9	14 900	311 000	

^A Values in this column are predetermined.

^B Column 3 times Column 4.

^C Column 5 times Column 6.

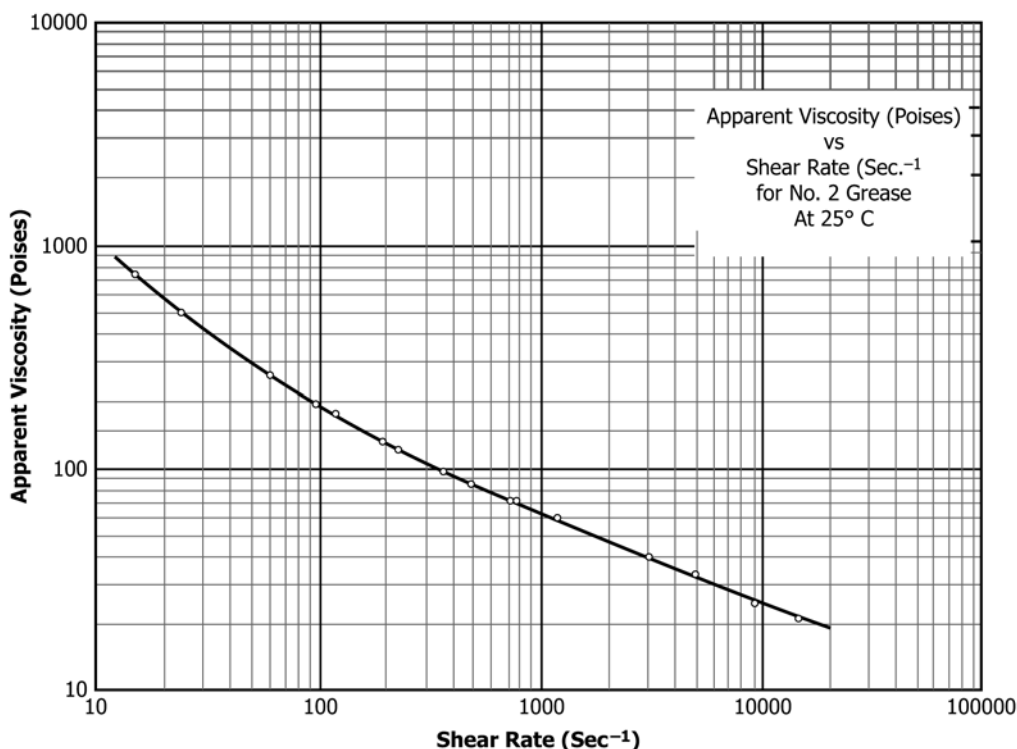

FIG. 4 Typical Chart for Apparent Viscosity versus Shear Rate

NOTE 8—Shear stresses also can be calculated by multiplying apparent viscosities by their corresponding shear rates. For solving various problems involving the steady flow of greases, shear stress-shear rate relationships may be plotted on appropriate charts. Instructions on the use of these charts are given in the article by Rein and McGahey.³

³ Rein and McGahey, "Predicting Grease Flow in Large Pipes," *NLGI Spokesman*, April 1965.

11. Precision and Bias

11.1 Due to the nature of the results, the precision of this test method was not obtained according to RR:D02-1007, "Manual on Determining Precision Data for ASTM Methods on Petroleum Products and Lubricants." The precision of this test method as determined by statistical examination of inter-laboratory results is as follows:

11.2 The data in 11.2.1 and 11.2.2 should be used for judging the acceptability of results (95 % confidence) according to the concept of precision as given in Practice D3244.

11.2.1 *Repeatability*—The difference between two test results, obtained by the same operator with the same apparatus under constant operating conditions on identical test material, would in the long run, in the normal and correct operation of the test method, exceed the values given in Table 2 only in one case in twenty.

11.2.2 *Reproducibility*—The difference between two single and independent results obtained by different operators work-

ing in different laboratories on identical test material would, in the long run, in the normal and correct operation of the test method, exceed the values given in Table 2 only in one case in twenty.

11.2.3 Reproducibility of the curve drawing operation varies from 5 to 8 % for the above samples. These data are based upon curve values of apparent viscosity at the six shear rates. A separate curve was drawn for each run.

11.3 *Bias*—Since there is no accepted reference material suitable for determining the bias for the procedure in Test Method D1092, bias has not yet been determined.

11.4 There is no research report on Test Method D1092 because this test method was developed before research report guidelines were instituted, and are no longer available.

TABLE 2 Precision

Sample	Temp, °F	Repeat-	Repro-
		ability	ducibility
		% of mean	
Smooth, NLGI 2, Diester Oil	-65	7	12
Smooth, NLGI 2, SAE 20 Oil	77	6	19
Fibrous, NLGI 1, SAE 20 Oil	77	6	23
Viscous, NLGI 1, SAE 90 Oil	77	7	30

12. Keywords

12.1 apparent viscosity; capillary; lubricating grease; shear rate; viscosity

ANNEX

(Mandatory Information)

A1. APPARATUS FOR GREASE SYSTEM

A1.1 *Apparatus* —Assembled pressure viscometer apparatus consists of four major parts: the power system, the hydraulic system, the grease system as shown in Fig. 1 and Fig. 2 and constructed as described in A1.2 – A1.6, and a bath of optional design.

A1.2 *Power System*, consisting of a 1/3 hp, 1750 r/min induction motor coupled to a 200 to 1 speed reducer. Interchangeable 40 and 64-tooth gears are used to drive the hydraulic pump.

A1.3 *Hydraulic System*, consisting of a gear pump fitted with saddle mount and 42-tooth drive gear,^{4,5} a hydraulic oil reservoir having a capacity at least equal to that of the grease cylinder and fitted with a 50-mesh screen shall be provided. The pump and grease cylinder shall be connected with high pressure valves and fittings as shown in Fig. 1. Means shall be provided for connecting interchangeable test gages.

A1.4 *Gauges*—Since the gages are used only in the middle range, several are desirable to cover a wide variety of greases. Four gages having ranges from 0 psi to 60 psi (0.41 MPa), 0 psi to 100 psi (0.689 MPa), 0 psi to 600 psi (4.14 MPa), and 0 psi to 4000 psi (27.58 MPa) have been found suitable. Alternatively, the gages may be manifolded, provided proper means of eliminating air from the system is employed (Fig. 1).

A1.5 *Grease Cylinder Assembly*, consisting of cylinder, floating piston, and caps constructed to conform to the tolerances shown in Fig. A1.1 with the piston moving the entire length of the cylinder without appreciable friction. The cylinder shall be constructed to withstand a working pressure of 4000 psi (27.5 MPa). The exterior features and method of fastening may be modified.

A1.6 *Capillaries* —Capillaries, eight of stainless steel and conforming to dimensions shown in Fig. A1.2, shall comprise a set. Critical dimensions are the interior radius and length. It is essential that the radius of each be approximately that shown in Fig. A1.2, and that the length be 40 times the actual diameter. Exterior features of the mounting can be modified, provided proper protection and connection to the grease cylinder cap are provided.

A1.6.1 Capillaries can be calibrated by any suitable method (see Appendix X1). It should be recognized, however, that it may not be possible to recalibrate a correctly prepared capillary to the same precision used in its preparation, that is its length

⁴ The sole source of supply of the Nichols/Zenith pump BPB 4776-58L cc/rev with QF planetary drive known to the committee at this time is Nichols/Zenith Co., 48 Woerd Avenue, Waltham, MA 02154. If you are aware of alternative suppliers, please provide this information to ASTM International Headquarters. Your comments will receive careful consideration at a meeting of the responsible technical committee,¹ which you may attend.

⁵ The sole source of supply of the steady flow chart paper known to the committee at this time is NLGI, 4635 Wyandotte St., Kansas City, MO 64112-1596. If you are aware of alternative suppliers, please provide this information to ASTM International Headquarters. Your comments will receive careful consideration at a meeting of the responsible technical committee,¹ which you may attend.

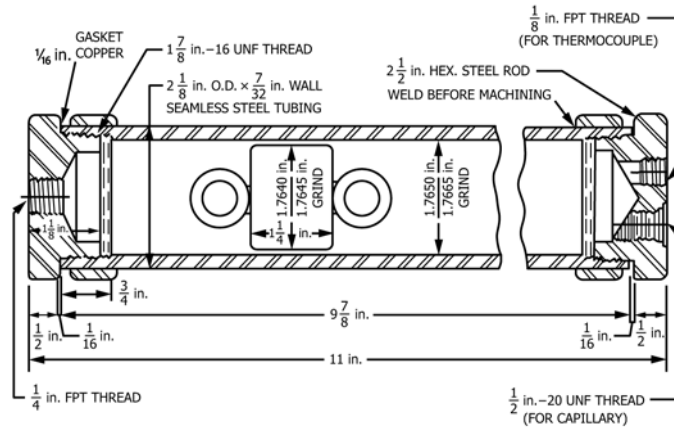

Metric Equivalents

Inches	Millimetres
1/16	1.59
7/32	5.56
1/2	12.70
3/4	19.05
1 1/8	28.58
1 1/4	31.75
1.7640	44.806
1.7645	44.818
1.7650	44.831
1.7665	44.869
1 7/8	47.63
2 1/8	53.98
2 1/2	63.50
9 7/8	250.83
11	279.40

NOTE 1—Adhere to standard manufacturing tolerance in the construction of this grease cylinder.

FIG. A1.1 Grease Cylinder Assembly

be 40 times its diameter ± 0.002 cm, due to inherent imprecision in the original calibration method. It is suggested that the original measurements and calculations used to construct the capillary be retained.

A1.6.2 The bores of new capillaries should be examined visually. Those capillaries with bores obviously rough or out of round are to be rejected. Capillaries which are damaged in use also are to be rejected.

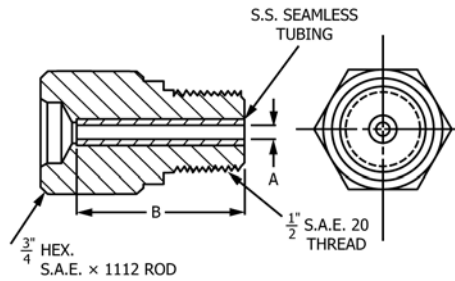

$$40 A \text{ (ACTUAL DIAMETER)} = B \text{ (LENGTH)} \pm 0.002 \text{ CM}$$

Capillary Number	A (Diameter) in Centimetres (Approximate)
1	0.380
2	0.240
3	0.185
4	0.150
5	0.120
6	0.100
7	0.065
8	0.045

Metric Equivalents	
Inches	Millimetres
3/4	19.05
1/2	12.07

NOTE 1—Adhere to standard manufacturing tolerance in construction of this capillary.

FIG. A1.2 Capillary Construction

APPENDIXES

(Nonmandatory Information)

X1. CALIBRATION OF CAPILLARIES

X1.1 There are several methods to calibrate the capillaries required for this test method. Capillaries are usually obtained from a supplier already calibrated. If the user wishes to produce capillaries himself, the methods outlined below will serve. Users should refer to A1.6 for information on recalibration of an existing capillary.

X1.2 A calibration method that can be used to check the small capillary radius consists of using an oil of known viscosity in place of the grease sample and following the

procedure described in Section 9. Calculate the radius, R , as follows:

$$R = [(8L\eta v/t)/\pi P 68944]^{1/4} = [(L\eta v/t)/27076P]^{1/4} \quad (X1.1)$$

where:

L = capillary length, cm.

η = viscosity of oil used at test temperature, P,

v/t = flow rate, mL/s, determined in pump calibration, and

P = gage pressure, psi.

X2. ALTERNATIVE PROCEDURES FOR MEASURING APPARENT VISCOSITY AT LOW SHEAR RATES

CONSTANT-PRESSURE TECHNIQUE

X2.1 Apparatus

X2.1.1 *Grease Cylinder Assembly*, as shown in Fig. A1.1 and the No. 1 capillary. The grease cylinder and piston assembly is described in A1.5.

X2.1.2 *Nitrogen Cylinder*, or a suitable source of dry compressed air, regulator, and vent valve.

X2.1.3 *Calibrated Gages*, to measure pressure. Usually 0 psi to 15 psi (0.10 MPa) and 0 psi to 30 psi (0.21 MPa) Bourdon gages are sufficient. In lieu of the gages, a suitable manometer can be used.

X2.1.4 *Constant-Temperature Bath*, or cold room for low-temperature determinations. Constant temperature room or bath for tests at 25 °C (77 °F).

X2.1.5 *Buret*, 10-mL with side arm, suitable connections, and a liquid (denatured alcohol) reservoir. It is generally unnecessary to compensate for a difference in temperature of the alcohol in the reservoir and in the buret. For convenience, the buret can be outside the low-temperature bath.

X2.1.6 *Flexible Tubing*, from the pressure gage to the cylinder.

X2.1.7 *Stop Watch*, or other suitable timer.

X2.2 Procedure

X2.2.1 Carefully fill the grease cylinder and capillary to minimize entrapped air. Fill the system beyond the capillary with alcohol.

X2.2.2 Check for gas leaks by applying pressure.

X2.2.3 Allow the system to stabilize for 2 h at the desired temperature before making a determination.

X2.2.4 Bring the system up to the desired pressure by adjusting the pressure regulator and vent. (Some trial and error may be necessary to determine the pressure ranges to give the desired flow rates for different greases and temperatures.) The

grease will be forced through the capillary displacing an equal volume of alcohol which then goes into the buret. This can be measured in cubic centimeters per second for determining the shear rate. Make three determinations at a given pressure and temperature, provided the flow rate appears to be constant. If varying flow rates are noted, more determinations should be made until the flow rate appears to be constant. Readings should be taken in order of decreasing pressures. Average the results of the flow rate in cubic centimetres per second.

X2.3 Precision and Bias

X2.3.1 Precision and bias have not been determined for this test procedure.

CONSTANT-FLOW TECHNIQUE

X2.4 Apparatus

X2.4.1 The apparatus is essentially the same as described in Section 6 of the test method. A larger (No. 0) capillary (Note X2.1) used in conjunction with the regular equipment permits measurements at a shear rate of about 1 s⁻¹. Because pressures at low shear rates are low, care must be exercised to have the apparatus calibrated and in good working condition to keep errors at a minimum.

NOTE X2.1—Recommended dimensions for the No. 0 capillary are:

Diameter	9.525 mm ± 0.025 mm	(0.375 in. ± 0.001 in.)
Length	381.000 mm ± 0.025 mm	(15.000 in. ± 0.001 in.)

X2.5 Procedure

X2.5.1 The procedure, using a larger capillary, is the same as described in 9.1 and 9.2.

X2.5.2 For shear rates significantly below 1 s⁻¹, a modified variable speed pumping system is recommended. However, data obtained in cooperative testing indicate extrapolation from 1 s⁻¹ down to 0.1 s⁻¹ may be feasible.

X2.6 Precision and Bias

X2.6.1 Precision and bias have not been determined for this test method.

ASTM International takes no position respecting the validity of any patent rights asserted in connection with any item mentioned in this standard. Users of this standard are expressly advised that determination of the validity of any such patent rights, and the risk of infringement of such rights, are entirely their own responsibility.

This standard is subject to revision at any time by the responsible technical committee and must be reviewed every five years and if not revised, either reapproved or withdrawn. Your comments are invited either for revision of this standard or for additional standards and should be addressed to ASTM International Headquarters. Your comments will receive careful consideration at a meeting of the responsible technical committee, which you may attend. If you feel that your comments have not received a fair hearing you should make your views known to the ASTM Committee on Standards, at the address shown below.

This standard is copyrighted by ASTM International, 100 Barr Harbor Drive, PO Box C700, West Conshohocken, PA 19428-2959, United States. Individual reprints (single or multiple copies) of this standard may be obtained by contacting ASTM at the above address or at 610-832-9585 (phone), 610-832-9555 (fax), or service@astm.org (e-mail); or through the ASTM website (www.astm.org). Permission rights to photocopy the standard may also be secured from the Copyright Clearance Center, 222 Rosewood Drive, Danvers, MA 01923, Tel: (978) 646-2600; http://www.copyright.com/