



Standard Specification for Rubber Insulating Line Hose¹

This standard is issued under the fixed designation D1050; the number immediately following the designation indicates the year of original adoption or, in the case of revision, the year of last revision. A number in parentheses indicates the year of last reapproval. A superscript epsilon (ϵ) indicates an editorial change since the last revision or reapproval.

This standard has been approved for use by agencies of the U.S. Department of Defense.

1. Scope

1.1 This specification covers acceptance testing of rubber insulating line hose for use as a portable protective device for protection of workers from accidental contact with live electrical conductors.

1.2 Two types of line hose are provided and are designated as Type I, non-resistant to ozone, and Type II and Type III, resistant to ozone.

1.3 Five classes of line hose, differing in electrical characteristics, are provided and are designated as Class 0, Class 1, Class 2, Class 3, and Class 4.

1.4 Four styles of line hose, differing in design characteristics, are provided and are designated as Style A, Style B, Style C, and Style D.

1.5 The following precautionary caveat pertains only to the test method portion, Sections 16, 17, 18, 19, of this specification: *This standard does not purport to address all of the safety concerns, if any, associated with its use. It is the responsibility of the user of this standard to establish appropriate safety and health practices and determine the applicability of regulatory limitations prior to use.* For specific precautionary statements, see 18.1.1.

2. Referenced Documents

2.1 *ASTM Standards*:²

D297 Test Methods for Rubber Products—Chemical Analysis

D412 Test Methods for Vulcanized Rubber and Thermoplastic Elastomers—Tension

D570 Test Method for Water Absorption of Plastics

¹ This specification is under the jurisdiction of ASTM Committee F18 on Electrical Protective Equipment for Workers and is the direct responsibility of Subcommittee F18.25 on Insulating Cover-Up Equipment. This standard replaces ANSI Standard J 6.1, which is no longer available.

Current edition approved Sept. 1, 2011. Published September 2011. Originally approved in 1949 as D1050 – 49 T. Last previous edition approved in 2005 as D1050 – 05 ϵ 1. DOI: 10.1520/D1050-05R11.

² For referenced ASTM standards, visit the ASTM website, www.astm.org, or contact ASTM Customer Service at service@astm.org. For *Annual Book of ASTM Standards* volume information, refer to the standard's Document Summary page on the ASTM website.

D573 Test Method for Rubber—Deterioration in an Air Oven

D624 Test Method for Tear Strength of Conventional Vulcanized Rubber and Thermoplastic Elastomers

D2865 Practice for Calibration of Standards and Equipment for Electrical Insulating Materials Testing

F819 Terminology Relating to Electrical Protective Equipment for Workers

2.2 *Federal Specification*:³

PPP-B-636 Box, Shipping, Filterboard

2.3 *ANSI Standards*:⁴

C 2 National Electrical Safety Code, Section 44

C 39.5 Safety Requirements for Electrical and Electronic Measuring and Controlling Instrumentation

C 84.1 Electric Power Systems and Equipment—Voltage Ratings

3. Terminology

3.1 *Definitions of Terms Specific to This Standard*:

3.1.1 *breakdown*—the electrical discharge or arc occurring between the electrodes and through the equipment being tested.

3.1.2 *flashover*—the electrical discharge or arc occurring between electrodes and over or around, but not through, the equipment being tested.

3.1.3 *electrical testing facility*—a location with qualified personnel, testing equipment, and procedures for the inspection and electrical testing of electrical insulating protective equipment.

3.1.4 *electrode clearance*—the shortest path from the energized electrode to the ground electrode.

3.1.5 *insulated*—separated from other conducting surfaces by a dielectric substance (including air space) offering a high resistance to the passage of current.

NOTE 1—When any object is said to be insulated, it is understood to be insulated in a suitable manner for the conditions to which it is subjected. Otherwise, it is, within the purpose of this definition, uninsulated.

³ Available from Standardization Documents, Order Desk, Bldg. 4, Section D, 700 Robbins Ave., Philadelphia, PA 19111-5094, ATTN: NPODS.

⁴ Available from American National Standards Institute, 11 West 42nd Street, 13th Floor, New York, NY 10036.

Insulating covering of conductors is one means of making the conductor insulated.

3.1.6 *isolated*—an object that is not readily accessible to persons unless special means of access are used.

3.1.7 *ozone*—a very active form of oxygen that may be produced by corona, arcing, or ultra-violet rays.

3.1.8 *ozone cutting and checking*—the cutting action produced by ozone on rubber under mechanical stress into a series of interlacing cracks.

3.1.9 *rubber*—a generic term that includes elastomers and elastomeric compounds, regardless of origin.

3.1.10 *voltage, maximum use*—the ac voltage (rms) rating of the protective equipment that designates the maximum nominal design voltage of the energized system that may be safely worked. The nominal design voltage is equal to the phase to phase voltage on multiphase circuits.

3.1.11 If there is not multiphase exposure in a system area and the voltage exposure is limited to phase (polarity on dc systems) to ground potential, the phase (polarity on dc systems) to ground potential shall be considered to be the nominal design voltage. If electrical equipment and devices are insulated, or isolated, or both, such that the multiphase exposure on a grounded wye circuit is removed, then the nominal design voltage may be considered as the phase-to-ground voltage on that circuit.

NOTE 2—The work practices and methods associated with removing multiphase exposures at any given work site are not addressed in this specification. Users should refer to ANSI C2, National Safety Code, Section 44, for proper work practices.

3.1.12 *voltage, nominal design*—a nominal value consistent with the latest revision on ANSI C 84.1, assigned to the circuit or system for the purpose of conveniently designating its voltage class.

3.2 For definitions of other terms, refer to Terminology F819.

4. Significance and Use

4.1 This specification covers the minimum electrical, chemical, and physical properties guaranteed by the manufacturer and the detailed procedures by which such properties are

TABLE 1 Proof-Test/Use Voltage Relationship

| Class of Insulating Line Hose | Nominal Maximum Use Voltage ^A Phase-Phase, ac rms, V | AC Proof-Test Voltage, rms V | DC Proof-Test Voltage, avg, V, |
|-------------------------------|---|------------------------------|--------------------------------|
| 0 | 1 000 | 5 000 | 20 000 |
| 1 | 7 500 | 10 000 | 40 000 |
| 2 | 17 000 | 20 000 | 50 000 |
| 3 | 26 500 | 30 000 | 60 000 |
| 4 | 36 000 | 40 000 | 70 000 |

^A Except for Class 0 equipment, the maximum use voltage is based on the following formula:

$$\text{Maximum use voltage} = 0.095 \text{ ac proof-test voltage} - 2000$$

The formula takes into account the reduction in the volts per mil capability of the material with increasing thickness.

to be determined. The purchaser may at his option perform or have performed any of these tests in order to verify the guarantee. Claims for failure to meet the specification are subject to verification by the manufacturer.

4.2 Line hose is used for personal protection; therefore, when authorizing its use, a margin of safety should be provided between the maximum voltage at which it is used and the proof-test voltage at which it is tested. The relationship between proof-test voltage and the nominal maximum voltage at which line hose shall be used is shown in Table 1.

4.3 It is common practice for the user of this type of protective equipment to prepare complete instructions and regulations to govern in detail the correct and safe use of such equipment.

5. Classification

5.1 Line hose covered under this specification shall be designated as Type I, Type II, or Type III; Class 0, Class 1, Class 2, Class 3, or Class 4; Style A, Style B, Style C, or Style D.

5.1.1 *Type I*, non-resistant to ozone, made from a high-grade *cis*-1,4-polyisoprene rubber compound of natural or synthetic origin, properly vulcanized.

5.1.2 *Type II*, ozone resistant, made of any elastomer or combination of elastomeric compounds.

TABLE 2 AC Voltage Requirements

| Hose Size, ID, in. | Test Mandrel Size, in. ^A | Types I, II, and III Style A and B | | | Types II and III Style C and D | | |
|--------------------|-------------------------------------|------------------------------------|---------------------------|--|--------------------------------|---------------------------|--|
| | | Class | Proof-Test Voltage, rms V | Minimum Flashover Test Voltage, ^B rms V | Class | Proof-test Voltage, rms V | Minimum Flashover Test Voltage, ^B rms V |
| 1/4 | 3/16 | 0 | 5 000 | 6 000 | 0 | 5 000 | 7 000 |
| 5/8 | 9/16 | 1 | 10 000 | 12 000 | 1 | 10 000 | 20 000 |
| 1 | 1 5/16 | 2 | 20 000 | 22 000 | 2 | 20 000 | 30 000 |
| 1 1/4 | 1 3/8 | 2 | 20 000 | 25 000 | 2 | 20 000 | 35 000 |
| 1 1/2 | 1 1/4 | 3 | 30 000 | 30 000 | 4 | 40 000 | 50 000 |
| 2 | 1 3/4 | 3 | 30 000 | 32 000 | 4 | 40 000 | 50 000 |
| 2 1/2 | 2 1/4 | 3 | 30 000 | 35 000 | 4 | 40 000 | 60 000 |

^A Commercially available copper, brass, or iron tubing, conduit, or rod that approximates these nominal sizes is acceptable.

^B The flashover test values investigate design capability of each style of line hose.

5.1.3 *Type III*, ozone resistant, made of any combination of an elastomer and thermoplastic polymers, elastic in nature.

5.1.4 The class designation shall be based on the electrical properties as shown in [Table 1](#), [Table 2](#), or [Table 3](#).

5.1.5 *Style A* line hose shall be designed in the straight style with a constant cross section throughout the length of the line hose ([Fig. 1](#)).

5.1.6 *Style B* line hose shall be designed in the connector-end style, which is similar to the straight style except that it shall have a molded connector permanently affixed to one end of the line hose ([Fig. 1](#)).

5.1.7 *Style C* line hose shall be designed in the extended-lip style with major outward extending lips ([Fig. 1](#)).

5.1.8 *Style D* line hose shall be designed in the extended lip style with major outward extending lips. It shall have a molded connector permanently affixed to one end of the line hose ([Fig. 1](#)).

NOTE 3—Rubber insulating line hose should remain suitably flexible for application and removal through normal working temperatures of -29 to 54.5°C (-20 to 130°F).

NOTE 4—Separate molded connectors are available to connect two lengths of Style A or Style C line hose.

6. Ordering Information

6.1 Orders for line hose under this specification should include the following information:

- 6.1.1 Type,
- 6.1.2 Class,
- 6.1.3 Style,
- 6.1.4 Size, and
- 6.1.5 Length.

6.2 The listing of types, classes, styles, sizes, and lengths is not intended to mean that all shall necessarily be available from manufacturers; it signifies only that, if made, they shall conform to the details of this specification. In addition, lengths other than standard lengths may be obtained to meet field conditions.

6.3 Factory-produced openings located on the top, sides, or lips of the hose are permissible. These openings must be specified on the purchase order and shall not be larger than 25 mm (1 in.) in diameter and the center of the opening shall not

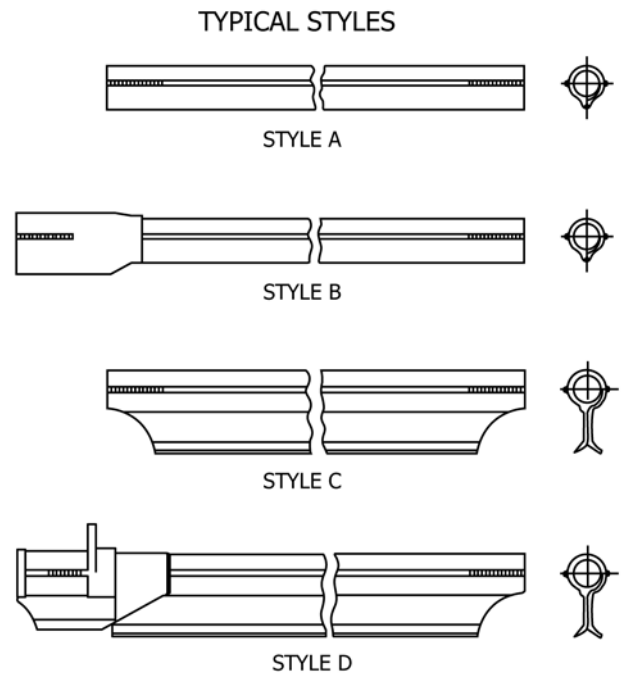

FIG. 1 Typical Styles

be more than 25 mm from the end of the hose or less than 25 mm from the edge of the lips.

7. Manufacture and Marking

7.1 The line hose shall be constructed in four styles: straight style, connector-end style, extended-lip style, and connector-end extended-lip style. The line hose shall be formed with an interlocking lip of sufficient length to prevent the device from being dislodged accidentally from the conductor it covers. The interlocking lip shall be closely adjacent to the inside surface contour of the outer wall. The adapter end of connector-end style line hose shall be not less than 140 mm (5½ in.) deep, and its inside diameter shall be such that it will snugly grip the end of the line hose of the same size which it joins.

7.2 Each line hose shall be marked clearly and permanently with the name of manufacturer or supplier, type, class, and

TABLE 3 DC Voltage Requirements

| Hose Size, ID, in. | Test Mandrel Size, in. ^A | Types I, II, and III Style A and B | | | Types II and III Style C and D | | |
|-----------------------|---|---------------------------------------|--|--|-----------------------------------|--|--|
| | | Class | Proof-Test Voltage, ^B avg V | Minimum Flashover Test Voltage, ^{C, D} avg V | Class | Proof-test Voltage, ^B avg V | Minimum Flashover Test Voltage, ^{C, D} avg V |
| ¼ | ⅜ | 0 | 10 000 | 12 000 | 0 | 10 000 | 15 000 |
| ⅝ | ⅜ | 1 | 30 000 | 30 000 | 1 | 30 000 | 55 000 |
| 1 | 1½ | 2 | 35 000 | 35 000 | 2 | 35 000 | 60 000 |
| 1¼ | 1¾ | 2 | 35 000 | 45 000 | 2 | 35 000 | 65 000 |
| 1½ | 1¾ | 3 | 50 000 | 50 000 | 4 | 60 000 | 75 000 |
| 2 | 1¾ | 3 | 50 000 | 60 000 | 4 | 60 000 | 75 000 |
| 2½ | 2¼ | 3 | 50 000 | 70 000 | 4 | 70 000 | 90 000 |

^A Commercially available copper, brass, or iron tubing, conduit, or rod that approximates these nominal sizes is acceptable.

^B dc proof-test values shown in Table 3 are limited due to the inability to seal lip openings.

^C The flashover test values investigate design capability of each style of line hose.

^D dc flashover values were determined using negative polarity.

ASTM D1050. Line hose may be marked by either molding the information directly into the hose or by use of a label; either method is equally acceptable. The method shall be at the discretion of the manufacturer. If a label is used, the color shall be that specified for each voltage class: Class 0—red, Class 1—white, Class 2—yellow, Class 3—green, and Class 4—orange.

8. Chemical and Physical Properties

8.1 Each line hose shall conform to the physical requirements in [Table 4](#) and, for Type I line hose, the determination of rubber polymer in accordance with [19.1.1](#).

9. Electrical Requirements

9.1 Each line hose shall withstand the 60-Hz ac proof-test voltage (rms value) specified in [Table 2](#) or the dc proof test voltage (average value) specified in [Table 3](#). The proof test shall be performed in accordance with Section [18](#) and shall be run continuously for 3 min.

9.2 Sample lengths of line hose, as specified in [14.3.2](#) and [14.3.3](#), shall pass the minimum flashover test values of [Table 2](#) or 3 when tested in accordance with [18.2](#).

9.3 Sample lengths of Type II and Type III line hose, as specified in [14.3.4](#), shall show no visible effects from ozone when tested in accordance with [18.3](#). Any visible signs of ozone deterioration, such as checking, cracking, breaks, pitting, etc., shall be considered as evidence of failure to meet the requirements of Type II and Type III line hose.

10. Dimensions and Permissible Variations

10.1 *Size*—The inside diameter shall indicate the size of the line hose. Standard sizes shall be: 6.3 mm (¼ in.), 25 mm (1 in.), 31.5 mm (1¼ in.), 40 mm (1½ in.), 50 mm (2 in.), and 63.0 mm (2½ in.). The permissible variation in size shall be ± 2.0 mm ($\pm 1/16$ in.).

10.2 *Length*—Length shall be measured from end to end. Standard lengths for Styles A and C line hose shall measure 915 mm (3 ft), 1372 mm (4.5 ft) or 1820 mm (6 ft), with a permissible variation of ± 12.7 mm (± 0.5 in.). Standard overall lengths for Style B and D line hose shall be the same overall lengths as specified for straight type. The permissible variation in length for the connector-end shall be ± 12.7 mm (± 0.5 in.). In addition, lengths other than standard lengths may be obtained to meet field conditions.

10.3 *Thickness*—The wall thickness shall not be less than 3.2 mm (0.12 in.) for Class 0, 5.1 mm (0.20 in.) for Class 1, 5.6

mm (0.22 in.) for Class 2, 6.4 mm (0.25 in.) for Class 3, and 6.4 mm (0.25 in.) for Class 4.

11. Workmanship, Finish, and Appearance

11.1 The line hose shall be free from harmful physical irregularities, which can be detected by thorough test or inspection.

11.1.1 *Non-Harmful Irregularities*—Surface irregularities may be present on all rubber goods due to imperfections on forms, molds, or extruding dies, and inherent difficulties in the manufacturing process. These irregularities may appear as indentations, protuberances, or imbedded foreign material that are acceptable provided that:

11.1.1.1 The indentation or protuberance tends to blend into a smooth slope upon stretching of the material,

11.1.1.2 Foreign material remains in place when the hose is bent and stretches equally with the material surrounding it.

12. Guarantee

12.1 The manufacturer or supplier shall replace without charge to the purchaser, unused line hose which at any time within a period of nine months, from date of receipt of shipment by the purchaser or his designee, fails to pass the tests in this specification. Acceptance tests made by the purchaser or his designee shall be performed within two months of receipt by the purchaser or his designee unless otherwise specified. Tests shall be performed as shown in Section [16](#).

NOTE 5—Proper storage means that the line hose are stored without distortion, and not stored directly above or in proximity to steam pipes, radiators, or other sources of artificial heat, or exposed to direct sunlight or other sources of ozone. It is desirable that the ambient storage temperature shall not exceed 35°C (95°F).

13. Sampling

13.1 Each line hose in a lot or shipment shall be subject to inspection and test to meet the requirements of Sections [7](#), [9.1](#), [11](#), and [15](#).

13.2 An original sample on 1 % of the lot or shipment or not less than two lengths of hose, whichever is greater, shall be selected at random for the test requirements of Section [9.2](#), [9.3](#), and [10](#). If a failure occurs in the first sample, a second sample of the same quantity shall be selected and tested.

13.3 An original sample of 0.1 % of the lot or shipment or not less than two lengths of line hose, whichever is greater, shall be selected at random from the lot or shipment for the test requirements of [8](#).

14. Rejection

14.1 Individual line hose shall be rejected if they fail to meet the manufacturing and marking requirements of Section [7](#), the electrical requirements of [9.1](#), the minimum thickness requirements of [10.3](#), or the workmanship requirements of Section [11](#).

14.2 Individual line hose may be rejected at the option of the purchaser if they fail to meet the requirements stipulated in [10.1](#), [10.2](#), or Section [15](#).

14.3 The entire lot or shipment of line hose shall be rejected under any of the following conditions:

TABLE 4 Physical Requirements

| | Type I Hose | Type II Hose | Type III Hose |
|--|-------------|--------------|---------------|
| Tensile strength, min, Die C, MPa(psi) | 11 (1600) | 4.8 (700) | 4.8 (700) |
| Elongation, min, % | 350 | 500 | 350 |
| Tension set (150 %), max, mm(in.) | 6.4 (0.25) | 6.4 (0.25) | 2.5 (0.10) |
| Tear resistance, min, kN/m (lbf/in.) | 17.5 (100) | 13.1 (75) | 13.1 (75) |
| Moisture absorption, max, % | 1.5 | 3.0 | 1.0 |

14.3.1 If 5 % or more, but not less than two hose, of the hose in a shipment fail to meet the requirements of 9.1.

14.3.2 If two pieces of line hose, from a sample of five pieces, fail to meet the minimum flashover values specified in Table 2 or 3 when tested to meet the requirements of 9.2.

14.3.3 If one piece of line hose, from the original sample of five pieces, and one piece of line hose, from a second sample of five additional pieces, fail to meet the minimum flashover values specified in Table 2 or 3 when tested to meet the requirements of 9.2.

14.3.4 If the sample lengths of Type II and Type III line hose, using the sampling methods and criteria specified in 14.3.2 and 14.3.3, fail to meet the ozone resistance requirements of 9.3.

14.4 The testing shall be terminated and the manufacturer or supplier notified if, during the course of testing, 5 % or more, but not less than two hose, of the hose in a lot or shipment fail to meet the requirements of 9.1, 9.2, or 9.3. The manufacturer may in such a case require the purchaser to submit proof that the test procedure and equipment conform to the appropriate paragraphs of Section 18. When such proof has been furnished, the manufacturer or supplier may request that his representative witness the testing of additional hose from the shipment.

14.5 If two of the five specimens tested fail any of the separate requirements outlined in Section 8, a second line hose shall be selected and, if one specimen from this line hose fails, the entire lot or shipment may be rejected at the option of the purchaser.

14.6 The entire lot or shipment of line hose may be rejected at the option of the purchaser if 25 % of the hose in the lot or shipment fail to meet the requirements of Sections 10 or 11.

14.7 All rejected material shall be returned as directed by the manufacturer, at his or the supplier's request, without being defaced by rubber stamp or other permanent marking. However, those hose punctured when tested in accordance with the requirements of 9.1 or 9.2 shall be stamped, punched, or cut prior to being returned to the supplier to indicate that they are unfit for electrical use.

15. Packaging

15.1 The line hose shall be packed for shipment in a straight or extended position and shall not be distorted mechanically while in transit.

NOTE 6—When specified in government contracts or purchase orders, material should be unit packaged in weather-resistant fiberboard boxes conforming to PPP-B-636, class weather resistant.

TEST METHODS

16. Sequence of Testing

16.1 *Testing Rubber Insulating Hose*—The following order of procedure is suggested:

16.1.1 Inspect the inside and outside surface in accordance with Section 11.

16.1.2 Measure dimensions in accordance with Section 17.

16.1.3 Electrical proof test in accordance with 18.1.

16.1.4 Electrical flashover test in accordance with 18.2.

16.1.5 Ozone resistance tests in accordance with 18.3.

16.1.6 Chemical and physical property tests in accordance with Section 19.

17. Thickness Measurements

17.1 *Apparatus*—Use a standard tube-measuring micrometer graduated to within 0.025 mm (0.001 in.), having a ratchet friction or spring attachment. Adjust the tension on the fraction attachment so that when the spindle has come to a stop, the specimen can be moved between the spindle and anvil without causing any appreciable stretching of the rubber.

17.2 *Procedure*—Make thickness measurements of each line hose at not less than five points, distributed around the periphery approximately 13.0 mm (½ in.) in from the straight end.

18. Electrical Tests⁵

18.1 *Electrical Proof Tests*—Both ac and dc proof-test methods are included in this section. It is intended that one method be selected for the electrical acceptance tests. The method selected shall be at the option of the purchaser, and the supplier should be so notified of the selection. All electrical tests shall be performed at normal room temperature.

18.1.1 **Caution:** It is recommended that the test apparatus be designed to afford the operator full protection in the performance of his duties. Reliable means of de-energizing and grounding the high-voltage circuit should be provided. It is particularly important to incorporate positive means of grounding the high-voltage section of dc test apparatus due to the likely presence of high-voltage capacitance charges at the conclusion of the test. See ANSI C39.5.

18.1.2 To eliminate damaging ozone and possible flashover along the line hose, there should be a sufficient flow of air into and around the line hose and an exhaust system to adequately remove ozone from the test machine. Consistent ozone cutting and checking during the test procedure should be cause to ascertain the adequacy of the exhaust system.

18.1.3 The equipment shall be inspected at least annually to ensure that the general condition of the equipment is acceptable and to verify the characteristics and accuracy of the test voltages. To ensure the continued accuracy of the test voltage, as indicated by the test equipment voltmeter, the test equipment shall be calibrated at least annually in accordance with the latest revision of Practice D2865.

18.1.4 *Electrodes:*

18.1.4.1 Test the entire area of each line hose, as nearly as practicable, between electrodes that apply the electric stress uniformly over the test area without producing corona at any point or mechanical strain in the material. The electrodes shall be of such dimensions and so placed as to avoid flashover at the edges. The inside electrode shall be a metal mandrel of the size specified in Table 2 and Table 3. The outer electrode may be a wet woolen blanket, metal foil, or a metal form with smoothly rounded edges and corners, shaped to fit the contour of the line hose without squeezing, pressing into, or distorting the rubber, extending to within 12.7 mm (½ in.) of the edge of the lip of

⁵ Data available in ASTM Research Report. Request RR F18-1000.

the hose, and extending to approximately 152 mm (6 in.) of the end of the hose. If the hose has a connector end, the form should extend to within 12.7 mm (½ in.) of the connector end.

NOTE 7—These end clearances are intended to serve as a guide and under some conditions may have to be increased to prevent flashover.

18.1.4.2 When Style C and D line hose is tested, the outer electrode shall fit around the outside diameter of the hose but not on the extended lip. A 152-mm (6-in.) uncovered area shall exist at each end of the hose. Before applying the metal electrodes, the inner and outer surfaces of the hose should be moistened slightly for ac testing. (See Fig. 2.)

18.1.5 AC Voltage Supply and Regulation:

18.1.5.1 Use test equipment in both the proof test and flashover tests capable of supplying an essentially stepless and continuously variable voltage to the test specimen. Motor-driven regulating equipment is convenient and tends to provide uniform rate-of-rise to the test voltage. Protect the test apparatus by an automatic circuit-breaking device designed to open promptly on the current produced by breakdown of a specimen under test. This circuit breaking device should be designed to protect the test equipment under any conditions of short circuit.

18.1.5.2 The desired test voltage may be most readily obtained from a step-up transformer energized from a variable low-voltage source. The transformer and its control equipment shall be of such size and design that, with the test specimen in the circuit, the crest factor (ratio of maximum to mean effective) of the test voltage shall differ by not more than 5 % from that of a sinusoidal wave over the upper half of the range of test voltage.

18.1.5.3 Measure the correct rms value of the actual sinusoidal voltage wave-form applied to the line hose by one of the following methods: (1) a voltmeter used in conjunction with a calibrated instrument transformer connected directly across the high-voltage circuit, (2) a calibrated electrostatic voltmeter connected directly across the high-voltage circuit, (3) a voltmeter connected to a tertiary coil in the test transformer, provided it has been demonstrated that the assigned ratio of transformation does not change appreciably with load, and (4)

an ac meter connected in series with appropriate high-voltage circuit. The accuracy of the voltage-measuring circuit shall be within $\pm 2\%$ of full scale.

NOTE 8—A voltmeter connected to the low-voltage side of the testing transformer may be used only if the ratio of transformation has been properly determined and is known not to change appreciably with load. A calibrated sphere gap may be used to check the accuracy of the voltage as indicated by the voltmeter.

18.1.5.4 Check the crest factor by the reading of a peakreading voltmeter connected directly across the high-voltage circuit; or, if an electrostatic voltmeter or a voltmeter in conjunction with an instrument potential transformer is connected across the high-voltage circuit, a standard sphere gap may be sparked over and the corresponding voltage compared with the reading of the rms voltmeter.

18.1.6 DC Voltage Supply and Regulation:

18.1.6.1 Obtain the dc proof-test voltage from a dc source capable of supplying the required voltage. The peak-to-peak ac ripple component of the dc proof-test voltage shall not exceed 2 % of the average voltage value under no-load conditions.

18.1.6.2 Measure the dc proof-test voltage by a method that provides the average value of the voltage applied to the line hose. It is recommended that this voltage be measured by the use of a dc meter connected in series with appropriate high-voltage type resistors across the high-voltage circuit. An electrostatic voltmeter of proper range may be used in place of the dc meter-resistor combination. The accuracy of the voltage measuring circuit shall be within $\pm 2\%$ of full scale.

18.1.7 Procedure—Apply the voltage at a rate-of-rise of approximately 1000 V/s ac or 3000 V/s dc until proof-test voltage is reached or failure occurs. The proof-test values shall be in accordance with Table 2 or Table 3.

18.2 Electrical Flashover Test:

18.2.1 Electrodes—The inside electrodes shall be of the size specified in Table 2 and Table 3. The flashover ground point shall be a 9.5-mm (3/8-in.) rod 304 mm (12 in.) shorter than the

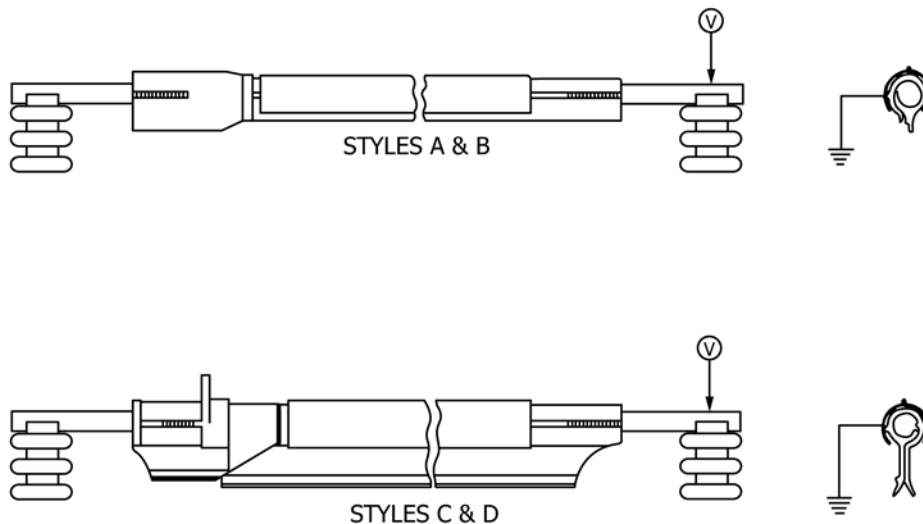

FIG. 2 Proof-Test Electrodes

length of hose being tested. The inside mandrel shall be energized and the rod placed in the hose lips shall be grounded. (See Fig. 3.)

18.2.2 *Procedure*—Apply the voltage at a rate-of-rise of approximately 1000 V/s ac or 3000 V/s dc until flashover occurs. The flashover values shall be in accordance with Table 2 or Table 3.

18.3 *Ozone Resistance Tests:*

18.3.1 *Electrodes*—The inside mandrel shall be of the size specified in Table 2. Bend the mandrel to a 90-deg angle from the base with a radius of 178 mm (7 in.). The mandrel shall be electrically grounded. After the hose is in test position, place a metal electrode around the curved portion of the hose on the mandrel. An energizing lead from the bus may be attached to the electrode by means of a test clip.

18.3.2 *Voltage Source*—Energize the outer electrode at 15 kV ac (rms) from a stable 60-Hz source in accordance with 18.1.5.

18.3.3 *Procedure*—Determine the ozone resistance of the specimen qualitatively by inspection, after a 1-h exposure period in the test apparatus at the 15-kV potential. Select and test at least two specimens of hose.

NOTE 9—The rate of ozone degradation is inversely proportional to the relative humidity of the surrounding air. Empirical data indicate that visible ozone effects will be evident over a broad range of ambient humidities under these test conditions.

19. Chemical and Physical Tests

19.1 *Chemical Tests:*

19.1.1 Determine the composition of the rubber hydrocarbon portion of Type I line hose in accordance with the test methods in Test Methods D297.

19.2 *Physical Tests:*

19.2.1 Physical tests shall be performed to determine the physical requirements specified in 7.1. The hose samples should be conditioned by storing in a relaxed position for 24 h at room temperature.

19.2.2 Tensile strength and elongation and tension set tests shall be performed in accordance with Test Methods D412. The test specimen shall conform in dimensions to Die C. The elongation in the tension set shall be 150 %.

19.2.3 The tear resistance test shall be performed in accordance with Test Method D624. The test specimen shall conform in dimensions to Die C of Test Method D624.

19.2.4 Accelerated aging tests shall be performed in accordance with Test Method D573. After being subjected to a temperature of 70 ± 1°C (158 ± 2°F) in circulating air for 7 days, the tensile strength of the specimen shall not be less than 75 % of the original.

19.2.5 The moisture absorption test shall be performed in accordance with Test Method D570, using the 24-h immersion procedure.

20. Keywords

20.1 electrical insulating line hose; lineman; lineman protective equipment

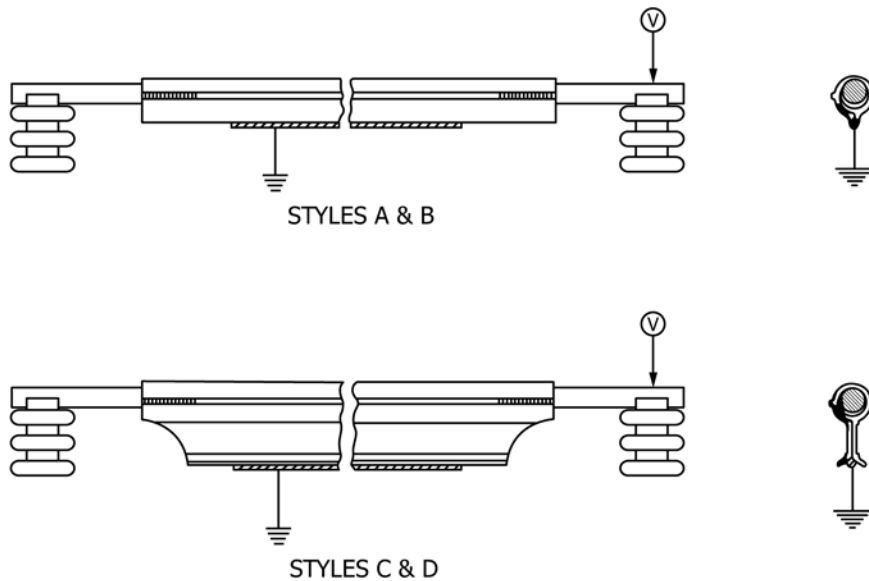

FIG. 3 Flashover Test Electrodes

 **D1050 – 05 (2011)**

ASTM International takes no position respecting the validity of any patent rights asserted in connection with any item mentioned in this standard. Users of this standard are expressly advised that determination of the validity of any such patent rights, and the risk of infringement of such rights, are entirely their own responsibility.

This standard is subject to revision at any time by the responsible technical committee and must be reviewed every five years and if not revised, either reapproved or withdrawn. Your comments are invited either for revision of this standard or for additional standards and should be addressed to ASTM International Headquarters. Your comments will receive careful consideration at a meeting of the responsible technical committee, which you may attend. If you feel that your comments have not received a fair hearing you should make your views known to the ASTM Committee on Standards, at the address shown below.

This standard is copyrighted by ASTM International, 100 Barr Harbor Drive, PO Box C700, West Conshohocken, PA 19428-2959, United States. Individual reprints (single or multiple copies) of this standard may be obtained by contacting ASTM at the above address or at 610-832-9585 (phone), 610-832-9555 (fax), or service@astm.org (e-mail); or through the ASTM website (www.astm.org). Permission rights to photocopy the standard may also be secured from the Copyright Clearance Center, 222 Rosewood Drive, Danvers, MA 01923, Tel: (978) 646-2600; <http://www.copyright.com/>