



# Standard Test Method for Resistance of Transparent Plastics to Surface Abrasion<sup>1</sup>

This standard is issued under the fixed designation D1044; the number immediately following the designation indicates the year of original adoption or, in the case of revision, the year of last revision. A number in parentheses indicates the year of last reapproval. A superscript epsilon ( $\epsilon$ ) indicates an editorial change since the last revision or reapproval.

*This standard has been approved for use by agencies of the U.S. Department of Defense.*

## 1. Scope\*

1.1 This test method describes a procedure for estimating the resistance of transparent plastics to one kind of surface abrasion by measuring the change in optical properties.

1.2 Abrasive damage is visually judged and numerically quantified by calculating the difference in haze percentage in accordance with Test Method **D1003** between an abraded and unabraded specimen.

1.3 CS-10F wheels manufactured between October 2002 and September 2004 have been found to give different results than historical values. Comparisons of data using these wheels should be made with caution. Results using wheels made after September 2004 have agreed with those obtained before October 2002.

1.4 The values stated in SI units are to be regarded as standard. The values given in parentheses are for information only.

NOTE 1—This test method is equivalent in the measurement of resistance to abrasion of **ISO 3537**, Section 7 and **ISO 15082**, Section 11, but is not equivalent in any other measurement or section. This test method is not equivalent to **ISO 9352**, and results cannot be directly compared between the two methods.

NOTE 2—This test method is similar to **ANSI/SAE Z26.1**, Test 17.

NOTE 3—Prior attempts to employ the Taber Abraser for volume loss determinations of various plastics<sup>2</sup> have been unsuccessful because of excessively large coefficients of variation attributed to the data. Insufficient agreement among the participating laboratories has rendered the use of volume loss procedure inadvisable as an ASTM test method.

NOTE 4—For determining the resistance to abrasion of organic coatings by weight loss, reference is made to Test Method **D4060**, which uses more aggressive CS-10 or CS-17 abrasive wheels.

1.5 *This standard does not purport to address all of the safety concerns, if any, associated with its use. It is the responsibility of the user of this standard to establish appropriate safety and health practices and determine the applicability of regulatory limitations prior to use.*

<sup>1</sup> This test method is under the jurisdiction of ASTM Committee **D20** on Plastics and is the direct responsibility of Subcommittee **D20.10** on Mechanical Properties.

Current edition approved Sept. 1, 2013. Published September 2013. Originally approved in 1949. Last previous edition approved in 2008 as D1044 - 08<sup>e1</sup>. DOI: 10.1520/D1044-13.

<sup>2</sup> Supporting data are available from ASTM Headquarters. Request RR:D20-48 and RR:D20-1090.

## 2. Referenced Documents

### 2.1 ASTM Standards:<sup>3</sup>

**D1003** Test Method for Haze and Luminous Transmittance of Transparent Plastics

**D4000** Classification System for Specifying Plastic Materials

**D4060** Test Method for Abrasion Resistance of Organic Coatings by the Taber Abraser

**E691** Practice for Conducting an Interlaboratory Study to Determine the Precision of a Test Method

**G195** Guide for Conducting Wear Tests Using a Rotary Platform Abraser

### 2.2 ISO Standards:<sup>4</sup>

**ISO 3537** Road Vehicles—Safety Glazing Materials—Mechanical Tests

**ISO 9352** Plastics—Determination of Resistance to Wear by Abrasive Wheels

**ISO 15082** Road Vehicles—Tests for Rigid Plastic Safety Glazing Materials

### 2.3 ANSI Standards:<sup>4</sup>

**ANSI/SAE Z26.1** Safety Glazing Materials for Glazing Motor Vehicle and Motor Vehicle Equipment Operating on Land Highways—Abrasion Resistance, Test 17 (Plastics)

## 3. Terminology

### 3.1 Definitions:

3.1.1 *abrasion*—abrasive wear caused by displacement or rearrangement of a softer material due to rubbing or scuffing against hard sharp particles.

3.1.2 *haze*—In accordance with Test Method **D1003**, that percentage of transmitted light which in passing through the specimen deviates from the incident beam by forward scattering. For the purpose of this test method, only light flux deviating more than 0.044 rad (2.5°) on the average is considered to be haze.

<sup>3</sup> For referenced ASTM standards, visit the ASTM website, [www.astm.org](http://www.astm.org), or contact ASTM Customer Service at [service@astm.org](mailto:service@astm.org). For *Annual Book of ASTM Standards* volume information, refer to the standard's Document Summary page on the ASTM website.

<sup>4</sup> Available from American National Standards Institute (ANSI), 25 W. 43rd St., 4th Floor, New York, NY 10036, <http://www.ansi.org>.

\*A Summary of Changes section appears at the end of this standard

3.1.3 *reface*—preparation of an abrasive wheel on a conditioning stone prior to use in testing.

3.1.4 *wheel*—an abrasive wheel consisting of hard particles (aluminum oxide) embedded in resilient binder.

4. Significance and Use

4.1 Transparent plastic materials, when used as windows or enclosures, are subject to wiping and cleaning; hence the maintenance of optical quality of a material after abrasion is important. It is the purpose of this test method to provide a means of estimating the resistance of such materials to this type and degree of abrasion.

4.2 Although this test method does not provide fundamental data, it is suitable for grading materials relative to this type of abrasion in a manner which correlates with service.

4.3 Comparison of interlaboratory data or the specification of a “haze” value has no significance if the hazemeter requirements given in 5.4 are not used. This is because light diffused from the surface of a Taber track is scattered at a narrow angle (Fig. 1 and Fig. 2) while light diffused internally by a specimen is scattered at a wide angle. In many hazemeters, when a diaphragm is inserted to limit the light beam to the width of the abraded track, the specular beam at the exit port becomes smaller. The dark annulus will then be greater than the

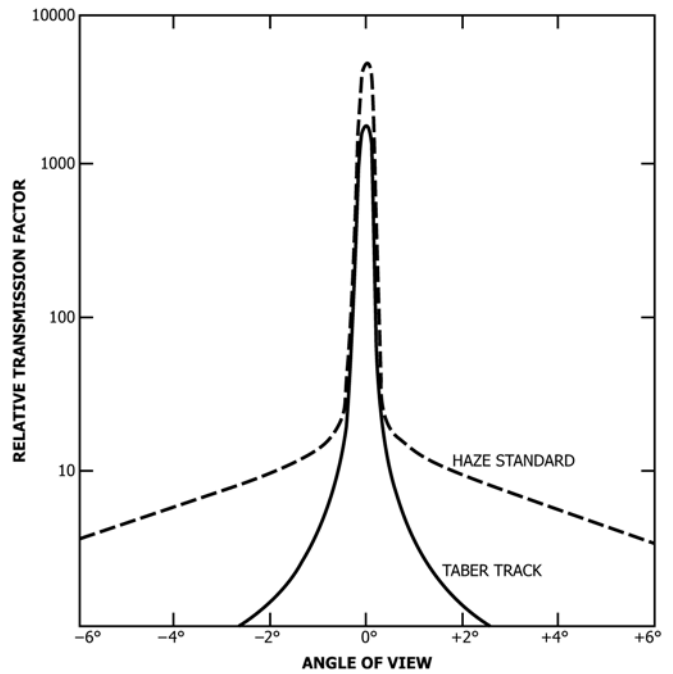

NOTE 1—This graph shows goniophotometric curves for Taber abraded tracks. The specular angle of transmission is at 180°. FIG. 2 Light Scattering from Surface of Abraded Tracks (Graph)

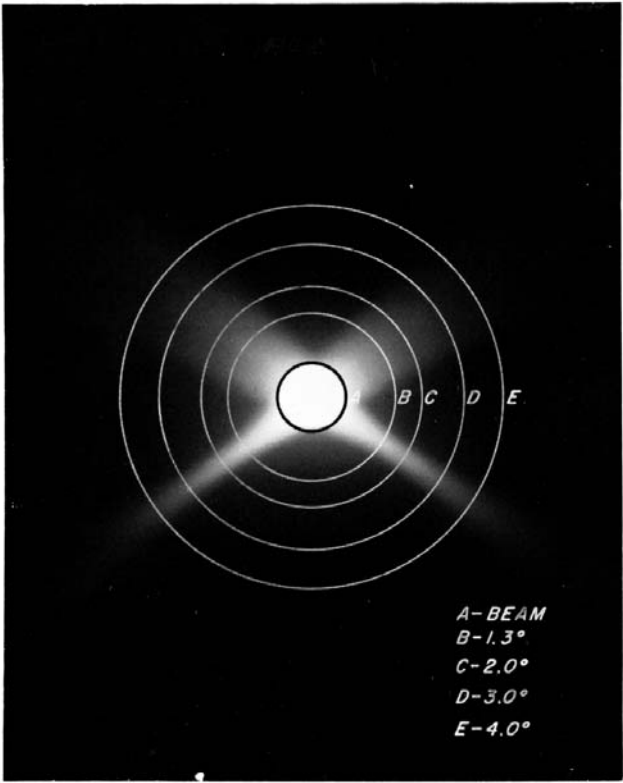

NOTE 1—This photograph shows light pattern of the scattering from the surface of a Taber abraded specimen. The circles show how increasing the 1.3° dark annulus dramatically changes the amount of light impacting the sphere wall.

FIG. 1 Light Scattering from Surface of Abraded Tracks (Photograph)

0.023 ± 0.002 rad (1.3 ± 0.1°) requirements of Test Method D1003. Since a large percentage of the narrow-angle forward-scattered light will not impinge on the sphere wall, “haze” readings become smaller. For hazemeters that have not been properly adjusted, the magnitude of this reduction is dependent both on the integrating sphere diameter and the reduction of the entrance beam.

4.4 For many materials, there may be a specification that requires the use of this test method, but with some procedural modifications that take precedence when adhering to the specification. Therefore, it is advisable to refer to that material specification before using this test method. Table 1 of Classification System D4000 lists the ASTM materials standards that currently exist.

4.5 For some materials, abrasion tests utilizing the Taber abraser may be subject to variation due to changes in the abrasive characteristics of the wheel during testing.

4.5.1 Depending on abradant type and test specimen, the wheel surface may change (that is, become clogged) due to the transfer of coating or other materials from test specimens and must be cleaned at frequent intervals.

4.5.2 The type of material being tested and the number of test cycles being run is known to sometimes influence the temperature of the running surface of the wheel with an effect on the final haze measurement. To reduce any variability due to this temperature effect, stabilize the wheels surface temperature prior to performing actual measurements. This shall be accomplished by conducting multiple refacings on an ST-11 refacing stone, followed by a test on the sample material to be tested (with results to be discarded).

## 5. Apparatus

5.1 *Abrader*—The Taber abramer or its equivalent, as described in Guide **G195** and consisting of the following elements:

5.1.1 A horizontal turntable platform; comprised of a rubber pad, clamp plate, and nut to secure the specimen to the turntable.

5.1.2 A motor capable of rotating the turntable platform at a speed of either  $72 \pm 2$  r/min for 110v/60Hz or  $60 \pm 2$  r/min for 230v/50Hz.

5.1.3 A pair of pivoted arms, to which the abrasive wheels and auxiliary masses (if used) would be attached; loads of 500 or 1000 gf on the wheels are obtained by use of changeable weights.

NOTE 5—Without auxiliary masses or counterweights applied, each arm will apply a load against the specimen of 250 gf per wheel (exclusive of the mass of the wheel itself).

5.1.4 A vacuum suction system and vacuum pick-up nozzle to remove debris and abrasive particles from the specimen surface during testing. The height of the vacuum pick-up nozzle shall be adjustable, and the nozzle openings shall be 11 mm ( $7/16$  in.) in diameter.

NOTE 6—The nominal nozzle openings are 8 mm ( $5/16$  in.) and can be enlarged following the instructions shown in **Appendix X2**.

5.1.5 A counter to record the number of cycles (revolutions) made by the turntable platform.

5.2 *Refacing Stone*—The ST-11 refacing stone (or equivalent) shall be used for refacing the abrasive wheels. It is important that the turntable platform runs true on the abramer and that the refacing stone lies flat on the turntable platform.

5.3 *Abrasive Wheels*—The grade of wheel designated CS-10F<sup>5</sup> shall be used, and shall meet the following requirements at the time of the test:

5.3.1 The wheel shall be  $12.7 \pm 0.3$  mm wide and have an external diameter of  $51.9 \pm 0.5$  mm when new, and in no case less than 44.4 mm, and

5.3.2 The wheel shall not be used after the date stamped on it.

5.4 *Hazemeter*—An integrating sphere photoelectric photometer, as described in Test Method **D1003**, shall be used to measure the light scattered by the abraded track. If haze measurements are made with other devices or by other methods, a correlation shall be established with the results obtained with the apparatus and method described in Test Method **D1003**.

5.4.1 An aperture or diaphragm shall be centrally inserted in the haze measuring apparatus to center the light beam on the abraded track and limit it to a diameter of  $7 \pm 1$  mm (0.28  $\pm$  0.04 in.) at the specimen.

5.4.2 When the reduced light beam is unobstructed by a specimen, its cross section at the exit port shall be approxi-

mately circular, sharply defined, uniformly bright, and concentric within the exit port, leaving an annulus of  $0.023 \pm 0.002$  rad ( $1.3 \pm 0.1^\circ$ ) subtended at the entrance port.

NOTE 7—Uniformity of the light intensity is usually checked by observing the beam through thin bond paper placed at the exit port.

NOTE 8—Forward-scattering glass standards<sup>6</sup> can be used to check that the optical system of the hazemeter is properly adjusted.

5.5 *Specimen Holder*—A suitable holder shall be used to permit positioning the abraded specimen on the hazemeter so that the light beam is centered in the abraded track and the specimen is flush at the measurement port.

## 6. Test Specimens

6.1 The test specimens shall be clean, transparent disks approximately 100 mm in diameter or plates approximately 100 mm square, having both surfaces substantially plane and parallel. They may be cut from sheets or molded in thicknesses up to 12.7 mm ( $1/2$  in.). A 6.3-mm ( $1/4$ -in.) hole shall be centrally drilled in each specimen. Three such specimens shall be tested per sample, except for interlaboratory or specification tests when ten specimens shall be tested.

## 7. Calibration

7.1 Verify calibration of the Taber abramer as directed by the equipment manufacturer (see **Appendix X1**).

## 8. Conditioning

8.1 *Conditioning*—Unless otherwise specified, condition the test specimens at  $23 \pm 2^\circ\text{C}$  ( $73.4 \pm 3.6^\circ\text{F}$ ) and  $50 \pm 5\%$  relative humidity for not less than 40 h prior to test. In cases of disagreement, the tolerances shall be  $\pm 1^\circ\text{C}$  ( $\pm 1.8^\circ\text{F}$ ) and  $\pm 2\%$  relative humidity.

8.2 *Test Conditions*—Conduct tests in the standard laboratory atmosphere of  $23 \pm 2^\circ\text{C}$  ( $73.4 \pm 3.6^\circ\text{F}$ ) and  $50 \pm 5\%$  relative humidity, unless otherwise specified. In cases of disagreements, the tolerances shall be  $\pm 1^\circ\text{C}$  ( $\pm 1.8^\circ\text{F}$ ) and  $\pm 2\%$  relative humidity.

NOTE 9—The change in percent of haze significantly worsens when humidity levels are less than 45 %.

## 9. Standardization of Abrading Wheels

9.1 To ensure that the abrading function of the wheels is maintained at a constant level, prepare the abrading wheels prior to each test.

9.1.1 Mount the wheels on their respective flange holders, taking care not to handle them by their abrasive surfaces.

9.1.2 Select the load to be used and affix it to the abramer. If no load is specified, use a load of 500 gf (per wheel).

9.1.3 Mount an ST-11<sup>7</sup> refacing stone (or equivalent) on the turntable, and secure using the nut.

9.1.4 Lower the vacuum nozzle and adjust its height to within 0.8 to 1.6 mm ( $1/32$  to  $1/16$  in.) of the refacing stone. Set the vacuum suction force to 100.

<sup>5</sup> The sole source of supply of the apparatus known to the committee at this time is Taber Industries, 455 Bryant Street, North Tonawanda, NY 14120. If you are aware of alternative suppliers, please provide this information to ASTM International Headquarters. Your comments will receive careful consideration at a meeting of the responsible technical committee,<sup>1</sup> which you may attend.

<sup>6</sup> Calibrated plastic haze standards are available from BYK-Gardner, Inc., 9104 Guilford Road, Columbia, MD 21046.

<sup>7</sup> The opposing sides of ST-11 refacing stones manufactured prior to July 2010 were a duplex stone with one side 180 grit (referenced as the fine side) and the opposite side 80 grit. Use only the fine side.

9.1.5 Lower the arms so the wheels contact the surface of the ST-11 refacing stone.

9.2 Before abrading each specimen, reface the wheels for 25 cycles on the ST-11 refacing stone. After refacing, use a soft bristle, anti-static brush to lightly brush the wheel surfaces to remove any loose particulate matter before abrading a specimen. (**Warning**—Do not touch the running surface of the wheels after they are refaced. New wheels or wheels trued using a diamond tool refacer, must first be broken in with 100 cycles on the ST-11 refacing stone followed by a test on the material to be evaluated (results to be discarded).)

NOTE 10—A brush found suitable for this purpose has been described as follows: Having a width of two inches with tuft spacing of 0.25 inches, it is a soft-fiber, static-dissipative brush manufactured from an acrylic fiber (0.0015 inch filament diameter) that has been chemically bonded with a layer of copper sulfide to produce a resistance of 3–5 times  $10^{-4}$  ohms per centimetre.

NOTE 11—The fine side of the ST-11 refacing stone has a limited life and must be replaced after 7500 cycles (approximately 300 refacings).

9.2.1 A thin fin of wheel material will sometimes form on the left hand edge of the wheel as the main body of the wheel wears down. To remove, gently rub the edge of the wheel using a gloved finger. Avoid touching the running surface of the wheel.

9.2.2 The maximum allowed time between refacing and testing shall not exceed two minutes.

## 10. Procedure

10.1 Before testing, remove any protective masking material from the specimen. If required, clean the specimen using a practice recommended by the manufacturer or in accordance with 10.5. Handle test pieces by their edges to prevent contamination of their surfaces.

10.2 Place the unabraded specimen in the hazemeter sample holder with the side to be abraded facing the entrance port of the integrating sphere. Measure the haze percentage (initial haze) of the specimen at a minimum of four equally spaced points in the unabraded area. The results shall be averaged for each specimen.

NOTE 12—As an operational qualification step for the instrumental measurement of transmission haze, it is recommended to measure the haze percentage value with no sample present and verify that the reading of the hazemeter is 0. The sample holder must be removed during this measurement.

10.3 Mount the specimen on the abraser turntable platform with the side to be abraded facing up. The specimen shall be mounted at a  $45^\circ$  angle from the front of the machine (see Fig. 3). Secure using the clamp plate and nut.

10.4 Select the load to be used and affix it to the abraser. Lower the vacuum pick-up nozzle and adjust the height to within 0.8 to 1.6 mm ( $1/32$  to  $1/16$  in.) of the specimen surface. Set the counter to zero and program the appropriate number of cycles. Start the abraser and subject the specimen to abrasion for a selected number of cycles. Use an abrasion of 100 cycles with the 500 load, unless otherwise specified.

NOTE 13—If using a dual table abraser and the second table is not in use, mount a sample to that table, lower the vacuum pick-up nozzle and adjust the height as stated in 10.4.

NOTE 14—For plotting curves of light scattering versus cycles of abrasion, 10, 25, 50, and 100 cycles are recommended.

10.5 After abrasion, handle test pieces by their edges to prevent contamination of their surfaces. Clean the test specimen following the manufacturers recommendation. If none is specified, use the following method:

10.5.1 Using a soft bristle, anti-static brush, lightly brush off any debris adhered to the surface of the test specimen.

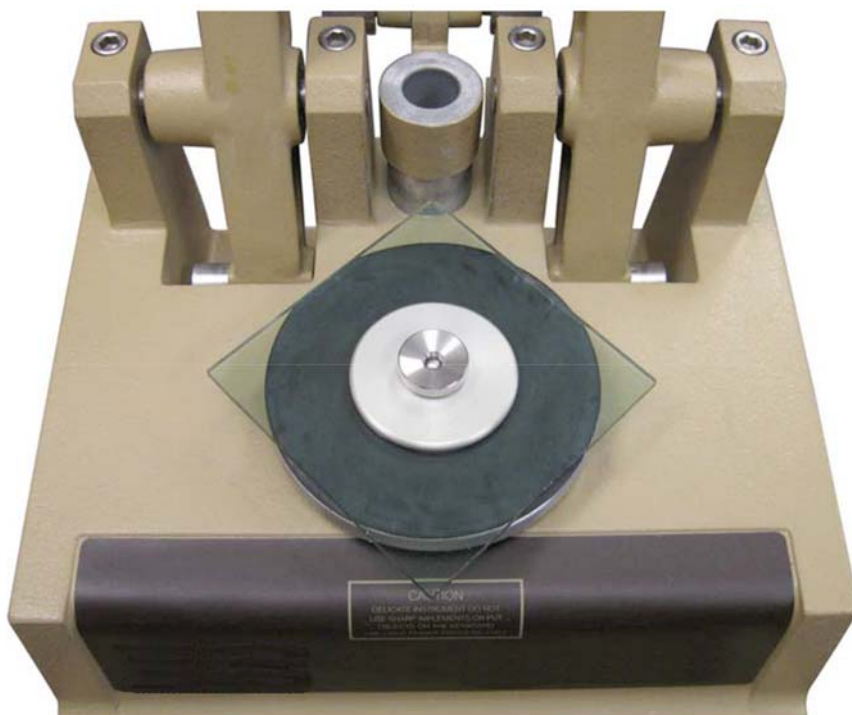

FIG. 3 Specimen Mounting

10.5.2 Using an Isopropyl alcohol (IPA) soaked lint free cloth, gently wipe both surfaces of the specimen in a linear motion to remove any remaining particulate. First wipe the specimen vertically, then wipe the specimen horizontally; and as a final cleaning step wipe the edges (see Fig. 4). For those materials where IPA influences the surface characteristics, or does not yield a satisfactory result, use a cleaning solution of water with a commercial (for example, dish-washing) detergent added, or a cleaning solution that is compatible with the sample. Rinse with deionized water, then dry by pressing lightly between two linen cloths or blow dry with clean air or nitrogen. Inspect to confirm there are no water spots or other residue before taking haze measurement.

10.6 Place the abraded specimen in the hazemeter sample holder with the abraded track against the entrance port of the integrating sphere (facing away from the light source). Measure the haze percentage of the transmitted light that is diffused by the abraded track (final haze) on at least four equally spaced intervals along the track. The results shall be averaged for each specimen. The specimen holder shall be positioned so that no portion of the light beam is within 1 mm of the inside or outside edge of the track.

10.6.1 Percent haze, as defined by Test Method D1003, is calculated as follows:

$$\text{haze} = [T_d / T_t] \times 100 \quad (1)$$

where:

$T_t$  = total transmittance

$T_d$  = diffuse transmittance

NOTE 15—Subjective comparisons may be made by visually comparing abraded specimens with a measured, abraded standard.

10.7 The initial haze percentage of the unabraded specimen determined by 10.2 shall be subtracted from the final haze percentage of the abraded sample as measured by 10.6. The difference represents the light scatter resulting from abrading the specimen.

## 11. Interpretation of Results

11.1 The lower the percent haze difference, the more resistant the specimen is to abrasive damage.

## 12. Report

12.1 Report the following information:

12.1.1 Change in percentage of haze as calculated by 10.7,

12.1.2 Number of specimens tested,

12.1.3 Load and the number of cycles used, if other than specified in 10.4,

12.1.4 Wheel cleaning interval(s), if clogging is an issue,

12.1.5 Temperature stabilization details (in accordance with 4.5.2), if applicable,

12.1.6 Cleaning solution used, if applicable,

12.1.7 Rotational speed of turntable platform,

12.1.8 Plot of the percentage of light scattered versus cycles abraded, if more than one number of cycles is used, and

12.1.9 Description of the integrating sphere photometer including: sphere geometry; exit light beam diameter with and without the diaphragm inserted; and location of the diaphragm in the light beam. Alternatively, report the make and model of the hazemeter used.

## 13. Precision and Bias

13.1 Table 1 is based on a round robin conducted in 2004, involving five materials tested by five laboratories. Each lab made six (6) determinations for each material and cycle combination. It should be noted that the test procedure used for the round robin involved higher reface cycles, and no consideration was given to the useful life of the ST-11 refacing stone.

13.1.1 In Table 1 for the materials indicated:

$S_r$  = pooled within-laboratories standard deviation of the mean for three or ten specimens,

$S_R$  = total among-laboratories standard deviation of the mean for three or ten specimens,

$r$  = 2.83  $S_r$  (see 13.2), and

$R$  = 2.83  $S_R$  (see 13.3).

Other materials may give somewhat different results.

13.2 *Repeatability*—In comparing two averages for the same material, obtained by the same operator using the same equipment on the same day, the average should be judged not equivalent if they differ by more than the  $r$  value for that material and condition.

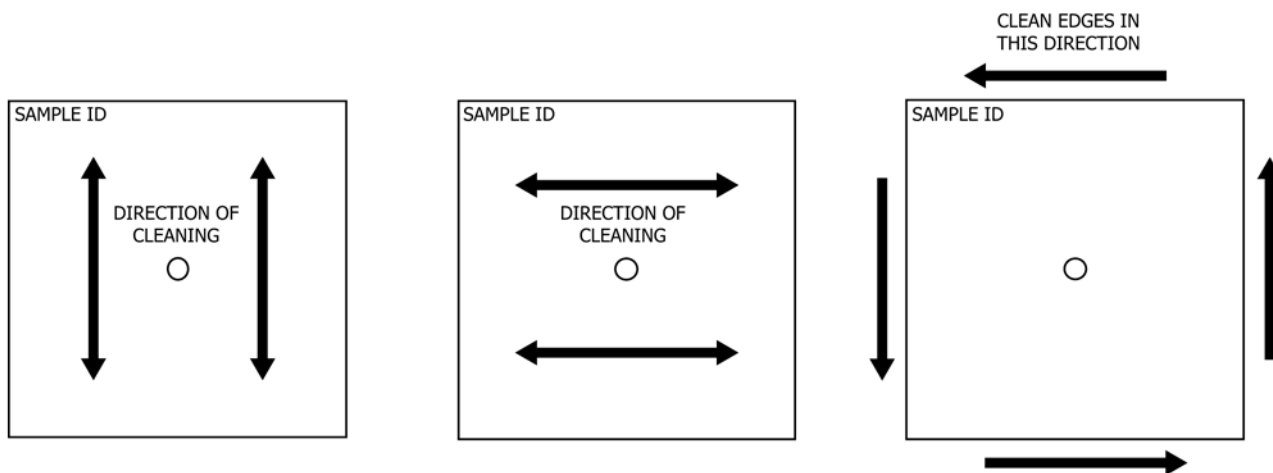

FIG. 4 Specimen Cleaning

TABLE 1 Precision Statement Based on Three Replicate Observations

Material	Number of Cycles	Mean	Values in Units of Percent Haze				
			$S_x$	$S_r$	$S_R$	$r$	$R$
Glass	1000	0.69	0.19	0.16	0.25	0.45	0.70
Polycarbonate—Coating 1	500	2.52	0.76	0.95	1.19	2.65	3.32
Polycarbonate—Coating 2	100	8.95	1.23	1.64	1.99	4.58	5.57
Polycarbonate—Coating 3	500	11.65	2.95	4.82	5.48	13.49	15.33
Polycarbonate—Coating 4	1000	2.82	0.83	0.93	1.22	2.61	3.42

13.3 *Reproducibility*—In comparing two averages for the same material, obtained by different operators using different equipment, the averages should be judged not equivalent if they differ by more than the  $R$  value for that material and condition.

13.4 The judgments in accordance with 13.2 and 13.3 will be correct in approximately 95 % of such comparisons.

13.5 For further information on the methodology used in this section, see Practice E691.

13.6 *Bias*—No statement is made about bias of this test method, as there is no absolute method available as a referee method.

14. Keywords

14.1 abrasion; haze; hazemeter; surface abrasion; Taber abraser

APPENDIXES

(Nonmandatory Information)

X1. CALIBRATION VERIFICATION

X1.1 To facilitate the verification of calibration of the Taber abraser, a kit is available<sup>5</sup> that provides a fast reliable system check. This kit is not meant as a substitute for regular instrument calibration. Procedures in the kit allow the user to verify:

X1.1.1 *Wheel Alignment and Tracking*—The wheels should be spaced equally on both sides from the wheel-mounting flange to the center of the specimen holder. When resting on the specimen, the wheels will have a peripheral engagement with the surface of the specimen, the direction of travel of the periphery of the wheels and of the specimen at the contacting portions being at acute angles, and the angles of travel of one wheel periphery being opposite to that of the other. Wheel internal faces shall be  $52.4 \pm 1.0$  mm apart and the hypothetical line through the two spindles shall be  $19.05 \pm 0.3$  mm away from the central axis of the turntable. (See Fig. X1.1)

X1.1.2 *Wheel Bearings Condition*—The Taber abraser wheel bearings should be able to rotate freely about their horizontal spindles and not stick when the wheels are caused to spin rapidly by a quick driving motion of the forefinger.

X1.1.3 *Vacuum Suction Force*—Air pressure in the suction device must not be lower than 137 millibar (55 inches of water column), as measured by a suction gauge.

NOTE X1.1—Vacuum suction force may be influenced by the condition of the collection bag, which must be emptied or replaced on a regular basis. Clean any debris that collects on the inside of the vacuum pick-up nozzle on a frequent basis. Any connection or seal leaks will also influence suction force.

X1.1.4 *Turntable Platform Position*—The vertical distance from the center of the pivot point of the Taber abraser arms to

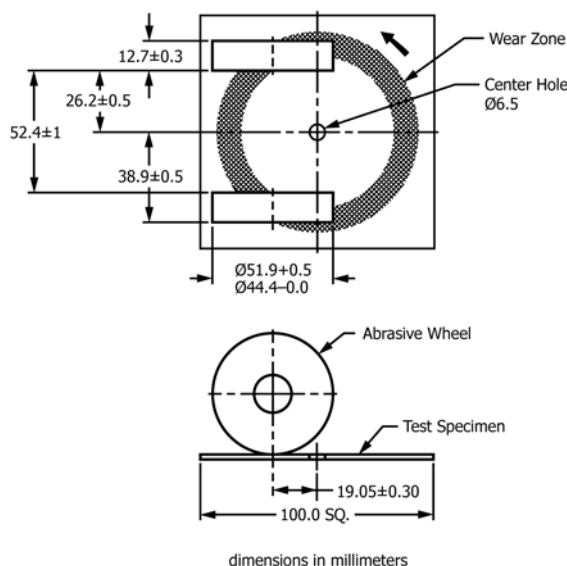

NOTE 1—This schematic shows the proper wheel position in relation to the turntable platform.

FIG. X1.1 Diagrammatic Arrangement of Taber Abraser Test Set-up

the top of the turntable platform should be approximately 25 mm. The turntable platform shall rotate substantially in a plane with a deviation at a distance of 1.6 mm (1/16 in.) from its periphery of not greater than  $\pm 0.051$  mm ( $\pm 0.002$  in.).

X1.1.5 *Turntable Speed*—The turntable should rotate at the speed stated in 5.1.2.

X1.1.6 *Load*—The accessory mass marked 500 g shall weigh  $250 \pm 1$  g and the accessory mass marked 1000 g shall weigh  $750 \pm 1$ g.

## X2. VACUUM PICKUP NOZZLE MODIFICATION

X2.1 The vacuum pick-up nozzle referenced in this test method has a larger diameter hole bore than the standard nozzle, 11 mm ( $7/16$  in.) versus 8 mm ( $5/16$  in.). A replacement nozzle is available, or the user can modify the vacuum nozzle according to the following instructions. (1) Secure the nozzle with the opening aligned under the drill bit so that the drilled

hole is perpendicular to the hole axis. (2) Using an 11-mm ( $7/16$ -in.) drill bit, enlarge the hole taking care not to drill completely through the vacuum pick-up nozzle. (3) Repeat for the second hole, so that the distance between the axes of the two openings is  $76.0 \pm 1.0$  mm. (See Fig. X2.1.)

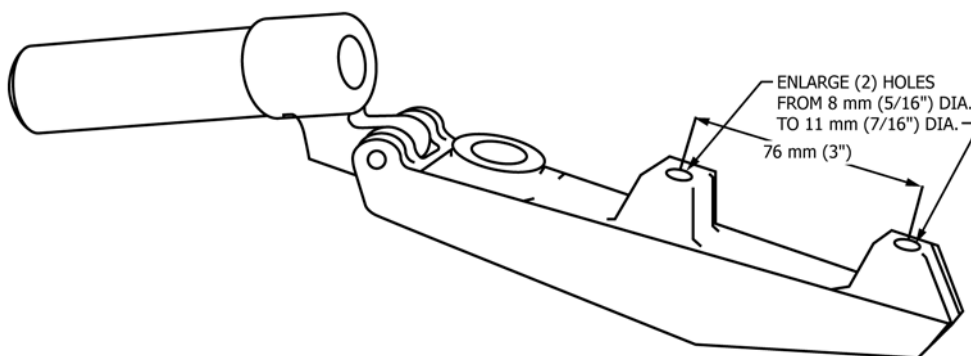

NOTE 1—Remove any burrs prior to use.

FIG. X2.1 Schematic of Modified Vacuum Pick-Up Nozzle

## SUMMARY OF CHANGES

Committee D20 has identified the location of selected changes to this standard since the last issue (D1044 - 08<sup>e1</sup>) that may impact the use of this standard. (September 1, 2013)

(1) Deleted erroneous statement from Note 4 claiming poor reproducibility of Test Method D4060.  
 (2) Deleted Practice D618 reference from 2.1 and added ASTM Guide G195; and added ISO 15082 to 2.2.  
 (3) Eliminated description of fine side of ST-11 refacing stone from 5.2. (Beginning in July 2012, ST-11 stones were manufactured with both sides considered “fine”).  
 (4) Inserted Footnote 7.  
 (5) Removed reference to Practice D618 in 8.1 (relative humidity tolerance changed in 2008 revision of Practice D618 and no longer matches  $\pm 5\%$ ).  
 (6) Corrected the limited life of the ST-11 refacing stone in Note 11 from 10,000 to 7,500 cycles.  
 (7) Update cleaning procedure prior to abrasion by referencing 10.5 in 10.1.

(8) Subsection 10.3 was updated so specimens are mounted at a 45° angle (added Fig. 3). (This change was made because the abrading wheels may scuff (skid on) the specimen when the turntable platform first starts to rotate. Rotating the specimens 45° will exclude this unintended damage from the haze measurement.)  
 (9) Updated cleaning instructions in 10.5.2 so specimens are wiped in a linear fashion and edges cleaned (added Fig. 4). Also permitted using a cleaning solution of water and commercial detergent; and included rinsing, drying, and inspecting.  
 (10) Renamed plasma coating to Coating 4 in Table 1.  
 (11) Replaced Fig. X1.1 with new image.

*ASTM International takes no position respecting the validity of any patent rights asserted in connection with any item mentioned in this standard. Users of this standard are expressly advised that determination of the validity of any such patent rights, and the risk of infringement of such rights, are entirely their own responsibility.*

*This standard is subject to revision at any time by the responsible technical committee and must be reviewed every five years and if not revised, either reapproved or withdrawn. Your comments are invited either for revision of this standard or for additional standards and should be addressed to ASTM International Headquarters. Your comments will receive careful consideration at a meeting of the responsible technical committee, which you may attend. If you feel that your comments have not received a fair hearing you should make your views known to the ASTM Committee on Standards, at the address shown below.*

*This standard is copyrighted by ASTM International, 100 Barr Harbor Drive, PO Box C700, West Conshohocken, PA 19428-2959, United States. Individual reprints (single or multiple copies) of this standard may be obtained by contacting ASTM at the above address or at 610-832-9585 (phone), 610-832-9555 (fax), or [service@astm.org](mailto:service@astm.org) (e-mail); or through the ASTM website ([www.astm.org](http://www.astm.org)). Permission rights to photocopy the standard may also be secured from the Copyright Clearance Center, 222 Rosewood Drive, Danvers, MA 01923, Tel: (978) 646-2600; <http://www.copyright.com/>*