



Standard Test Methods for Evaluating Properties of Wood-Base Fiber and Particle Panel Materials¹

This standard is issued under the fixed designation D1037; the number immediately following the designation indicates the year of original adoption or, in the case of revision, the year of last revision. A number in parentheses indicates the year of last reapproval. A superscript epsilon (ϵ) indicates an editorial change since the last revision or reapproval.

This standard has been approved for use by agencies of the U.S. Department of Defense.

INTRODUCTION

The test methods presented herein have been developed and are presented to serve two distinct purposes. They are divided into two parts.

Part A. General Test Methods for Evaluating the Basic Properties of Wood-Base Fiber and Particle Panel Materials—Part A is for use in obtaining basic properties suitable for comparison studies with other materials of construction. These refined test methods are applicable for this purpose to all materials covered by Definitions **D1554**.

Part B. Acceptance and Specification Test Methods for Hardboard—Part B is for specific use in specifications for procurement and acceptance testing of hardboard. These test methods are generally employed for those purposes in the industry. By confining their intended use as indicated, it has been possible to achieve adequate precision of results combined with economy and speed in testing, which are desirable for specification use.

The choice between a particular test method and its alternative should be made with a full understanding of the intended purpose of each, because values obtained from tests may, in some cases, differ. Of the test methods presented in both parts, some have been in generally accepted use for many years, some are modifications and refinements of previously developed test methods, and some are more recent developments. Where test methods are suitable for more than one of the purposes, they are delineated in Part A, but not repeated in Part B. It is the intent that reference to the appropriate section of the test method shall suffice in specifications developed for the different materials.

1. Scope

1.1 *Part A—General Test Methods for Evaluating the Basic Properties of Wood-Base Fiber and Particle Panel Materials.* These test methods cover the determination of the properties of wood-base fiber and particle panel materials that are produced as mat-formed panels such as particleboard, medium-density fiberboard, hardboard, and oriented strand board.

¹ These test methods are under the jurisdiction of ASTM Committee **D07** on Wood and are the direct responsibility of Subcommittee **D07.03** on Panel Products.

Current edition approved May 1, 2012. Published June 2012. Originally approved in 1949. Last previous edition approved in 2006 as D1037 – 06a. DOI: 10.1520/D1037-12.

	Section
Significance and Use	3
Apparatus	4
Test Specimens	5
Moisture Content and Conditioning Requirements	6
Accelerated Aging	7
Size, Physical Properties and Appearance of Panels	8
Static Bending	9
Tension Parallel to Surface	10
Tension Perpendicular to Surface	11
Compression Parallel to Surface	12
<i>Fastener Holding Tests:</i>	
Lateral Nail Resistance	13
Nail Withdrawal	14
Nail-Head Pull-Through	15
Direct Screw Withdrawal	16
Hardness	17
Hardness Modulus	18

	Section
Shear in the Plane of the Panel	19
Glue-Line Shear (Block Type)	20
Falling Ball Impact	21
Abrasion Resistance by the U.S. Navy Wear Tester	22
<i>Moisture Tests:</i>	
Water Absorption and Thickness Swelling	23
Linear Expansion with Change in Moisture Content	24
Cupping and Twisting	25
Interlaminar Shear	26
Edgewise Shear	27
Compression-Shear	28

1.2 *Part B—Acceptance and Specification Test Methods for Hardboard.* The methods for Part B provide test procedures for measuring the following properties of hardboard:

	Section
Thickness	32
Modulus of Rupture	33
Tension Strength Parallel to Surface	34
Tension Strength Perpendicular to Surface	35
Water Absorption and Thickness Swelling	36
Moisture Content and Specific Gravity	37

1.3 There are accepted basic test procedures for various fundamental properties of materials that may be used without modification for evaluating certain properties of wood-based fiber and particle panel materials. These test methods are included elsewhere in the *Annual Book of ASTM Standards*. The pertinent ones are listed in Table 1. A few of the test methods referenced are for construction where the wood-base materials often are used.

1.4 The values stated in inch-pound units are to be regarded as the standard. The SI equivalents are approximate in many cases. 1 in. = 25.4 mm, 1 lbf = 4.45 N.

1.5 *This standard does not purport to address all of the safety concerns, if any, associated with its use. It is the responsibility of the user of this standard to establish appropriate safety and health practices and determine the applicability of regulatory limitations prior to use.*

2. Referenced Documents

2.1 *ASTM Standards:*²

- [C273 Test Method for Shear Properties of Sandwich Core Materials](#)
- [D143 Test Methods for Small Clear Specimens of Timber](#)
- [D905 Test Method for Strength Properties of Adhesive Bonds in Shear by Compression Loading](#)
- [D1554 Terminology Relating to Wood-Base Fiber and Particle Panel Materials](#)
- [D2395 Test Methods for Density and Specific Gravity \(Relative Density\) of Wood and Wood-Based Materials](#)
- [D2915 Practice for Sampling and Data-Analysis for Structural Wood and Wood-Based Products](#)
- [D3043 Test Methods for Structural Panels in Flexure](#)
- [D3501 Test Methods for Wood-Based Structural Panels in Compression](#)
- [D4442 Test Methods for Direct Moisture Content Measurement of Wood and Wood-Base Materials](#)

² For referenced ASTM standards, visit the ASTM website, www.astm.org, or contact ASTM Customer Service at service@astm.org. For *Annual Book of ASTM Standards* volume information, refer to the standard's Document Summary page on the ASTM website.

TABLE 1 Basic Test Procedures for Evaluating Properties of Wood Base-Fiber and Particle Panel Materials

ASTM Designation	Test Methods for
C177	Steady-State Heat-Flux Measurements and Thermal Transmission Properties by Means of the Guarded-Hot-Plate Apparatus ^A
C209	Cellulosic Fiber Insulating Board ^A
C236	Steady-State Thermal Performance of Building Assemblies by Means of the Guarded Hot Box ^A
C384	Impedance and Absorption of Acoustical Materials by the Impedance Tube Method ^A
C423	Sound Absorption and Sound Absorption Coefficients by the Reverberation Room Method ^A
D149	Dielectric Breakdown Voltage and Dielectric Strength of Solid Electrical Insulating Materials at Commercial Power Frequencies ^B
D150	A-C Loss Characteristics and Permittivity (Dielectric Constant) of Solid Electrical Insulating Materials ^B
D257	D-C Resistance or Conductance of Insulating Materials ^B
D495	High-Voltage, Low-Current, Dry Arc Resistance of Solid Electrical Insulation ^B
D1666	Conducting Machining Tests of Wood and Wood-Base Materials ^C
D1761	Mechanical Fasteners in Wood ^C
E72	Conducting Strength Tests of Panels for Building Construction ^D
E84	Surface Burning Characteristics of Building Materials ^D
E90	Laboratory Measurement of Airborne Sound Transmission Loss of Building Partitions ^A
E96	Water Vapor Transmission of Materials ^A
E97	Directional Reflectance Factor, 45-deg 0-deg, of Opaque Specimens by Broad-Band Filter Reflectometry ^E
E119	Fire Tests of Building Construction and Materials ^D
E136	Behavior of Materials in a Vertical Tube Furnace at 750°C ^D
E152	Fire Tests of Door Assemblies ^D
E162	Surface Flammability of Materials Using a Radiant Heat Energy Source ^D
E661	Performance of Wood and Wood-Based Floor and Roof Sheathing Under Concentrated Static and Impact Loads ^D
E662	Specific Optical Density of Smoke Generated by Solid Materials ^D
E906	Heat and Visible Smoke Release Rates for Materials and Products ^D

^A *Annual Book of ASTM Standards*, Vol 04.06.

^B *Annual Book of ASTM Standards*, Vol 10.01.

^C *Annual Book of ASTM Standards*, Vol 04.10.

^D *Annual Book of ASTM Standards*, Vol 04.07.

^E *Annual Book of ASTM Standards*, Vol 14.02.

- [E4 Practices for Force Verification of Testing Machines](#)
- [E691 Practice for Conducting an Interlaboratory Study to Determine the Precision of a Test Method](#)

PART A—GENERAL TEST METHODS FOR EVALUATING THE BASIC PROPERTIES OF WOOD-BASE FIBER AND PARTICLE PANEL MATERIALS

3. Significance and Use

3.1 These test methods cover small-specimen tests for wood-base fiber and particle panel materials that are made to provide:

3.2 Data for comparing the mechanical and physical properties of various materials,

3.3 Data for determining the influence on the basic properties of such factors as raw material and processing variables, post-treatments of panels, and environmental influences, and

3.4 Data for manufacturing control, product research and development, and specification acceptance.

3.5 Not all the tests outlined in these test methods may be necessary to evaluate any particular panel for any specified use. In each instance, therefore, it will be necessary to determine which tests shall be made.

4. Apparatus

4.1 *Testing Machine*—For strength and fastener holding tests, any standard testing machine (see **Note 1**) capable of applying and measuring the load with an error not to exceed $\pm 1.0\%$ shall be used as provided in Practices **E4**.

NOTE 1—Some testing machines operated at speeds allowed in these test procedures without proper damping devices or in need of adjustment may yield values in error because of “follow-through” due to mass inertia effects in the weighing system. Care must be exercised in the selection of testing machines so that values obtained from test are not in error more than the amount stipulated.

5. Test Specimens

5.1 The number of specimens to be chosen for test and the method of their selection depend on the purpose of the particular tests under consideration, so that no general rule can be given to cover all instances. It is recommended that whenever possible, a sufficient number of tests be made to permit statistical treatment of the test data (see **Note 2**). In the evaluation of a panel material, specimens for test should be obtained from a representative number of panels. In properties reflecting differences due to the machine direction of the panel, specimens from each panel shall be selected both with the long dimension parallel to the long dimension of the panel, and with the long dimension perpendicular to the long dimension of the panel.

NOTE 2—Guidance on statistical sampling is provided in Practice **D2915**.

6. Moisture Content and Conditioning Requirements

6.1 The physical and mechanical properties of building panels depend on the moisture content at time of test.

6.2 The moisture conditioning selection for each test procedure within this standard depends upon the purpose of the particular tests under consideration. All specimens within each test sample shall be conditioned as required to meet the specific test objectives.

6.3 The following moisture conditioning regimens are commonly employed with the test procedures of this standard:

6.3.1 *Dry “As Received”*—Specimens to be tested “as received” shall be tested without supplemental conditioning to alter the moisture content.

6.3.2 *Dry “Conditioned”*—Specimens to be tested air-dry shall be conditioned to a constant weight and moisture content in a conditioning chamber maintained at a relative humidity of $65 \pm 5\%$ and a temperature of $68 \pm 6^\circ\text{F}$ ($20 \pm 3^\circ\text{C}$) (See **Note 3**).

NOTE 3—This conditioning regime represents a common standard for wood and wood-based materials.

6.3.3 *Water Soaked*—Specimens to be tested in the soaked condition shall be submerged in water at $68 \pm 2^\circ\text{F}$ ($20 \pm 1^\circ\text{C}$) for 24-h (see **Note 4**) before the test and shall be tested within 30 minutes upon removal from the water.

NOTE 4—When it is desired to obtain the effect of complete saturation, the specimens shall be soaked for a longer period.

6.3.4 *Accelerated Aging*—Accelerated aging cycles shall be completed per Section **7** of this standard.

6.3.5 *Other*—Other conditioning methods that are designed to meet the test objectives may be employed provided that they are clearly described in the test report.

6.4 Specimens shall be subjected to the conditioning regimens of section **6.3** after they have been cut to the final dimensional sizes required for the test procedures within this standard.

6.5 When water soaked conditioning (section **6.3.3**), accelerated aging conditioning (section **6.3.4**) or other conditioning method is employed to simulate an application moisture exposure:

6.5.1 The sample dimensions and weights shall be recorded before and after conditioning. Any computed properties shall be reported based upon both the pre-conditioned dimensions or weight, or both, and upon the dimensions or weight, or both, after the moisture conditioning treatment.

6.5.2 If the objective is to estimate the relative change in a property due to the moisture conditioning treatment, a matched set of material shall be tested in the dry (section **6.3.1** or **6.3.2**) condition. The conditioning treatment selected for the matched set shall be based upon the test objectives.

6.6 For all testing within this standard, the moisture conditioning method selected and resulting test sample moisture contents shall be reported.

7. Accelerated Aging

7.1 Scope and Significance

7.1.1 The accelerated aging treatment is one possible conditioning treatment (see Section **6**) and is used to obtain a measure of the inherent ability of a material to withstand severe exposure conditions and maintain its mechanical and physical properties. Appropriate specimens shall be prepared and subjected to the six cycles of accelerated aging before the property is evaluated. The cycling exposure is a simulated condition developed to evaluate how a material will stand up under aging conditions.

NOTE 5—All of the tests listed in this standard may not be required for any specific investigation or specification. Static bending (Section **9**), nail-holding (Sections **13 – 15**), and water absorption and thickness swelling (Section **23**) tests are usually sufficient to evaluate the resistance of a wood-base panel material to aging. In some instances it may be desirable to evaluate the effect of accelerated aging on some other property, including properties outside the scope of this standard.

7.2 Test Specimens

7.2.1 The test specimens shall be cut to size for testing and dimensions or weight measured, or both, as specified in the pertinent sections of this standard before being subjected to the cyclic exposure listed in section **7.3**. When tests involving fasteners are made, the fasteners shall be driven prior to the aging exposure. Corrosion-resistant fasteners shall be used because extractives or other materials present will corrode ordinary steel fasteners.

7.3 Accelerated Aging Cycles

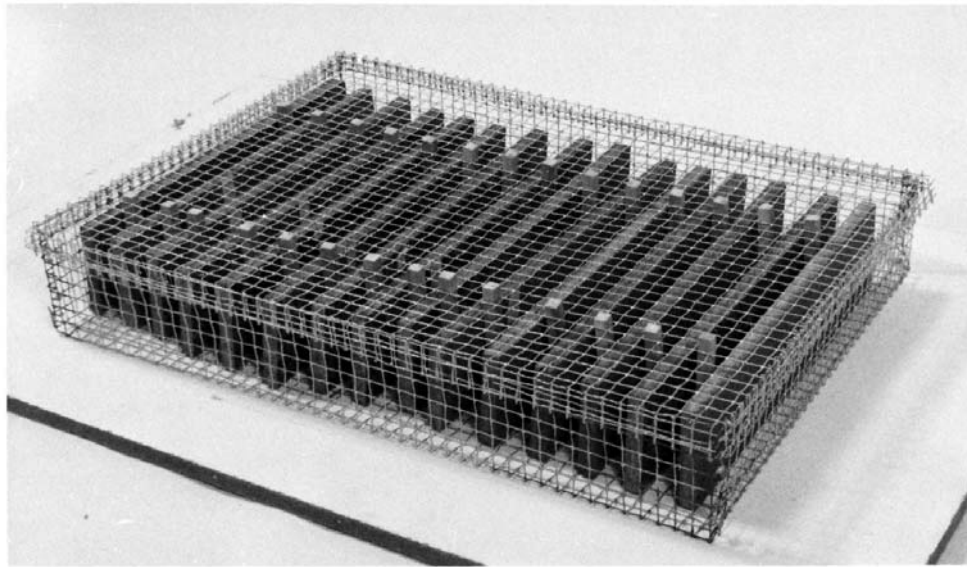

FIG. 1 Specimens Supported Vertically in Rack

7.3.1 Subject each specimen to six complete cycles of accelerated aging. If the cycle is to be broken, as for a weekend, the break shall be made during the freezing portion of the cycle. Each cycle shall consist of the following:

7.3.2 Immersion in water at $120 \pm 3^\circ\text{F}$ ($49 \pm 2^\circ\text{C}$) for 1 h,

7.3.3 Exposure to steam and water vapor at $200 \pm 5^\circ\text{F}$ ($93 \pm 3^\circ\text{C}$) for 3 h,

7.3.4 Freezing at $10 \pm 5^\circ\text{F}$ ($-12 \pm 3^\circ\text{C}$) for 20 h,

7.3.5 Heating at $210 \pm 3^\circ\text{F}$ ($99 \pm 2^\circ\text{C}$) in dry air for 3 h,

7.3.6 Exposure again to steam and water vapor at $200 \pm 5^\circ\text{F}$ ($93 \pm 3^\circ\text{C}$) for 3 h, and

7.3.7 Heating in dry air at $210 \pm 3^\circ\text{F}$ ($99 \pm 2^\circ\text{C}$) for 18 h.

7.3.8 After the completion of the six-cycle accelerated aging the specimens shall be conditioned at a temperature of $68 \pm 6^\circ\text{F}$ ($20 \pm 3^\circ\text{C}$) and a relative humidity of $65 \pm 2\%$ for at least 48 h before testing.

7.4 Handling and Support of Specimens During Exposure

7.4.1 The specimens shall be supported vertically in racks during accelerated aging. One example is shown in Fig. 1. Specimens shall fit in the racks loosely with at least 1-in. (25 mm) separation between specimens so as to freely permit swelling both parallel and perpendicular to the plane of the panel of the specimen. Racks shall not appreciably shield specimens nor prevent draining after soaking. Further, when in the tank during the exposure to steam and water vapor, specimens shall be placed so that jets of steam and vapor will not erode the specimens.

7.5 Apparatus

7.5.1 Tank and Controls for Soaking and Steaming:

7.5.1.1 *Tank or Vat*—A tank or vat, such as shown in Fig. 2, shall be used to conduct the exposures listed in 7.3.2, 7.3.3, and 7.3.6 of the accelerated aging test. A unit of the size shown is adequate for specimens of the size required in this standard. For tests of larger components, units as long as 9 ft (2.7 m) have proven to be satisfactory. The essential features of the tank are as follows:

7.5.1.2 Corrosion-resistant container, because of extractives developed during these cycles and present in wood-base materials,

7.5.1.3 A pipe to the bottom with a diffuser (perforated T-pipe),

7.5.1.4 A drain, although for larger tanks a pump has proven to be advantageous, and

7.5.1.5 A loose-fitting cover that will permit some steam to escape during steam and water vapor phase.

7.5.1.6 Supports shall be provided in the bottom of the tank to keep the specimens from direct contact with the water.

7.5.1.7 The tank may be insulated or uninsulated; but if insulated, the cover is to be left open during the steaming portion of the cycle. Heat loss during the soaking exposure (7.3.2) requires addition of heat by steam or the equivalent. This provides for circulation around the specimens being soaked and aids in maintaining the desired temperature with greater uniformity. Heat loss during the exposure to steam and water vapor (7.3.3 and 7.3.6) along with the escaping steam aids in providing a dynamic condition. During those steps the drain should be open to permit condensate to drain; or as an alternative method, the water level in the tank should be about 2 in. (51 mm) above the perforated pipes so that the steam percolates through it.

7.5.2 *Controls and Source for Soaking and Steaming*—A suitable unit for providing heat for soaking and exposure to steam and water vapor is shown diagrammatically in Fig. 3. In this instance, an air-operated dry kiln controller provides the temperature control required for either the soaking exposure (7.3.2) or the exposure to steam and water vapor (7.3.3 and 7.3.6). In operation for the soaking exposure (7.3.2) the tank is filled to the desired level by opening valves 1 and 3, after which valve 3 is closed. The controller is set at 120°F (49°C) and the sensor is placed in the water at mid-depth. Valve 2 is opened and steam flows into the water until desired temperature is attained and air-operated valve closes. Temperature is

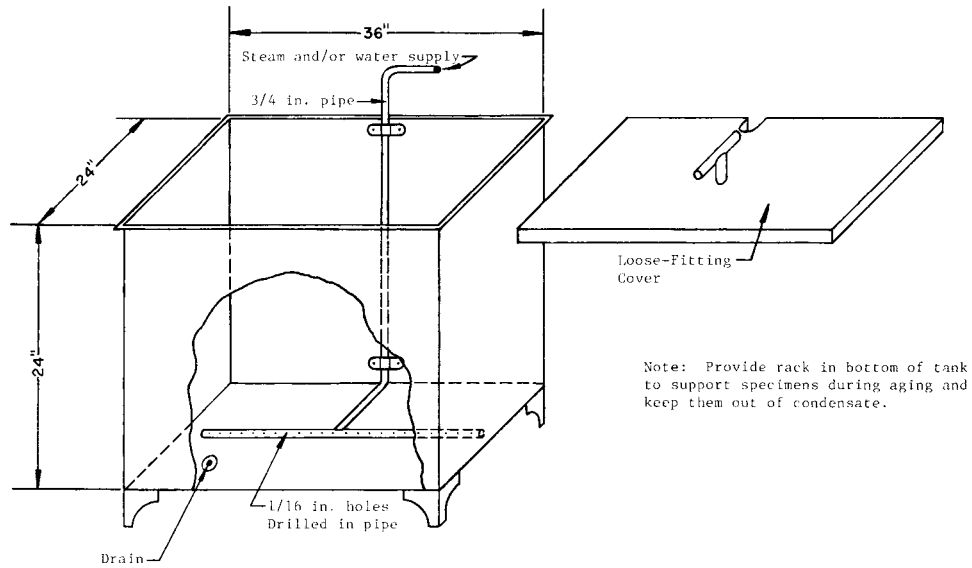

FIG. 2 Sketch of Stainless Steel Tank for Accelerated Aging Small Specimens

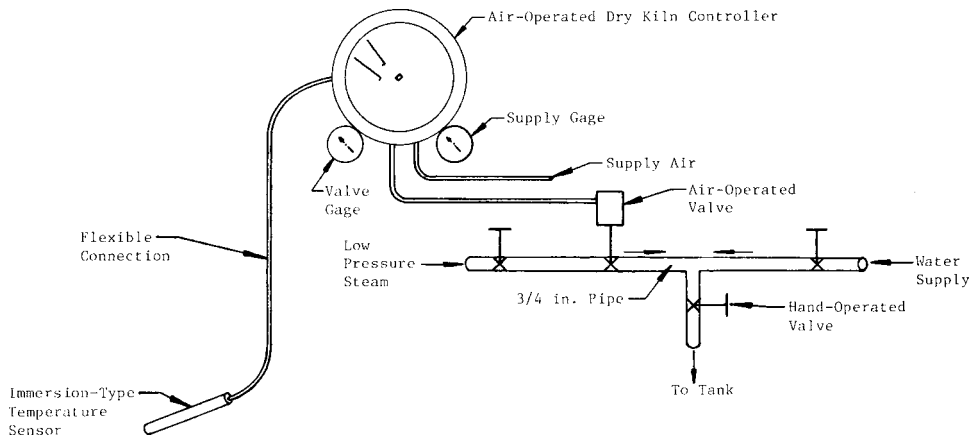

FIG. 3 Diagram of Air-Operated Controller for 120°F (49°C) Soaking and 200°F (93°C) Spraying

maintained automatically by addition of steam as required. For the exposures of 7.3.3 and 7.3.6, the controller is set for 200°F (93°C) so steam is automatically metered to maintain that temperature. Valve 2 is adjusted so that cycles of steam “on” are long with respect to steam “off.” This system requires a supply of compressed air.

7.5.2.1 An electrically controlled valve using thermistor-actuated relays will function as well. When steam is not readily available, a small boiler can be used as a source. This positive system of operation and control has proven to be satisfactory and requires a minimum of manpower time.

7.5.3 *Oven*—The oven for heating the specimens at 210°F (99°C) shall be of the positive ventilating type of sufficient capacity to maintain the desired temperature and remove moisture as fast as it is evaporated.

7.6 *Inspection of Material During Cyclic Exposure*

7.6.1 The test specimens shall be frequently inspected during the accelerated aging exposure for any signs of delamination or other disintegration. If there is any apparent damage to the material, it shall be described in the report, as well as the cycle exposure in which the damage became apparent.

7.7 *Testing and Reporting*

7.7.1 Tests for the appropriate properties shall be conducted after the final conditioning period (7.3.8). Calculations and reported results shall be based on both the original dimensions or weight, or both, and the dimensions or weight, or both, after the accelerated aging treatment.

8. **Size, Physical Properties and Appearance of Panels**

8.1 *Size of Finished Panels*

8.1.1 When measurements of finished panels are required, the width and length of each finished panel shall be obtained by measuring the width and length at each end and at mid-length to an accuracy of ±0.3 % or 1/16 in. (2 mm), whichever is smaller.

8.2 *Variation in Thickness*

8.2.1 For the determination of variations in thickness, specimens at least 6-in. (152-mm) square shall be used. The thickness of each specimen shall be measured at five points, near each corner and near the center, and the average thickness and the variation in thickness noted. These measurements shall be made to an accuracy of 0.001 in. (0.025 mm).

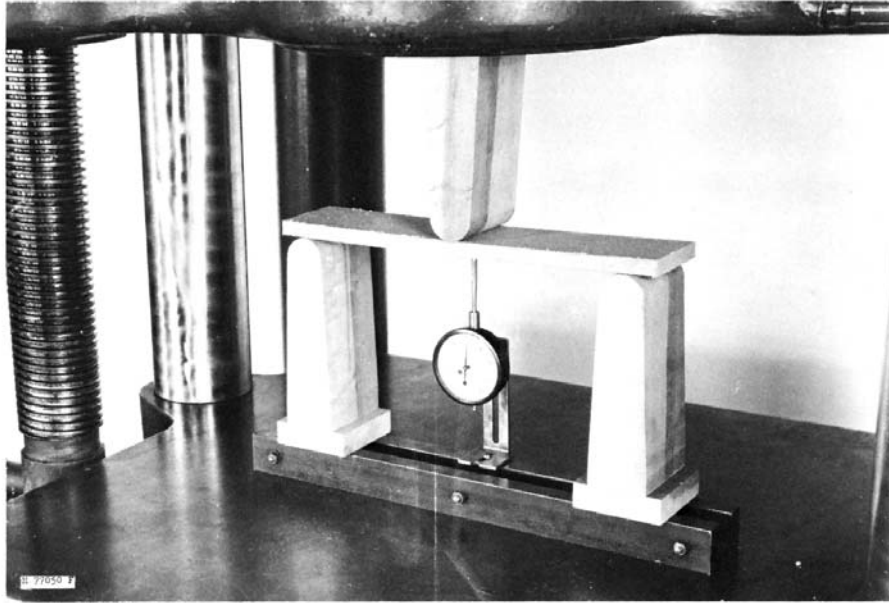

FIG. 4 Static Bending Test Assembly

8.3 Specific Gravity

8.3.1 When specific gravity of the finished panel is required, specific gravity shall be tested in accordance with Test Methods [D2395](#) Method A from a panel specimen with a minimum surface area of 9 in.² (58 cm²).

8.4 Moisture Content

8.4.1 The moisture content shall be measured in accordance with Test Methods [D4442](#) Method B from a panel specimen with a minimum surface area of 9 in.² (58 cm²). See [Note 6](#).

NOTE 6—The moisture content may be determined based upon the “as-tested” and “oven-dry” mass of specimens tested using one of the test procedures listed within this standard.

8.5 Surface Finish

8.5.1 The finish of both surfaces shall be described. A photograph of each surface may be taken to show the texture of the panel. This photograph shall show suitable numbering so that the building panel may be properly identified.

9. Static Bending

9.1 Scope

9.1.1 Static bending tests shall be made to determine the flexural properties, such as modulus of rupture and apparent modulus of elasticity. When required, the stress at proportional limit and work-to-maximum load can be determined. To evaluate directional properties, an equal number of specimens shall be tested with their long-axis parallel and perpendicular to the long-axis of the panel.

9.2 Test Specimen

9.2.1 Each test specimen shall be $3 \pm \frac{1}{32}$ in. (76 ± 1 mm) in width if the nominal thickness is greater than $\frac{1}{4}$ in. (6 mm), and $2 \pm \frac{1}{32}$ in. (51 ± 1 mm) in width if the nominal thickness is $\frac{1}{4}$ in. or less (see [Note 7](#)). The length of each specimen shall be 2 in. (51 mm) plus 24 times the nominal thickness (see [Notes 8 and 9](#)). The width and length, of each specimen shall

be measured to an accuracy of $\pm 0.3\%$. The thickness of each specimen shall be measured to an accuracy of 0.001 in. (0.025 mm).

NOTE 7—Based on industry practice, OSB is typically tested with a width of 4.5 in. (114 mm) in accordance with Test Methods [D3043](#) Method D.

NOTE 8—In cutting specimens to meet the length requirements of 2 in. (51 mm) plus 24 times the nominal thickness, it is not intended that the length be changed for small variations in thickness. Rather it is the thought that the nominal thickness of the panel under test should be used for determining the specimen length.

NOTE 9—Long-span specimens are desired for tests in bending so that the effects of deflections due to shear deformations will be minimized and the values of moduli of elasticity obtained from the bending tests will approximate the true moduli of the materials.

9.3 Span and Supports

9.3.1 The span for each test shall be 24 times the nominal thickness (depth) of the specimen (see [Note 10](#)), measured to an accuracy of $\pm \frac{1}{16}$ in. (2 mm). The supports shall be such that no appreciable crushing of the specimen will occur at these points during the test. The supports either shall be rounded or shall be bearing plates that are permitted to tilt and roll as the specimen deflects. When rounded supports, such as those shown in [Fig. 4](#), are used, the radius of the rounded portion shall be at least $\frac{1}{2}$ times the thickness of the material being tested. If the material under test deviates from a plane, laterally adjustable supports shall be provided (see [Note 11](#)).

NOTE 10—Establishment of a span-depth ratio is required to allow an accurate comparison of test values for materials of different thicknesses. It should be noted that the span is based on the nominal thickness of the material and it is not intended that the spans be changed for small variations in thickness.

NOTE 11—Laterally adjustable supports may be necessary for the specimens tested in the soaked condition because of warping or twisting that may occur due to soaking. Details of laterally adjustable supports may be found in Fig. 1 of Test Methods [D3043](#).

9.4 Procedure

9.4.1 The specimens shall be loaded at the center of span with the load applied to the top surface of the specimen, as the product will be installed. If the product can be installed in either direction then equal number of specimens shall be tested face-up and face-down. Testing shall maintain a uniform loading rate through a rounded loading block as shown in Fig. 4. The bearing blocks shall be at least 3 in. (76 mm) in width. The radius of the rounded portion of the loading block shall be approximately equal to 1½ times the thickness of the specimen.

9.4.2 For each specimen, the character and the sequence of the failure shall be noted, whether or not the initial failure was in compression or tension. See Note 12.

NOTE 12—Photographs of typical failures will be helpful.

9.5 Speed of Testing

9.5.1 The load shall be applied continuously throughout the test at a uniform rate of motion of the movable crosshead of the testing machine to achieve an outer fiber strain rate of 0.005 in./in./min (0.005 mm/mm/min) calculated in accordance with Eq 1. See Notes 13-15. The crosshead speed, adjusted for thickness, shall not vary by more than ±50 % from that specified for a given test. The speed of testing shall be recorded on the data sheet.

$$N = \frac{zL^2}{6d} \quad (1)$$

where:

- N = rate of motion of moving head, in./min (mm/min),
- z = outer fiber strain rate, in./in./min (mm/mm/min),
- L = span, in. (mm), and
- d = depth (thickness) of specimen, in. (mm).

NOTE 13—The crosshead speed shall mean the free-running, or no-load, crosshead speed for testing machines of the mechanical-drive type, and the loaded crosshead speed for testing machines of the hydraulic-loading type.

NOTE 14—Based on Eq 1, the calculated rate of head descent is:

- 0.12 in./min (3 mm/min) for ¼ in. (6 mm) thickness,
- 0.24 in./min (6 mm/min) for ½ in. (12 mm) thickness,
- 0.36 in./min (9 mm/min) for ¾ in. (19 mm) thickness,
- 0.48 in./min (12 mm/min) for 1 in. (25 mm) thickness.

NOTE 15—If a faster test speed is desired for Quality Assurance purposes, the principles of section 8.5 of Test Methods D3043 should be followed.

9.6 Load-Deflection Measurements

9.6.1 The load-deflection data shall be obtained until the maximum load is achieved. The deflection of the specimen shall be measured at the mid-span point by means of an indicating dial gage or linear voltage differential transducer (LVDT) or linear potentiometer (see Note 16) attached to the base of the testing jig, with the dial plunger in contact with the bottom of the specimen at the center. This arrangement is shown in Fig. 4. Note the load and deflection at first failure and at maximum load. Take readings of deflection at least to the nearest 0.005 in. (0.10 mm). Fig. 5 shows a typical load-deflection curve.

NOTE 16—The range of standard 0.001-in. (0.02-mm) indicating dial is 1 in. (25 mm). The total deflection of some thicknesses of panels may exceed 1 in. at failure. When this happens, either a 2-in. (50-mm) total-travel indicating dial or a suitable 2:1 reducing lever in conjunction

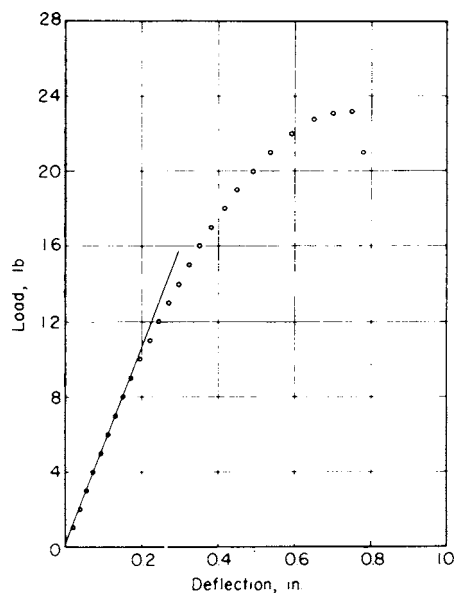

Metric Equivalents							
in.	0.2	0.4	0.6	0.8	1.0		
mm	5	10	15	20	25		
lb	4	8	12	20	24	28	
kg	1.8	3.6	5.4	7.2	9	10.8	12.6

FIG. 5 Typical Load-Deflection Curve for Static Bending Test

with a 1-in. travel dial should be used so that maximum deflections can be obtained.

9.7 Calculation and Report

9.7.1 The modulus of rupture, apparent modulus of elasticity, and when required, stress at proportional limit and work-to-maximum load shall be calculated for each specimen in accordance with the following equations:

$$R_b = \frac{3P_{max}L}{2bd^2} \quad (2)$$

$$E = \frac{L^3}{4bd^3} \frac{\Delta P}{\Delta y} \quad (3)$$

$$S_{pl} = \frac{3P_{pl}L}{2bd^2} \quad (4)$$

$$W_{ml} = \frac{a}{bdL} \quad (5)$$

where:

- a = area under load-deflection curve to maximum load, lbf.in. (N·m),
- b = width of specimen measured in dry condition, in. (mm),
- d = thickness (depth) of specimen measured in dry condition, in. (mm),
- E = apparent modulus of elasticity, psi (kPa),
- L = length of span, in. (mm),
- $\frac{\Delta P}{\Delta y}$ = slope of the straight line portion of the load-deflection curve (see Note 17), lbf/in. (N/mm),
- P_{max} = maximum load, lbf (N),
- P_{pl} = load at proportional limit (see Note 18), lbf (N),
- R_b = modulus of rupture, psi (kPa),

S_{pl} = stress at proportional limit, psi (kPa), and
 W_{ml} = work to maximum load, lbf-in./in.³ (N-mm/mm³).

NOTE 17—A linear regression of the load-deflection curve between 10% and 40% of P_{max} generally produces satisfactory results for ($\Delta P/\Delta y$).

NOTE 18— P_{pl} can be determined at the point on the load-deflection curve where the slope of the tangent deviates from the slope of the straight line ($\Delta P/\Delta y$) more than a given threshold value. The threshold value can be established based on statistical and graphical methods and experience. The value of 10% normally gives a good estimate but it depends on the calculation procedure, the type and condition of product.

9.7.2 The report shall include the orientation of the face of the panel during the test (face-up or face down), the description of failure, and the calculated properties for each specimen. For modulus of elasticity and stress at proportional limit the parameters used in calculations shall be reported.

10. Tension Parallel to Surface

10.1 Scope

10.1.1 The tension test parallel to the surface shall be made to determine the tensile strength in the plane of the panel. When required, the axial stiffness or modulus of elasticity can be determined. To evaluate directional properties, an equal number of specimens shall be tested with their long-axis parallel and perpendicular to the long-axis of the panel. See Note 19.

NOTE 19—When the materials exceed 1 in. in thickness, crushing at the grips during test is likely to adversely affect the test values obtained. It is recommended that for material greater than 1 inch in thickness, the material be sawn to 1/2 in. (12 mm) thickness. Test values obtained from resawn specimens may be only approximate, because strengths of material near the surface may vary from the remainder.

10.2 Test Specimen

10.2.1 Each test specimen shall be prepared as shown in Fig. 6. The reduced section shall be cut to the size shown with a band saw. The minimum width of each specimen at the reduced section shall be measured to an accuracy of $\pm 0.3\%$. The corresponding thickness shall be measured to an accuracy of 0.001 in. (0.025 mm).

10.3 Procedure

10.3.1 The specimen shall be loaded using self-aligning, self-tightening grips that distribute the force evenly over the grip surface and do not allow slipping, with gripping surfaces at least 2-in. (50-mm) square, to transmit the load from the testing machine to the specimen. Fig. 7 shows a typical assembly for the tension test of building panels.

10.3.2 For each specimen, the character and location of the failure shall be noted.

10.4 Speed of Testing

10.4.1 The load shall be applied continuously throughout the test at a uniform rate of motion of the movable crosshead of the testing machine of 0.15 in./min (4 mm/min) $\pm 50\%$. See Note 13.

10.5 Load-Deformation Measurements

10.5.1 When required, obtain load-deformation curves. To measure the deformation, attach an extensometer or other suitable device over the central portion of the specimen. Points of attachment (gage points) shall be within the reduced section of the specimen. Read the deformation to the nearest 0.0001 in.

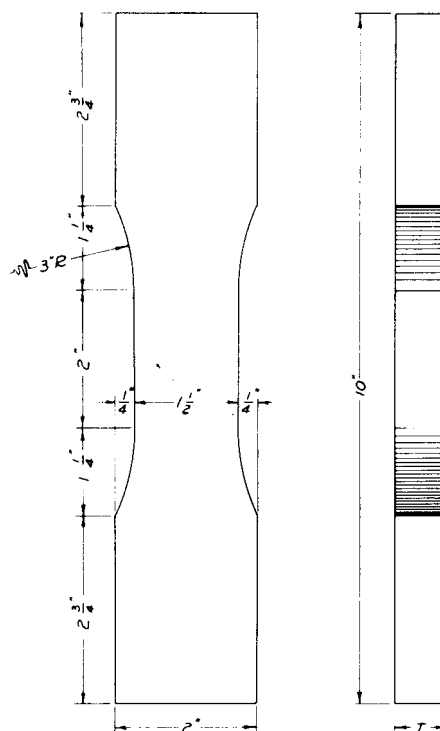

T = THICKNESS OF MATERIAL, BUT NOT TO EXCEED 1 INCH

Metric Equivalents								
in.	1/4	1	1 1/4	1 1/2	2	2 3/4	3	10
mm	6	25.4	32	38	51	70	76	254

FIG. 6 Detail of Specimen for Tension Test Parallel to Surface

(0.0025 mm). Choose increments of loading so that not less than 12 readings are obtained before proportional limit.

10.6 Calculation and Report

10.6.1 The maximum tensile stress and, when required, modulus of elasticity shall be calculated for each specimen in accordance with the following equations:

$$R_t = \frac{P_{max}}{bd} \quad (6)$$

$$E_t = \frac{l_g \Delta P}{bd \Delta y} \quad (7)$$

where:

- b = width of the reduced cross-section of the specimen measured in dry condition, in. (mm),
- d = thickness of the specimen measured in dry condition, in. (mm),
- E_t = modulus of elasticity in tension parallel to the surface of the panel, psi (MPa),
- l_g = gage length or distance between the gage points of extensometer, in. (mm),
- $\Delta P/\Delta y$ = slope of the straight line portion of the load-deformation curve (see Note 17), lbf/in. (N/mm),
- P_{max} = maximum load, lbf (N), and
- R_t = maximum tensile stress, psi (MPa).

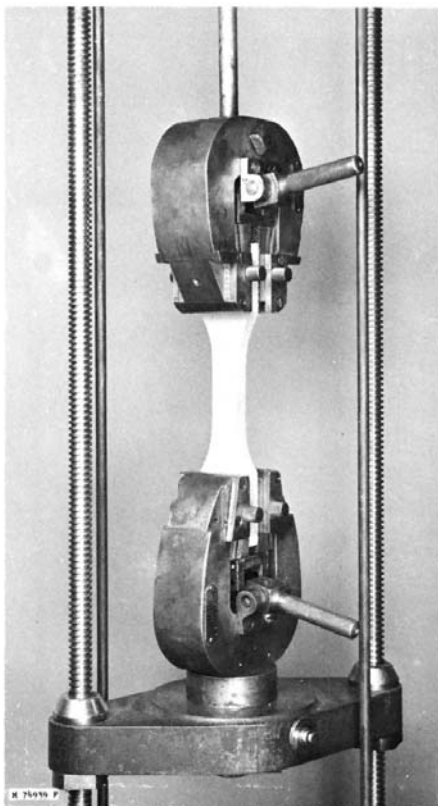

FIG. 7 Assembly for Tension Test Parallel to Surface

10.6.2 The report shall include the calculated properties and the description of failure for each specimen. If the failure is within ½ in. (12 mm) of either grip, the test value shall be discarded.

11. Tension Perpendicular to Surface (Internal Bond)

11.1 Scope

11.1.1 The tension test perpendicular to the surface shall be made to determine cohesion of the panel in the direction perpendicular to the plane of the panel.

11.2 Test Specimen

11.2.1 The test specimen shall be 2-in. (50-mm) square and the thickness shall be that of the finished panel. The dimensions of the specimen shall be measured to an accuracy of ±0.3 %.

11.3 Procedure

11.3.1 Loading blocks of steel or aluminum alloy 2-in. (50-mm) square and 1 in. (25 mm) in thickness shall be effectively bonded with a suitable adhesive (see Note 20) to the square faces of the specimen. The resulting bond shall exceed the cohesive strength of the material perpendicular to the plane of the panel. Fig. 8 shows details of the specimen and loading fixtures. The maximum distance from the center of the universal joint or self-aligning head to the glued surface of the specimen shall be 3 in. (76 mm).

NOTE 20—Any suitable adhesive that provides an adequate bond may be used for bonding the specimen to the loading blocks. Epoxy resins are recommended as a satisfactory bonding agent. Other resins such as hot

melt cements or water based adhesives may be used provided the conditions of gluing do not significantly alter the moisture condition of the specimen. The pressure required to bond the blocks to the specimen will depend on the density of the panel and the adhesive used, and should not damage the specimen.

11.3.2 Engage the loading fixtures, such as are shown in Fig. 8, attached to the heads of the testing machine, with the blocks attached to the specimen. Stress the specimen by separation of the heads of the testing machine until failure occurs. The direction of loading shall be as nearly perpendicular to the faces of the specimen as possible, and the center of load shall pass through the center of the specimen.

11.4 Speed of Testing

11.4.1 The load shall be applied continuously throughout the test at a uniform rate of motion of the movable crosshead of the testing machine 0.08 in./in. (cm/cm) of thickness per min. It is not intended that the testing machine speed shall be varied for small differences in panel thickness such as an embossed surface, but rather that it shall not vary more than ±50 % from that specified herein. See Note 13.

11.5 Calculation and Report

11.5.1 The internal bond of each specimen shall be calculated in accordance with the following equation:

$$IB = \frac{P_{max}}{ab} \quad (8)$$

where:

- a = width of the specimen measured in dry condition, in. (mm),
- b = length of the specimen measured in dry condition, in. (mm),
- P_{max} = maximum load, lbf (N), and
- IB = internal bond strength, psi (MPa).

11.5.2 The report shall include the location of the plane of failure such as the face/layer or the upper, middle or lower third. If any of the specimens fails due to failure of the adhesive bond to the loading block, the test result of that specimen shall be discarded.

12. Compression Parallel to Surface

12.1 Scope

12.1.1 The compression test parallel to the surface shall be made to determine the compressive strength in the plane of the panel. When required, the axial stiffness or modulus of elasticity and stress at proportional limit can be determined. To evaluate directional properties, an equal number of specimens shall be tested with their long-axis parallel and perpendicular to the long-axis of the panel.

12.2 Test Methods

12.2.1 Because of the large variation in character of wood-base fiber and particle panel materials and the differences in manufactured thicknesses, one method is not applicable for all materials. One of the three methods detailed as follows shall be used depending on the character and thickness of the panel being evaluated:

12.2.2 Method A (Laminated Specimen), shall be used for materials ¾ in. (10 mm) or more but less than 1 in. (25 mm) in nominal thickness, particularly when modulus of elasticity

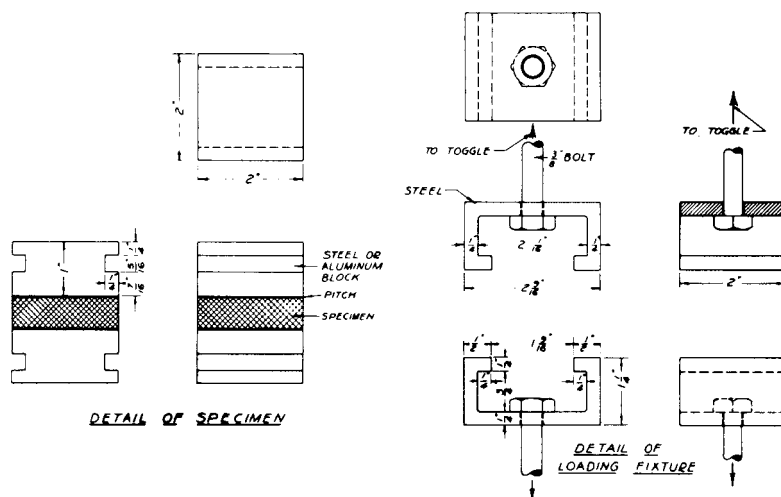

Metric Equivalents

in.	1/4	5/16	3/8	7/16	1/2	3/4	1 1/4	1 1/16	2	2 1/16	2 9/16
mm	6	7.5	9	10.5	12.7	19	31.7	39	51	52	64.3

FIG. 8 Detail of Specimen and Loading Fixture for Tension Test Perpendicular to Surface

and stress at proportional limit are required. Laminate two thicknesses when the material is 1/2 in. (13 mm) or greater thickness. Use three thicknesses for materials with thickness less than 1/2 in. (13 mm). The nominal size of the specimen shall be 1 by 4 in. (25 by 102 mm) by the thickness as laminated. The 4-in. (102-mm) long dimension shall be parallel to the applied force.

12.2.3 *Method B (Lateral Support)*, shall be used for materials less than 3/8 in. (10 mm) in thickness, particularly when modulus of elasticity and stress at proportional limit are required. Specimens shall be 1 by 4 in. (25 by 102 mm) by the thickness as manufactured and evaluations made in a suitable lateral support device. The 4-in. (102-mm) long dimension shall be parallel to the applied force.

12.2.4 *Method C (Short Column)*, shall be used when maximum crushing strength only is required or where the thickness of the panel material is 1 in. (25 mm) or more and either maximum crushing strength, modulus of elasticity, and stress at proportional limit or only maximum crushing strength is required. When the material being evaluated is 1 in. or less in thickness, the width of the specimen shall be 1 in. (25 mm), the thickness shall be as manufactured, and the length (height as tested) shall be four times the thickness. When the material being evaluated is more than 1 in. (25 mm) in thickness, the width shall be equal to the nominal thickness and the length (height as loaded) shall be four times the nominal thickness.

12.3 Test Specimen

12.3.1 The test specimens shall be carefully sawn with surfaces smooth and planes at right angles to the faces of the panels as manufactured. For the laminated specimens (Method A), pieces of panel at least 1 in. (25 mm) larger in length and width than the finished size of specimen shall be laminated using thin spreads of epoxy resin or other adhesive that does not contain water or other swelling agent (see Note 21). Bonding pressures shall not exceed 50 psi (345 kPa). Test

specimens shall be sawn from the laminated pieces after at least 8 h of curing of the resin at room temperature. The thickness shall be measured to at least the nearest 0.001 in. (0.025 mm). The width shall be measured to an accuracy of ±0.3 %.

NOTE 21—An adhesive that contains water or other swelling agent might produce internal stresses adjacent to the glue lines.

12.4 Method of Loading

12.4.1 The specimen shall be loaded through a spherical loading block, preferably of the suspended self-aligning type. The specimen shall be centered carefully in the testing machine in a vertical plane as shown in Fig. 9 for unsupported 4-in. (102-mm) specimen and in Fig. 10 for laterally supported pack device. See Note 22.

NOTE 22—The lateral support device is detailed in Fig. 2 of Test Methods D3501.

12.5 Speed of Testing

12.5.1 The load shall be applied continuously throughout the test at a uniform rate of motion of the movable crosshead of the testing machine of 0.005 in./in. (mm/mm) of length per min. Speed of test therefore for the 4-in. specimen of Methods A and B shall be 0.02 in./min (0.5 mm/min.). See Note 13. The crosshead speed shall not vary by more than ±50 % from that specified for a given test.

12.6 Load-Deformation Measurements

12.6.1 When required, obtain load-deformation curves for the full duration of each test. Fig. 9 shows a Lamb's Roller Compressometer on an unsupported specimen. Fig. 10 shows a Marten's Mirror Compressometer on a laterally supported specimen. Use these or equally accurate instruments for measuring deformation. Attach compressometer over the central portion of the length; points of attachment (gage points) shall be at least 1 in. (25 mm) from the ends of specimen.

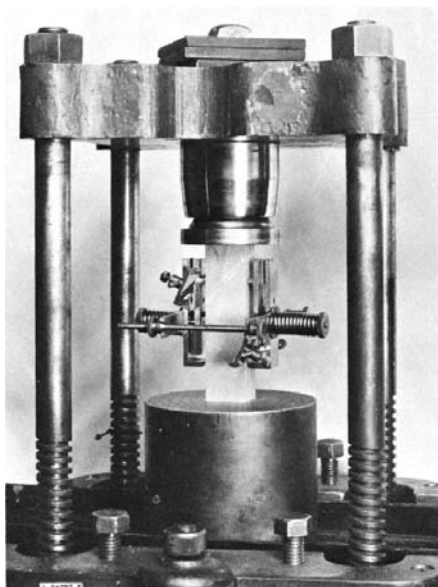

FIG. 9 Assembly for Compression Parallel to Surface Test of Un-supported Specimen

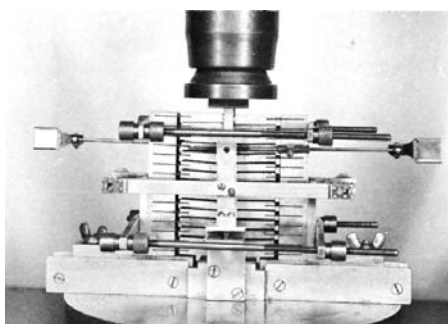

FIG. 10 Assembly for Compression Parallel to Surface Test of a Laterally Supported Specimen

Choose increments in loading so that not less than 12 readings are obtained before proportional limit. Read deformation to the nearest 0.0001 in. (0.0025 mm).

12.7 Calculation and Report

12.7.1 The compressive strength and, when required, modulus of elasticity and stress at proportional limit shall be calculated in accordance with the following equations:

$$R_c = \frac{P_{max}}{bd} \quad (9)$$

$$E = \frac{l_g}{bd} \frac{\Delta P}{\Delta y} \quad (10)$$

$$S_{pl} = \frac{P_{pl}}{bd} \quad (11)$$

where:

- b = width of specimen measured in dry condition, in. (mm),
- d = thickness of specimen measured in dry condition, in. (mm),
- E_t = modulus of elasticity in tension parallel to the surface of the panel, psi (MPa),

- l_g = distance between the gage points of compressometer, in. (mm),
- $\Delta P/\Delta y$ = slope of the straight line portion of the load-deformation curve (see Note 17), lbf/in. (N/mm),
- P_{max} = maximum load, lbf (N),
- P_{pl} = load at proportional limit (see Note 18), lbf (N),
- R_c = compressive strength, psi (MPa), and
- S_{pl} = stress at proportional limit, psi (MPa).

12.7.2 The report shall indicate which method (laminated specimen, lateral support, or short column) was used and the calculated properties for each specimen. The type of failure of each specimen shall be determined and included in the report.

13. Lateral Nail Resistance

13.1 Scope

13.1.1 Nail-holding tests shall be made to measure the panel's resistance to lateral movement of a nail through a panel (Note 23). To evaluate directional properties, an equal number of specimens shall be tested with the movement of the nail parallel and perpendicular to the long-axis of the panel.

NOTE 23—If this test is performed on some panels, the nail may bend and pull out of the stirrup. If this happens, the maximum load does not characterize the true resistance of the panel and this result should be noted. In these situations, the nail may be replaced with a hardened steel dowel of an equivalent diameter to avoid nail bending and determine the true resistance of the panel.

NOTE 24—Values obtained from this test are dependent on the thickness of the specimen. Values, however, are not directly proportional to the thickness. For this reason values obtained from tests of different panels can only be compared exactly if the thicknesses are equal.

13.2 Test Specimen

13.2.1 The test specimen shall be 3 in. (76 mm) in width and of convenient length with the thickness of the panel as manufactured. The test fastener (see Note 25) shall be driven at the right angle to the face of the panel so that about an equal length of nail projects from each face. The fastener shall be centered on the width and located $\frac{1}{4}$, $\frac{3}{8}$, $\frac{1}{2}$, or $\frac{3}{4}$ in. (6, 10, 13, or 19 mm) from one end (see Note 26). Tests shall be made for all four edge distances for each material tested. The thickness of each specimen shall be measured to an accuracy of $\pm 0.3\%$.

NOTE 25—A smooth shank six penny (6d) common wire nail with a 0.113 in. (2.90 mm) diameter shank is commonly used for this test. Other fasteners, including hardened steel dowels of equivalent diameter may be selected to meet the test objectives. It is advisable to measure the variation in diameter of the fastener.

NOTE 26—The edge distance is the distance from the center of the fastener to the edge of the panel.

13.3 Specimens Tested in the Dry Condition

13.3.1 When the tests are conducted with dry “as received” (section 6.3.1) or dry “conditioned” (section 6.3.2) materials, the tests shall be made immediately after the fasteners have been driven.

13.4 Specimens Moisture Cycled Before Test

13.4.1 When a water soaked (section 6.3.3), accelerated aging (section 6.3.4) or other conditioning method is employed to simulate an application moisture exposure with this test method, the fastener shall be driven prior to the moisture cycle.

13.5 Method of Loading

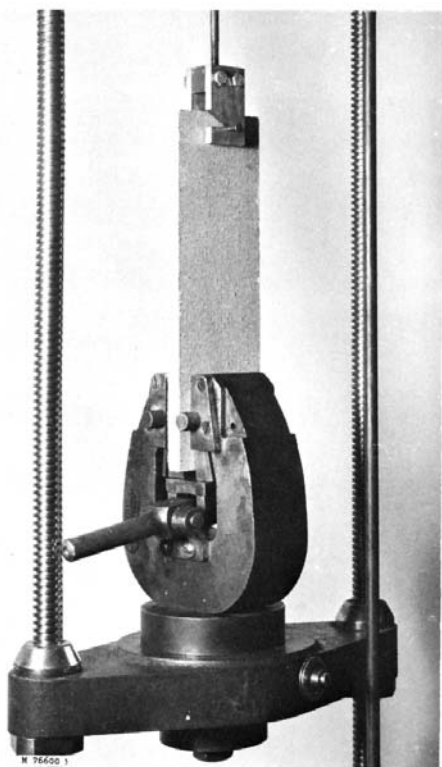

FIG. 11 Test Assembly for Measuring the Resistance of Nails to Lateral Movement

13.5.1 Clamp the end of the specimen opposite to the end with the test fastener in a position parallel to the movement of the testing machine. A grip such as the type used for tension tests parallel to the plane of the panel is suitable. Engage the fastener by the stirrup, and connect in turn to one platen of the testing machine by a rod. A typical test assembly for measuring the resistance of a nail in the lateral direction is shown in Fig. 11. The stirrup and connections are detailed in Fig. 12. See Note 27.

NOTE 27—For other types of fasteners, such as staples, modification of the stirrup may be necessary.

13.6 Speed of Testing

13.6.1 The specimen shall be loaded continuously throughout the test by separation of the heads of the testing machine at a uniform rate of crosshead speed of 0.25 in./min (6 mm/min) $\pm 50\%$. See Note 13.

13.7 Test Data and Report

13.7.1 The load required to move the fastener to the edge of the specimen shall be the measure of the lateral resistance. The maximum load and the nature of failure shall be included in the report. See Note 28. The type and diameter of fastener used shall be described in the report.

NOTE 28—In some cases it is useful to report the resistance in lbf/in. (N/mm) dividing the maximum load by the depth of fastener penetration; for example, when different panel thicknesses are compared.

14. Nail Withdrawal

14.1 Scope

14.1.1 Nail-holding tests shall be made on nails driven through the specimen from face to face to measure the resistance to the nail withdrawal in a direction normal to the face of the panel.

14.2 Test Specimen

14.2.1 The test specimen shall be of convenient size, at least 3 by 6 in. (76 by 152 mm) in plane, and the thickness of the panel as manufactured. The test fastener shall be driven through the panel at the right angle to the face, and at least $\frac{1}{2}$ in. (13 mm) of the shank portion shall project above the surface of the panel. The thickness of each specimen shall be measured to an accuracy of $\pm 0.3\%$. See Notes 29 and 30.

NOTE 29—A smooth shank six penny (6d) common wire nail with a 0.113 in. (2.90 mm) diameter shank is commonly used for this test. It is advisable to measure the variation in diameter of the nails. In certain instances it may be more desirable to use a pointed steel pin with a head or other suitable end to engage the load-applying fixture.

NOTE 30—Where the use of a particular nail or fastener requires less than $\frac{1}{2}$ in. of shank projecting above the surface, then only sufficient length may be left to permit engagement in the testing assembly.

14.3 Specimens Tested in the Dry Condition

14.3.1 When the tests are conducted with dry “as received” (section 6.3.1) or dry “conditioned” (section 6.3.2) materials, the withdrawals shall be made immediately after the fasteners have been driven.

14.4 Specimens Moisture Cycled Before Test

14.4.1 When a water soaked (section 6.3.3), accelerated aging (section 6.3.4) or other conditioning method is employed to simulate an application of moisture exposure with this test method, the fastener shall be driven prior to the moisture cycle.

14.5 Method of Loading

14.5.1 The assembly for the nail direct-withdrawal test is shown in Fig. 13. Attach the specimen-holding fixture to the lower platen of the testing machine. Insert the specimen in the fixture with the heads of the nails up, as shown. Engage the heads of the nails by the load-applying fixture equipped with a slot for easy attachment. This loading fixture shall be attached to the upper platen of the testing machine. Loads shall be applied by separation of the platens of the testing machine. The fitting is detailed in Fig. 14. See Note 31.

NOTE 31—For other types of fasteners, such as staples, modification of the loading fixture may be necessary.

14.6 Speed of Testing

14.6.1 The specimen shall be loaded continuously throughout the test by a uniform motion of the movable head of the testing machine at a rate of 0.06 in./min (1.5 mm/min) $\pm 50\%$. See Note 13.

14.7 Test Data and Report

14.7.1 The maximum load required to withdraw the fastener shall be the measure of resistance of the material to direct fastener withdrawal, and shall be included in the report. See Note 28. The type and the size of the fastener used shall be described in the report.

15. Nail-Head Pull-Through

15.1 Scope

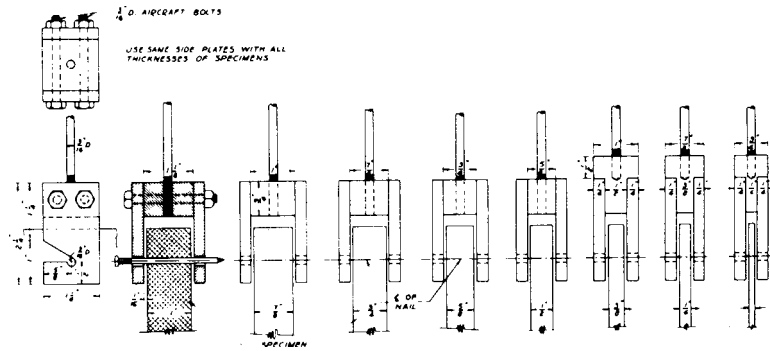

Metric Equivalents

in.	1/16	1/8	3/16	3/8	1/2	5/8	3/4	7/8	1	1 1/8	1 1/4	2 1/4
mm	1.5	3	4.5	9	12.7	15	19	21	25.4	28	32	57

FIG. 12 Detail of Stirrups and Connections for Measuring the Resistance of Nails to Lateral Movement

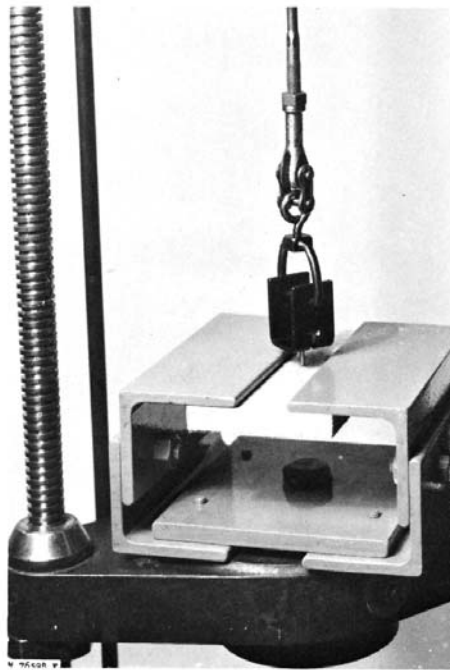

FIG. 13 Test Assembly for Measuring the Resistance of Nails to Direct Withdrawal

15.1.1 Nail-head pull-through tests shall be made to measure the resistance of a panel to having the head of a common nail or other fastener pulled through the panel. This test is to simulate the condition encountered with forces that tend to pull paneling or sheathing from a frame. See Note 24 and Note 32.

NOTE 32—For interior applications, the resistance to pull-through of a finishing nail may be preferred. For other applications, some special fasteners like staples or roofing nails may be desired instead of a common nail.

15.2 Test Specimen

15.2.1 The test specimen shall be of convenient size, at least 3 by 6 in. (76 by 152 mm) in plane, and the thickness of the panel as manufactured. The test nail shall be driven through the panel at the right angle to the face with the head flush with the

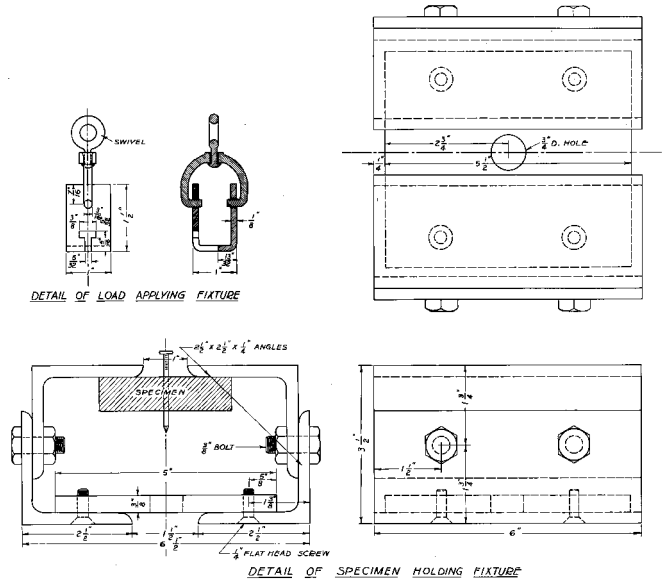

NOTE 1—1 in. = 25.4 mm.

FIG. 14 Details of Testing Equipment for Measuring the Resistance of Nails to Direct Withdrawal

surface of the panel (see Note 33). The size of the head and shank diameters of the nails used for this testing shall be measured and reported to an accuracy of ±1.0%. The thickness of each specimen shall be measured to an accuracy of ±0.3%.

NOTE 33—A sixpenny (6d) common wire nail with a 0.266 in. (6.75 mm) diameter head and a 0.113 in. (2.90 mm) diameter shank is commonly used for this test. Other fasteners may be selected to meet the test objectives.

15.3 Specimens Tested in the Dry Conditions

15.3.1 When the tests are conducted with dry “as received” (section 6.3.1) or dry “conditioned” (section 6.3.2) materials, the pull through shall be made immediately after the fasteners have been driven.

15.4 Specimens Moisture Cycled Before Test

15.4.1 When a water soaked (section 6.3.3), accelerated aging (section 6.3.4) or other conditioning method is employed to simulate an application of moisture exposure with this test method, the fastener shall be driven prior to the moisture cycle.

15.5 Method of Loading

15.5.1 Modify the assembly for the direct withdrawal test detailed in Fig. 14 by replacing the top pair of angles in the specimen-holding fixture with a 6-in. (152-mm) length of 6 by 2¼-in. (152 by 57-mm) steel channel. The web of the channel shall have a 3-in. (76-mm) diameter opening centered in the web. The edge of this opening provides the support to the specimen during test. The specimen-holding fixture shall be centered and attached it to the lower platen of the testing machine. The specimen shall be inserted in the holding fixture with the point of the test fastener up. The pointed end of the fastener shall be gripped with a gripping device of such a design as to allow accurate specimen positioning and true axial loading (see Note 34). Load shall be applied by separation of the platens of the testing machine.

NOTE 34—A “Jacob’s”-type drill chuck attached to the upper platen of the testing machine with a universal joint or toggle linkage, to provide for automatic aligning, has been used successfully.

15.6 Speed of Testing

15.6.1 The specimen shall be loaded continuously throughout the test by a uniform motion of the movable head of the testing machine at a rate of 0.06 in./min (1.5 mm/min) \pm 50 %. See Note 13.

15.7 Test Data and Report

15.7.1 The maximum load required to pull the head of the fastener through the panel shall be the measure of resistance of the material to fastener-head pull-through, and shall be included in the report for each specimen. See Note 28. The report shall describe the type and head and shank diameters of the nails used and the failure modes observed.

16. Direct Screw Withdrawal

16.1 Scope

16.1.1 Screw-holding tests shall be made on screws threaded into the panel to measure the resistance to screw withdrawal in a plane normal to the face of the panel. For numerous applications, the withdrawal resistance of screws from the edge of the panel is desired. When that value is required the screw withdrawal resistance in the plane parallel to the face shall be determined. See Note 24.

16.2 Test Specimen

16.2.1 *Withdrawal from the Face of the Panel*—The test specimen shall be of convenient size, at least 3 by 4 in. (76 by 102 mm) in plane. The thickness of the specimen shall be at least 1 in. (25 mm) unless other considerations make it desirable to test with the thickness as manufactured, because local bending of the panel at withdrawal may affect test results. If necessary, glue up two or more thicknesses of the panel to arrive at the 1-in. minimum thickness. A rubber cement or other suitable flexible adhesive shall be used, which does not alter the properties and moisture condition of the panel. The screw (see Note 35) shall be threaded ⅔ in. (17 mm) into a lead hole in the specimen at the right angle to the face of the panel. The

lead hole shall be predrilled using a drill of 0.9 of the root diameter of the screw (see Note 36).

16.2.2 *Withdrawal from the Edge of the Panel*—The test specimen shall be of convenient size, at least 3 by 6 in. (76 by 152 mm) in plane, and the thickness of the panel as manufactured (see Note 37). To evaluate directional properties, an equal number of specimens shall be tested with screw withdrawal parallel and perpendicular to the long-axis of the panel. The screw (see Note 35) shall be threaded ⅔ in. (17 mm) into a lead hole in the edge of the panel at midthickness at the right angle to the surface of the edge. The lead hole shall be predrilled using a drill of 0.9 of the root diameter of the screw (see Note 36).

NOTE 35—Number 10 Type AB screws should have a root diameter 0.138 ± 0.003 in. (3.51 ± 0.1 mm) and a pitch of 16 threads per inch. The diameter of the lead hole should be 0.125 in. (3.2 mm).

NOTE 36—It is recognized that some other lead hole diameter may give higher withdrawal resistance values for some densities and kinds of panels. Departures from this size of lead hole are permitted, but diameter used shall be reported.

NOTE 37—In some applications where several thicknesses of hardboard or the thinner particleboard are laminated together, it may be desirable to obtain the edge withdrawal resistance of a laminated panel. When this is done, the specimen is laminated from an odd number of thicknesses and the screw is located at the midthickness of the center laminate.

16.3 Specimens Tested in the Dry Condition

16.3.1 When the tests are conducted with dry “as received” (section 6.3.1) or dry “conditioned” (section 6.3.2) materials, the withdrawals shall be made immediately after the screws have been embedded.

16.4 Specimens Cycled Before Test

16.4.1 When a water soaked (section 6.3.3), accelerated aging (section 6.3.4) or other conditioning method is employed to simulate an application of moisture exposure with this test method, the screw shall be embedded prior to the moisture cycle.

16.5 Method of Loading

16.5.1 The assembly for the direct screw withdrawal is the same as shown for direct nail withdrawal in Fig. 13. Attach the specimen-holding fixture to the lower platen of the test machine. Insert the specimen in the fixture with the head of the screw up as shown. Engage the head of the screw by the load-applying fixture equipped with a slot for easy attachment. Attach this loading fixture to the upper platen of the testing machine. Load shall be applied by separation of the platens of the testing machine.

16.6 Speed of Testing

16.6.1 The specimen shall be loaded continuously throughout the test by a uniform motion of the movable head of the testing machine at a rate of 0.06 in./min (1.5 mm/min) \pm 50 %. See Note 13.

16.7 Test Data and Report

16.7.1 The report shall include the following:

16.7.2 Type of withdrawal resistance (face, edge-parallel or edge-perpendicular to the long axis of the panel) and the maximum load required to withdraw the screw from the panel. See Note 28). If the screw is broken rather than withdrawn, it shall be noted and the test value shall be discarded.

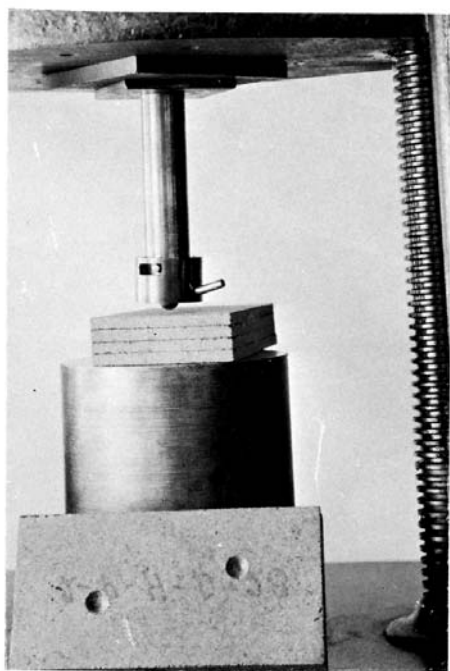

FIG. 15 Janka Ball Test Apparatus for Hardness of Panels

16.7.3 The type and size of the screw, and diameter of lead hole actually used.

16.7.4 Thickness of the panel and depth of screw penetration as actually tested.

17. Hardness

17.1 Scope

17.1.1 The modified Janka-ball test method shall be used for determining hardness of panel.

17.2 Test Specimen

17.2.1 Each specimen shall be nominally 3 by 6 in. (76 by 152 mm) in plane and at least 1 in. (25 mm) thick (see Note 38). Because most panels are manufactured in thicknesses of less than 1 in. (25 mm), the specimen for test shall be made by bonding together several layers of the panels to make the required thickness. A rubber cement or other suitable flexible adhesive shall be used, which does not alter the properties and moisture condition of the panel. The finished specimen shall be trimmed after bonding so that edges are smooth. The thickness of the specimens as tested shall be measured to an accuracy of $\pm 0.3\%$.

NOTE 38—If the purpose of the test is to measure the indentation resistance of the panel as manufactured, the multiple piece specimen may be tested without gluing the layers together.

17.3 Procedure

17.3.1 The modified Janka-ball test method shall be used with a “ball” 0.444 in. (11.3 mm) in diameter. The load shall be recorded when the “ball” has penetrated to one-half its diameter into the panel, as determined by an electric circuit indicator or by the tightening of the collar against the specimen. The test assembly with a tool of the tightening collar type is shown in Fig. 15.

17.3.2 Two penetrations shall be made on each of the two flat faces of the panel. The locations of the points of penetration shall be at least 1 in. (25 mm) from the edges and ends of the specimen and far enough apart so that one penetration will not affect another one.

17.4 Speed of Testing

17.4.1 The load shall be applied continuously throughout the test at a uniform rate of motion of the movable crosshead of the testing machine of 0.25 in./min (6 mm/min) $\pm 50\%$. See Note 13.

17.5 Test Data and Report

17.5.1 The load required to embed the “ball” to one-half its diameter into the panel shall be the measure of hardness, and shall be included in the report. Where one face of the panel is different from the other, as for example the smooth face and wire-textured back of most hardboards, the data obtained from the two faces shall be reported separately. The thickness of the test material shall also be included.

18. Hardness Modulus

18.1 Scope

18.1.1 The hardness modulus method of determining “equivalent Janka-ball hardness” may be used for determining hardness of building fiberboard and particleboard panels

18.2 Significance and Use

18.2.1 The hardness modulus (in pounds per inch of penetration) divided by 5.4 gives the equivalent Janka-ball hardness in pounds.³ The thinness of most wood-base panel materials precludes the use of the regular Janka-ball procedure (see Methods D143) unless several thicknesses are laminated together to provide a thickness of 1 in. (25 mm) or more.

18.2.2 This procedure is applicable for materials greater in thickness than $\frac{1}{8}$ in. (3 mm). For thicknesses $\frac{1}{8}$ in. or less, stacks of material may be used, but extreme care must be taken to select the proper slope for hardness modulus.

18.3 Test Specimen

18.3.1 Each specimen shall be nominally 3 by 6 in. (76 by 152 mm) in plane by the thickness of the material. When materials are $\frac{1}{4}$ in. (6 mm) or less in thickness, an extra specimen shall be prepared as a backing material during the test. The finished specimen shall be sawn square with smooth edges. The thickness of the specimens as tested shall be measured to an accuracy of $\pm 0.3\%$.

18.4 Procedure

18.4.1 The rate of penetration of the modified Janka-ball, 0.444 in. (11.3 mm) in diameter, shall be used for determining hardness modulus. See Note 39. Each test shall be continued until the penetration is about 0.1 in. (2.5 mm).

NOTE 39—Suitable modifications of the Janka-ball hardness apparatus to measure penetration are shown in Figs. 16 and 17. Fig. 16 shows the modification for manual measurements of penetration and Fig. 17 shows

³ For further information on this relationship consult “Hardness Modulus as an Alternate Measure of Hardness to the Janka Ball for Wood and Wood-Base Materials,” by W. C. Lewis, U.S. Forest Service, research note FPL-0189, March 1968. Available from Forest Products Laboratory, One Gifford Pinchot Dr., Madison, WI 53705-2398.

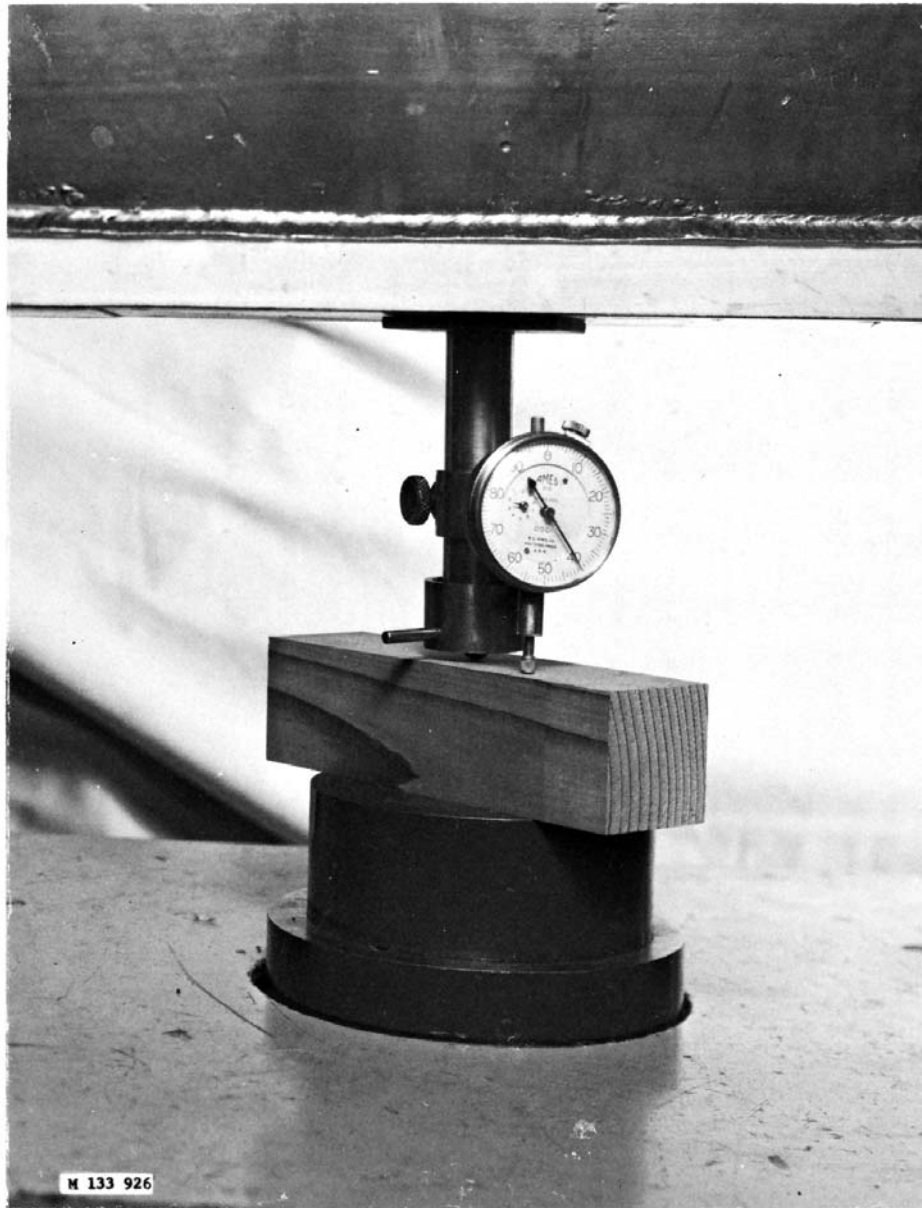

FIG. 16 Janka-Ball Hardness Tool Equipped with a Micrometer Dial for Measuring Penetration

a cone unit with microformer for autographic recording. Fig. 18 shows the kind of load-penetration data obtained from tests.

18.4.2 At least two penetrations shall be made on each of the two flat faces of each specimen. Where one face is different from the other as, for example, the smooth face and wire-textured back of most hardboards, the data obtained from the two faces shall be reported separately. The locations of the points of penetration shall be at least 1 in. (25 mm) from the edges and ends of specimens and far enough apart so that one penetration will not affect another one.

18.5 Speed of Testing

18.5.1 The load shall be applied continuously throughout the test at a uniform rate of motion of the movable crosshead of the testing machine of 0.05 in./min (1.3 mm/min) \pm 50 %. See Note 13.

18.6 Test Data and Report

18.6.1 The slope of the straight-line portion of the load penetration curve in pounds per inch shall be the hardness modulus. The equivalent Janka-ball hardness value in pounds is obtained dividing this hardness modulus by the factor 5.4.

18.6.2 The hardness modulus as determined from the load-penetration curve and the calculated equivalent Janka-ball hardness value shall be included in the report.

19. Shear in the Plane of the Panel

19.1 Scope

19.1.1 Shear tests shall be made on specimens prepared by laminating each specimen so that the plane of the shear failure will be in the panel proper and not in the glue lines. To evaluate directional properties, an equal number of specimens shall be

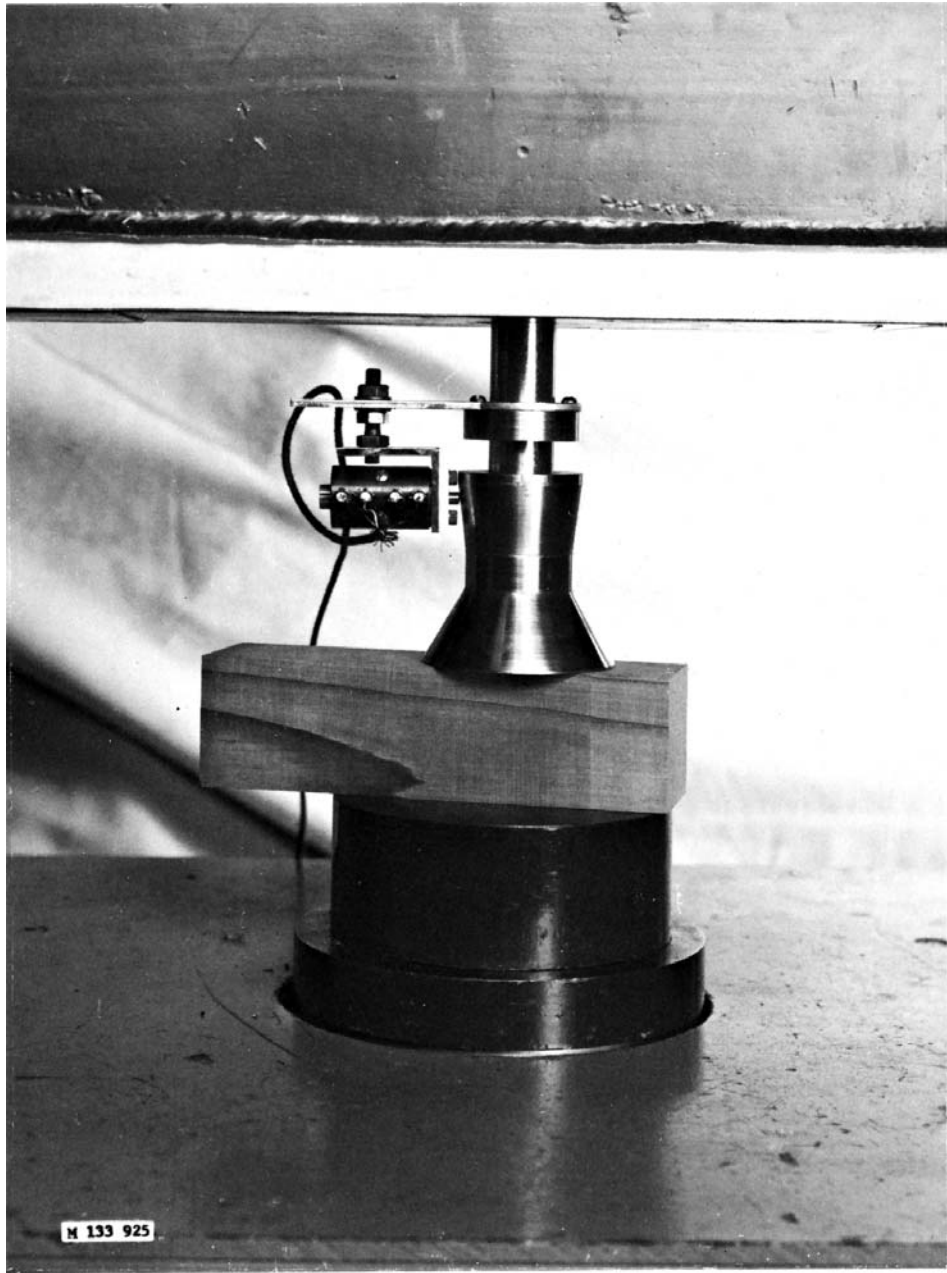

FIG. 17 Janka-Ball Hardness Tool Adapted with Cone and Microformer Unit for Direct Autographic Recording of Load-Penetration Data

tested with their long-axis parallel and perpendicular to the long-axis of the panel. This test, except for the method of preparing the specimen, follows the procedure described in Section 14 of Methods D143.

19.2 Test Specimen

19.2.1 The shear-parallel-to-plane of panel tests shall be made on 2 by 2 by 2½-in. (51 by 51 by 64-mm) specimens notched as illustrated in Fig. 19. It is the intent in this test to have the plane of shear parallel to the surfaces of the panel and to have the failure approximately midway between the two surfaces of the panel. The specimen shall be glued up by laminating sufficient thicknesses (see Note 40) of the panel together to produce the desired 2-in. (51-mm) thickness of

specimen as shown in Fig. 19. The actual area of the shear surface shall be measured to the nearest 0.005 in. (0.1 mm).

NOTE 40—When the shear strength of a thin panel like hardboard is desired, it will be permissible to use a thicker material such as plywood for outer laminations to reduce the total amount of gluing. When that procedure is used, at least the center lamination and preferably the three center laminations shall be of the panel under test.

19.3 Procedure

19.3.1 A shear tool with a self-aligning seat shall be used similar to that illustrated in Fig. 22 of Methods D143, providing a ⅛ in. (3-mm) offset between the inner edge of the supporting surface and the plane, along which failure occurs. The specimen shall be loaded at the notch, as indicated by the

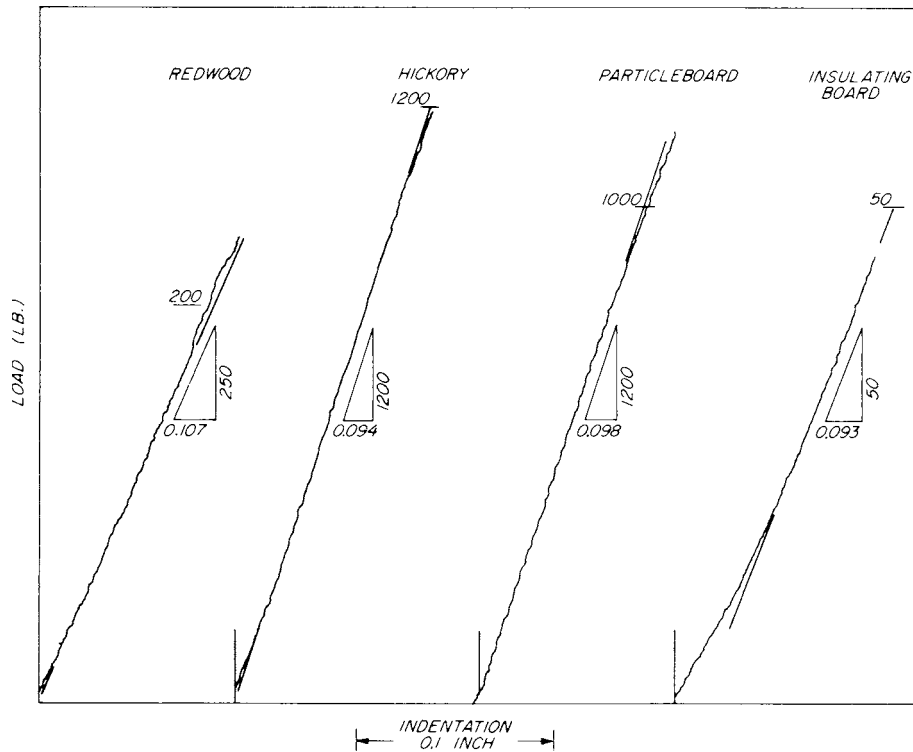
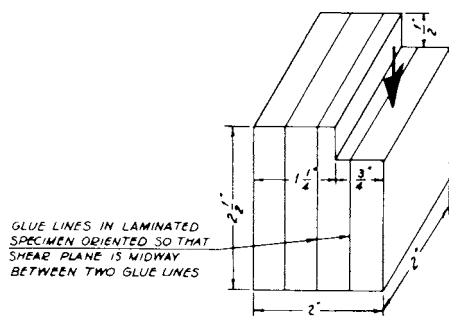

FIG. 18 Typical Load-Indentation Lines Obtained with Autographic Equipment for Wood and Wood-Base Panel Materials. Values Shown on Triangles Were Ones Used to Compute the Hardness Modulus Values



Metric Equivalents

in.	1/2	3/4	1 1/4	2	2 1/2
mm	12.7	19	31.7	51	63.5

FIG. 19 Shear Parallel to Surface Test Specimen

19.5.1 The maximum shear stress shall be calculated for each specimen in accordance with the following equation:

$$\tau = \frac{P_{max}}{bd} \quad (12)$$

where:

- b = width of the shear area measured in dry condition, in. (mm),
- d = depth of the shear area measured in dry condition, in. (mm),
- P_{max} = maximum load, lbf (N), and
- τ = maximum shear stress, psi (MPa).

19.5.2 The direction of loading, the character and type of failure, the maximum shear stress, the maximum load, and the shear area dimensions of each specimen shall be included in the report. In all cases where the failure at the base of the specimen extends back onto the supporting surface, the test shall be discarded.

20. Glue-Line Shear (Block Type)

20.1 Scope

20.1.1 The block-type glue-line shear test shall be used to evaluate glued panel constructions that are obtained when thicknesses are laminated together to provide a greater thickness than when manufactured. When desired, the specimens may be modified to evaluate glue lines between the test material and solid wood or veneer by laminating the specimen so that the glue line to be evaluated is so oriented in the specimen that it coincides with the plane of shear in the specimen. The shear blocks shall be fabricated such that the applied load will be parallel to the strong direction of the panel.

large arrow in Fig. 19, and supported at the opposite corner. Care shall be taken in placing the specimen in the shear tool to see that the crossbar is adjusted so that the edges of the specimen are vertical and the end rests evenly on the support over the contact area. The maximum load and the mode of failure shall be recorded.

19.4 Speed of Testing

19.4.1 The load shall be applied continuously throughout the test at a uniform rate of motion of the movable crosshead of the testing machine of 0.024 in./min (0.6 mm/min) \pm 50 %. See Note 13.

19.5 Calculation and Report

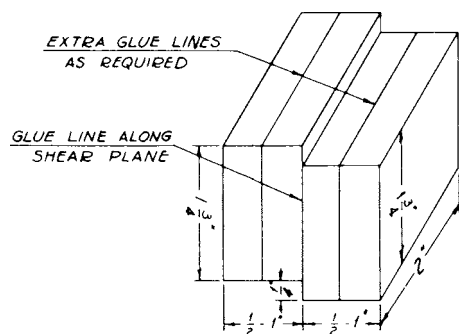

Metric Equivalents

in.	1/4	1	1 3/4	2
mm	6	25.4	44	51

FIG. 20 Block-Type Glue-Line Shear Test Specimen

This test procedure is adopted from Test Method D905, except for the rate of loading (see section 20.4).

20.2 Test Specimen

20.2.1 The test specimen shall be 2 in. (51 mm) in width and 2 in. (51 mm) in height, and shall be fabricated as shown in Fig. 20. The specimen shall be from 1 to 2 in. (25 to 51 mm) thick, depending on the thickness of the panel (see Note 41). Specimens shall be sawn from panels glued up in sizes of at least 6-in. (152-mm) square. Care shall be taken in preparing test specimens to make the loaded surfaces smooth and parallel to each other and perpendicular to the glue line in the shear plane. Care shall be exercised in reducing the lengths of the laminations to 1 3/4 in. (44 mm) to ensure that the saw cuts extend to, but not beyond the glue line. The width and height of the shear area of each specimen at the glue line shall be measured to the nearest 0.005 in. (0.1 mm).

NOTE 41—When the glue-line shear strength of a thin panel like hardboard is desired, it will be permissible to use a thicker material such as plywood for outer laminations to reduce the total amount of gluing. The material on either side of the glue line in the plane of shear shall be the panel under test unless the test involves a glue line of panel and another material.

20.3 Procedure

20.3.1 The specimen shall be loaded using the shearing tool with a self-aligning seat similar to that shown in Fig. 1 of Test Method D905, adjusted so that failure will occur along or adjacent to the glue line (no offset). Care shall be taken in placing the specimen in the shear tool to see that the crossbar is adjusted so that the edges of the specimen are vertical and the end rests evenly on the support over the contact area. The maximum load, mode of failure, and the percentage of fiber failure shall be recorded.

20.4 Speed of Loading

20.4.1 The load shall be applied with a continuous motion of the movable head of the testing machine at 0.024 in. (0.6 mm/min) ±50 %. See Note 13.

20.5 Calculation and Report

20.5.1 The maximum shear stress shall be calculated for each specimen in accordance with the following equation:

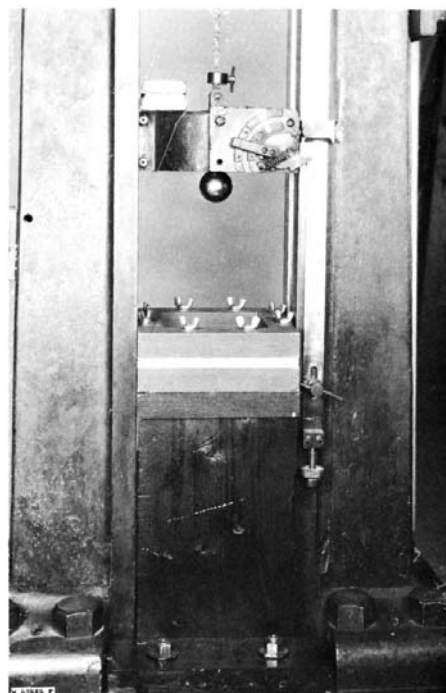

FIG. 21 Test Assembly for Falling Ball Impact Test

$$\tau = \frac{P_{max}}{bd} \tag{13}$$

where:

- b* = width of the shear area in dry condition, in. (mm),
- d* = depth of the shear area in dry condition, in. (mm),
- P_{max}* = maximum load, lbf (N), and
- τ* = maximum shear stress, psi (MPa).

20.5.2 The shear stress at failure, based on the maximum load, the shear area dimensions (the overlap area between the two laminations), and the percentage of fiber failure, for each specimen, shall be included in the report.

21. Falling Ball Impact

21.1 Scope

21.1.1 The falling ball impact test shall be used to measure the impact resistance of panels from the kind of damage that occurs in service when struck by moving objects. In this test a 2-in. (51-mm) diameter steel ball is dropped from increasing heights onto a specimen supported in a frame as described in section 21.2. Each drop is made at the same location on the specimen approximately in the center of the panel, until the panel fails. The height of drop in inches that produces a visible failure on the underside of the specimen is recorded as the index of resistance to impact.

21.2 Apparatus

21.2.1 A suitable assembly for making the falling ball impact test is shown in Fig. 21. Two frames of 1 1/2-in. (38-mm) thick plywood, 9 by 10-in. (228 by 254-mm) outside dimension with a 6-in. (152-mm) central square shall be provided with eight 3/8-in. (9-mm) carriage bolts for clamping the specimen between the frames. The eight bolts shall be spaced equidistant on 8 5/8-in. (218-mm) diameter circle. A 2-in. (51-mm) diameter

steel ball weighing 1.18 lb (535 g) and a suitable means of holding and releasing it from predetermined heights shall be provided. During the test the frame and specimen shall be supported solidly on a suitable base.

21.3 Test Specimen

21.3.1 The impact test specimens shall be 9 by 10 in. (228 by 254 mm) by the thickness of the material. No facing material other than that which is a regular part of the panel shall be applied to the panel prior to test. The thickness of the specimens as tested shall be measured to an accuracy of 0.001 in. (0.025 mm).

21.4 Procedure

21.4.1 The specimen shall be clamped securely between the frames. Drop the steel ball with an initial drop of 1 in. (25 mm) so that it strikes approximately at the center of the specimen. Make repeated drops from increasing heights until a visible fracture is produced on the top and bottom surface of the specimen. Increments of drop shall be 1 in. (25 mm), measuring the distance from the bottom of the ball to the top surface of the specimen. The heights of drop that produce visible fractures on each surface shall be recorded. Catch the ball after each drop so that there will be only one impact for each drop.

21.5 Report

21.5.1 The report shall include the following:

21.5.2 Description of the failure,

21.5.3 Heights of drop that produced failures on each surface, and

21.5.4 The measured thickness of each test specimen.

22. Abrasion Resistance by the U.S. Navy Wear Tester

22.1 Scope

22.1.1 Abrasion resistance tests shall be made on the panel to determine the wear under simulated conditions of uniform abrasion. See Note 42.

NOTE 42—Other test methods have been used to measure abrasion resistance of other materials. The test method delineated here has been used extensively for measuring the resistance of wood and other wood-base materials like plywood to surface abrasion.⁴

22.2 Test Specimen

22.2.1 The area of the test specimen to be abraded shall be 2 by 3 in. (51 by 76 mm), and the specimen shall be fabricated from a piece of the panel 2 by 4 in. (51 by 102 mm) by the thickness of the material as shown in Fig. 22. When the panel tested is less than 1/2 in. (12 mm) thick, either sufficient pieces shall be laminated together to provide the 1/2-in. thickness or the specimen shall be backed by a thickness of wood or plywood sufficient to provide the 1/2-in. total specimen thickness required. The specimens shall be air-conditioned before test (see section 6.3.2) and the test made in the same conditioned atmosphere. The actual dimensions of the abrading area of the specimen shall be measured to the nearest 0.01 in. (0.2 mm). The thickness of the test specimen shall be measured to the nearest 0.001 in. (0.025 mm) near each corner and the center.

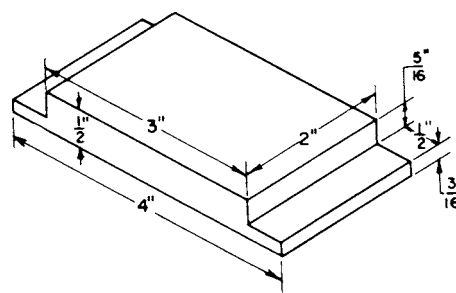

Metric Equivalents						
in.	3/16	5/16	1/2	2	3	4
mm	4.5	7.5	12.7	51	76	101.6

FIG. 22 Test Specimen for Abrasion Resistance Test

22.3 Procedure

22.3.1 Conduct the test with the Navy-type abrasion machine⁵ as shown in Fig. 23, using new No. 80-grit aluminum oxide, or equivalent, as the abrading medium. Apply the grit continuously (see Note 43) to the 14-in. (355-mm) diameter steel disk, which serves as a platform supporting the specimen and rotates at the rate of 23 1/2 r/min. Rotate the specimen in the same direction as the steel disk at the rate of 32 1/2 r/min. Superimpose a load of 10 lb (4.5 kg) on the test specimen. The machine is designed so that twice each revolution the specimen is raised 1/16 in. (1.6 mm) above the steel disk and immediately lowered. Determine the decrease in the thickness of the specimen at the end of each 100 revolutions of the steel disk by measuring the thickness of the specimen to the nearest 0.001 in. (0.025 mm) near each corner and at the center. Remove any dust or abrading material adhering to the surface of the specimen before measuring the thickness. The mean of the five thickness readings shall be taken as the loss in thickness of the specimen. Repeat this procedure until the specimen has 500 revolutions of wear or as required. See Note 44.

NOTE 43—The Navy wear tester is designed so that there is an excess of grit on the abrading disk at all times. During all parts of the abrading action, except when the specimen is in the raised position, the specimen is pushing a small amount of grit ahead of it.

NOTE 44—When values of accumulated wear are plotted as ordinates against revolutions, the slope of the curve is a straight line for wear through uniform materials. When the rate of wear per 100 revolutions of the abrading disk is not uniform after the first 200 revolutions, it is probably due to a change in abrasion resistance with depth from the original surface of the material being tested.

22.4 Report

22.4.1 The report shall include the following:

22.4.2 Loss in thickness in inches per 100 revolutions of wear if uniform, and

22.4.3 The loss in thickness in inches for each 100 revolutions if the amount of wear changes with depth from the original.

⁴ U.S. Forest Products Laboratory Report R1732, "The Abrasion Resistance of Wood as Determined with the U.S. Navy Wear Test Machine."

⁵ The Navy-type wear tester may be constructed from drawings obtainable from the U.S. Navy or the Forest Products Laboratory. It is manufactured commercially by the Tinius Olsen Testing Machine Co., Willow Grove, PA.



FIG. 23 Navy-Type Wear Machine for Abrasion Resistance Test

23. Water Absorption and Thickness Swelling

23.1 Scope

23.1.1 A test shall be made to determine the water-absorption characteristics of panels. For Method A (section 23.5) the water absorption and thickness swelling are expressed as a percent for the specimen after a 2-plus-22-h submersion. For Method B (section 23.6) the water absorption and thickness swelling are expressed as a percent for the specimen after a single continuous submersion time of 24-h. Method A, with its initial 2-h submersion period, provides information on the short term (2 h) and longer term (2-plus-22-h) water absorption and thickness swelling performance. Because Method A calls for a short removal period after 2 h, the values from Method A and Method B are not necessarily compatible.

23.2 Test Specimen

23.2.1 The test specimen shall be 12 by 12 in. (305 by 305 mm) or 6 by 6 in. (152 by 152 mm) by the thickness of the material with all four edges smoothly and squarely trimmed.

23.3 Conditioning Prior to Test

23.3.1 Prior to the test, the test specimens shall be in the “dry” condition in accordance with section 6.3.2. See Note 45.

NOTE 45—Conditioning prior to testing is not a common practice for quality control testing and some other circumstances. If the specimen is not conditioned to the defined parameters in section 6.3.2, the deviation from the conditioning requirement shall be reported.

23.4 Weight, Thickness, and Volume of Test Specimen

23.4.1 After conditioning, the weight of the specimen shall be measured to an accuracy of $\pm 0.2\%$. The width, length, and thickness of the specimen shall be measured to an accuracy of $\pm 0.3\%$ to compute the volume of the specimen. The thickness shall be measured at four points midway along each side 1 in. (25 mm) in from the edge of the specimen and the average of these four measurements shall be used for the thickness swelling determination (see Note 46).

NOTE 46—Where a common practice or special consideration requires thickness determinations at the edge or another distance from the edge, the edge distance used shall be reported. For textured surfaces, the surface area of the measuring device shall be of sufficient diameter as not to penetrate localized indentations of the textured surface.

23.5 Method A: 2-Plus-22-h Submersion in Water

23.5.1 The specimens shall be submerged horizontally under 1 in. (25 mm) of potable water maintained at a temperature of $68 \pm 2^\circ\text{F}$ ($20 \pm 1^\circ\text{C}$). See Note 47. Fresh water shall be used for each test. After a 2-h submersion, suspend the specimen to drain for 10 ± 2 min, then remove the excess surface water and immediately weigh the specimen and determine the thickness according to section 23.4. Submerge the specimen for an additional period of 22 h and repeat the above weighing and measuring procedures.

NOTE 47—As an alternative to the above method of submersion, the specimens may be submerged vertically. The amounts of water absorbed for tests of this duration are not the same for the two methods of submersion. Specimens suspended vertically will absorb considerably more water than those suspended horizontally. Therefore, values obtained from the horizontal and vertical methods are not comparable.

23.6 Method B: Single Continuous 24-h Submersion in Water

23.6.1 The procedure for determining water absorption after a 24-h submersion shall be the same as that provided in sections 23.2 through 23.5, except that only two sets of measurements are required, initial and after the 24-h submersion period.

23.7 Drying After Submersion

23.7.1 After submersion using Method A or B, the specimens shall be dried in an oven at $217 \pm 4^\circ\text{F}$ ($103 \pm 2^\circ\text{C}$) to determine the moisture content in accordance with Test Methods D4442.

23.8 Calculation and Report

23.8.1 The moisture content of the specimens before and after submersion shall be calculated based on oven-dry weight. Report shall include the size of the specimens and the description of the submersion procedure (Method A or Method B, horizontal or vertical submersion). The amount of water absorbed by the specimen during the submersion shall be calculated from the increase in weight and expressed as the percentage by volume and by weight based on the volume and the weight, respectively, after conditioning. Assume the specific gravity of the water to be 1.00 for this purpose. The thickness swelling shall be reported as a percentage of the conditioned thickness.

24. Linear Expansion with Change in Moisture Content

24.1 Scope

24.1.1 Tests of linear expansion with changes in moisture content shall be made to measure the dimensional stability of a panel with change in moisture content.

24.2 Test Specimen

24.2.1 The test specimens shall be 3 in. (76 mm) in width and at least 12 in. (305 mm) in length with the edges smoothly and squarely trimmed. If the panel is not large enough to permit a 12-in. (305-mm) specimen, the maximum length possible shall be used, but it shall be at least 6 in. (152 mm). Two

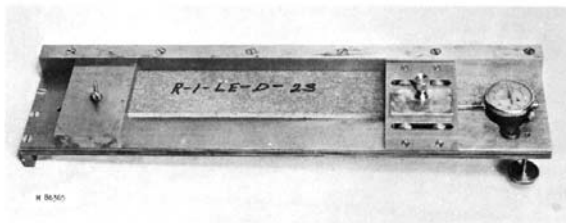

FIG. 24 Dial Gage Comparator for Determining Linear Expansion with Change in Moisture Content

specimens shall be cut from each panel, one specimen with the long side parallel to the long dimension of the panel and the other specimen—perpendicular.

24.3 Procedure

24.3.1 Specimens shall be conditioned to practical equilibrium (see [Note 48](#)) at a relative humidity of $50 \pm 2\%$ and a temperature of $68 \pm 6^\circ\text{F}$ ($20 \pm 3^\circ\text{C}$) and the length of each specimen shall be measured to the nearest 0.001 in. (0.02 mm). Then the specimens shall be conditioned to practical equilibrium at a relative humidity of $90 \pm 5\%$ and a temperature of $68 \pm 6^\circ\text{F}$ ($20 \pm 3^\circ\text{C}$) and the length shall be measured again to the nearest 0.001 in. (0.02 mm). See [Notes 49 and 50](#). For each measurement the specimen shall be oriented in the same way (for example, numbered surface up with numbers reading from the side toward the operator). See [Note 51](#).

NOTE 48—Practical equilibrium is defined as the state of time-change in weight where for practical purposes the specimen is neither gaining nor losing moisture content more than 0.05 weight percent in a 24-h period. It is helpful in determining the end point in conditioning to plot weight change against time. When the curve becomes asymptotic to a horizontal line, practical equilibrium is indicated.

NOTE 49—Where values of linear change with change in moisture content associated with exposure to a greater humidity change are desired, equilibrium at a relative humidity of $30 \pm 1\%$ may be used for the lower humidity condition rather than the 50% specified in this section. The report shall state the actual humidity conditions used. When the change between 30 and 90% relative humidity is desired, it is suggested the specimens be prepared in pairs, conditioned at 50% relative humidity, and then one specimen of each pair be conditioned at 90% relative humidity and the other at 30% relative humidity.

NOTE 50—Certain wood products experience difficulty reaching an equilibrium moisture content when exposed to 90% relative humidity, making the standard 50 to 90% relative humidity test method unreliable. As an alternative to the standard 90% upper relative humidity level, equilibrium at $80 \pm 3\%$ may be used. The coefficient of variability for linear expansion tested with an 80% upper relative humidity should be less than that of the 90% relative humidity test because of the smaller allowable range in endpoint relative humidity and the possible differences in hygroexpansivity of a given material between 80 and 90% relative humidity.

NOTE 51—[Figs. 24 and 25](#) provide details of a dial gage comparator that may be used for measuring linear expansion with change in moisture content. Any equally or more accurate measurement procedure may be used.

24.4 Calculation and Report

24.4.1 The linear expansion with change in moisture content shall be reported as the percentage change in length based on the length at 50% relative humidity. The report shall include the conditions used. When change in length from 30 to 90% (or 30 to 80%) relative humidity is desired, this may be

estimated with sufficient accuracy by adding the changes in length between 50 and 90% (or 50 and 80%) and 50 and 30% relative humidity.

25. Cupping and Twisting

25.1 Scope

25.1.1 When required, measurements of cupping and twisting shall be made after accelerated aging (see [Section 7](#)).

25.2 Test Specimen

25.2.1 The test specimen shall be 12-in. (305-mm) square by the thickness of the material with all four edges smoothly and squarely trimmed. The dimensions of the specimen shall be measured to an accuracy of $\pm 0.3\%$.

25.3 Procedure

25.3.1 Cupping shall be determined by placing a straight-edge across opposite edges of the specimen, and measuring the maximum distance to the concave face to the nearest 0.001 in. (0.02 mm).

25.3.2 Twisting shall be determined by placing the specimen with three corners touching a level surface and measuring the distance from the raised corner to the surface to the nearest 0.001 in. (0.02 mm).

25.4 Report

25.4.1 The report shall include the size of specimens and necessary details regarding methods and results of measurements.

26. Interlaminar Shear

26.1 Scope

26.1.1 Tests in interlaminar shear (shear in the plane of the panel) shall be made on specimens bonded between two steel loading plates loaded in compression on the edge to obtain shear strength and deformation properties of the panel. To evaluate directional properties, an equal number of specimens shall be tested with their long-axis parallel and perpendicular to the long-axis of the panel.

26.2 Significance and Use

26.2.1 Shear properties in the plane of the panel (interlaminar shear) duplicate the kind of shear stress encountered in such glued structural assemblies as structural sandwiches and adjacent to gluelines between flanges and webs in box-beams and I-beams and gusset plates in trusses. The procedure used follows closely the requirements of [Test Method C273](#). While it apparently yields values in the same plane as the “block shear” test of [Section 20](#), values obtained are not comparable because of effects of friction in the block shear tool and the fact that failure in the block shear test can only occur in a $\frac{1}{8}$ -in. (3-mm) thick area in the middle of the specimen. The interlaminar shear strength test offers the additional advantage that shear deformation data can be obtained when desirable.

26.3 Test Specimen

26.3.1 The interlaminar shear tests shall be made on specimens 2 by 6 in. (51 by 152 mm) by the thickness of the material, when the panel material is $\frac{1}{2}$ in. (12.5 mm) in thickness or less. For materials greater than $\frac{1}{2}$ -in. (12.5-mm) thick, the specimen shall have a width of at least twice the thickness but not less than 2 in. (51 mm) and a length at least

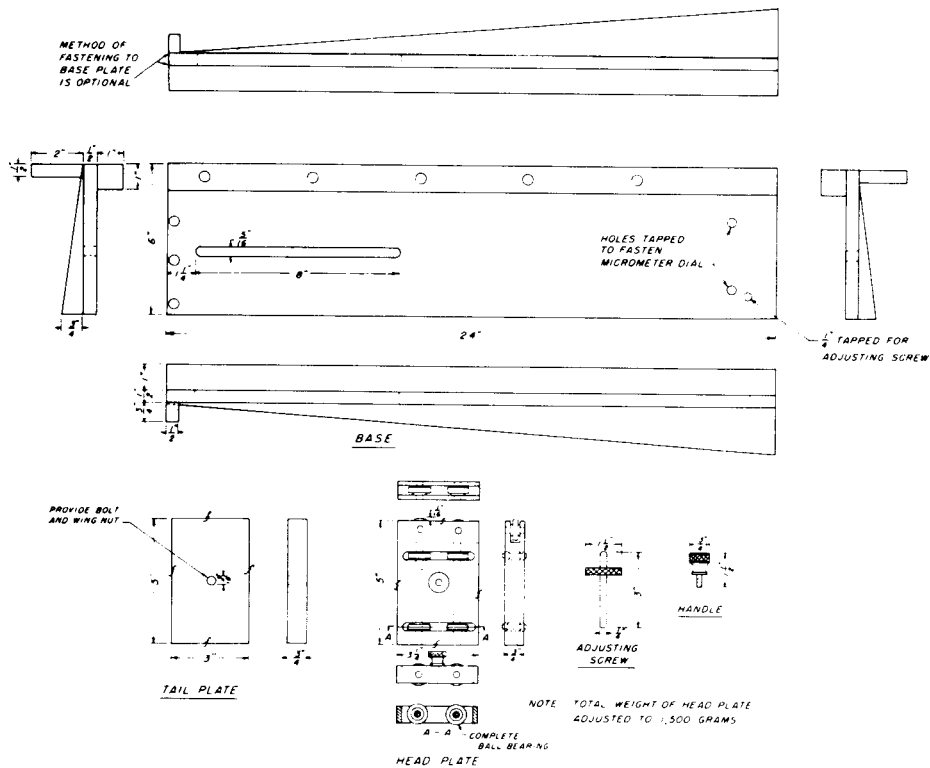

NOTE 1—1 in. = 25.4 mm.

FIG. 25 Details of Dial Gage Comparator for Measuring Linear Expansion with Change in Moisture Content

12 times the thickness (see Note 51). The edges of the specimen shall be sawn square and smooth. The length and width shall be measured to an accuracy of $\pm 0.3\%$. The thickness shall be measured to an accuracy of 0.001 in. (0.025 mm).

26.3.2 Steel loading plates $\frac{3}{4}$ -in. (19-mm) thick, having a width equal to the specimen width and a length equal to the specimen length plus $\frac{1}{4}$ in. (7 mm) shall be bonded to each face of the specimen as shown in Fig. 26 using suitable adhesive (see Note 20). The loading ends of the plates shall project $\frac{1}{4}$ in. (7 mm) beyond the end of the specimen and they shall be beveled at 45° and oriented as shown. Use minimum spreads and extreme care when applying adhesive to prevent infusing into the specimen and thus reinforcing the panel.

NOTE 52—A length ratio of 12:1 is prescribed as a minimum so that secondary normal stresses are minimal.

26.4 Procedure

26.4.1 The load shall be applied through notched fittings such that the line of action of the direct compressive force shall pass through the diagonally opposite corners of the specimen as shown in Fig. 26. The lower fitting shall be placed on a spherical bearing block as shown in Fig. 27 so that the load is uniformly distributed across the width of the specimen.

26.5 Speed of Testing

26.5.1 The load shall be applied continuously throughout the test at a uniform rate of motion of the movable crosshead of the testing machine equal to 0.002 times the length in./min (mm/min) $\pm 50\%$. See Note 13.

26.6 Load-Deformation Data

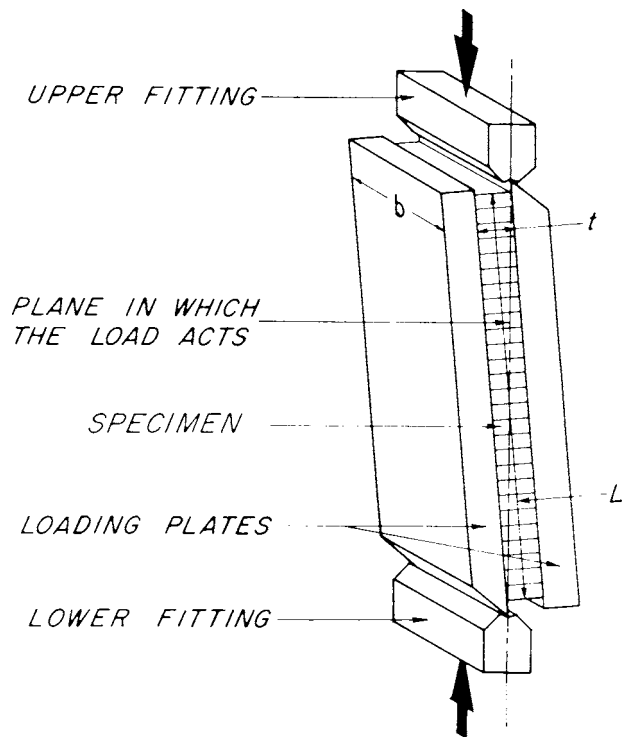

FIG. 26 Detail of Specimen and Loading Apparatus for Determining Interlaminar Shearing Properties

26.6.1 When shear modulus is required, data for plotting load-deformation curves can be obtained by using the arrangement shown in Fig. 27, which measures the displacement of

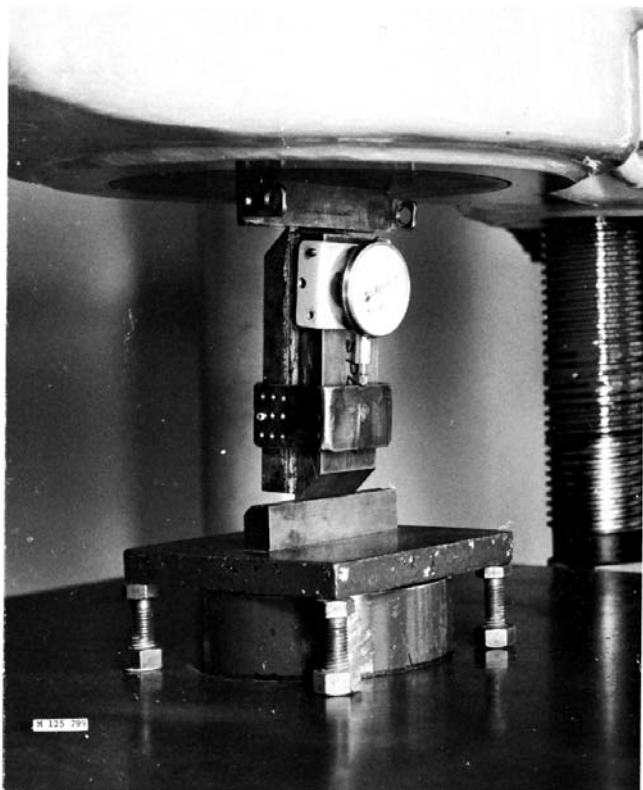

FIG. 27 Test Assembly for Determining Interlaminar Shearing Properties, Showing Dial Gage Apparatus for Measuring Shear Displacement

one plate with respect to the other. Displacement can be measured by the dial gage or microformer.

26.7 Calculation and Report

26.7.1 The interlaminar shear strength and, when required, the interlaminar shear modulus shall be calculated for each specimen in accordance with the following equations, and the values determined shall be included in the report:

$$f_s = \frac{P_{max}}{bL} \quad (14)$$

$$G = \frac{d}{bL} \frac{\Delta P}{\Delta y} \quad (15)$$

where:

b = width of specimen measured in dry condition, in. (mm),

d = thickness of specimen measured in dry condition, in. (mm),

f_s = interlaminar shear strength, psi (MPa),

G = interlaminar shear modulus, psi (MPa),

L = length of specimen measured in dry condition, in. (mm),

P_{max} = maximum load, lbf (N), and

$\frac{\Delta P}{\Delta y}$ = slope of the straight line portion of the load-deformation curve (see Note 17 and Note 53), lbf/in. (N/mm).

NOTE 53—Eq 15 assumes that the strains in the loading plates and in the bond between the plates and the specimen are negligible.

26.7.2 A secant modulus may be calculated for data that do not have an initial straight-line relationship. Then $(\Delta P/\Delta y)$ is the slope of the secant of the load-deformation curve in a given range. The method used to determine shear modulus shall be reported.

27. Edgewise Shear

27.1 Scope

27.1.1 Tests in edgewise shear (shear normal to the plane of the panel, or panel shear) shall be made on specimens clamped between two pairs of steel loading rails. These rails when loaded in axial compression or tension introduce shear forces in the specimen that produce failures across the panel. With most panel materials, failure is a combination of diagonal tension and compression. To evaluate directional properties, an equal number of specimens shall be tested with their long-axis parallel and perpendicular to the long-axis of the panel.

27.2 Significance and Use

27.2.1 This test produces the kind of shear stress that occurs when shear forces are introduced along the edges of the material. The usual applications are where the panel is used as sheathing and racking forces are involved. When panel areas are large with respect to thickness, buckling may occur due to diagonal compressive forces. When this is so, actual panel shear strength may be lower than determined from this test.

27.3 Test Specimen

27.3.1 Each specimen, 3½ by 10 in. (89 by 254 mm) by the thickness of the material, shall be prepared as shown in Fig. 28. The thickness and length of the specimen shall be measured to an accuracy of ±0.3 %.

27.4 Procedure

27.4.1 The load shall be applied in either tension or compression such that the line of action of the applied force passes through diagonally opposite corners of a 1-in. (25-mm) wide by 10-in. (254-mm) long shear area. The ¼ in. (32 mm) width on either side of the shear area shall be used to grip the panel using friction. See Note 54.

NOTE 54—This test procedure is commonly executed using pneumatic or hydraulic gripping devices through which a tension force is applied across the shear area. As an alternative, the bolted grips such as those pictured in Fig. 29 may be used. These grips use hardened steel loading rails with serrated gripping surfaces and are bolted to the specimen with eight ⅜-in. (10 mm) high-strength bolts. The bolts are tightened to prevent the rails from slipping when the load is applied so as to avoid bolt-bearing failures in the panel material. The pressure necessary to prevent slipping will depend upon the density of the material. In order to obtain sufficient gripping pressure when testing some low-density panels, a certain amount of crushing of the specimen beneath the loading rails is unavoidable. The lower fitting is placed on a spherical bearing block so that the load is applied uniformly. The upper fitting is positioned directly above the lower fitting; thus the direct compressive force is applied vertically as shown in Fig. 30.

27.5 Speed of Testing

27.5.1 The load shall be applied continuously throughout the test at a uniform rate of motion of the movable crosshead of the testing machine of 0.02 in./min (0.5 mm/min) ±50 %. See Note 13.

27.6 Calculation and Report

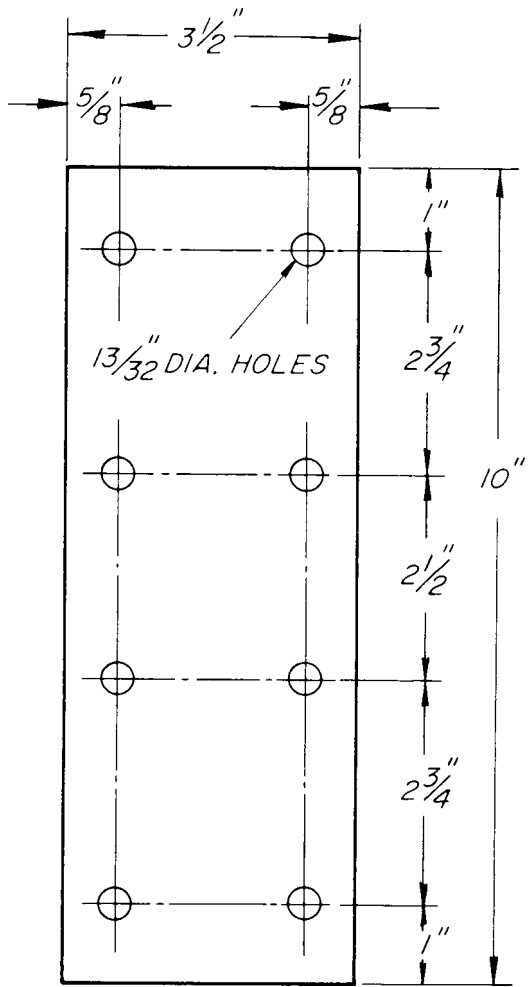

FIG. 28 Detail of Edgewise Shear Specimen

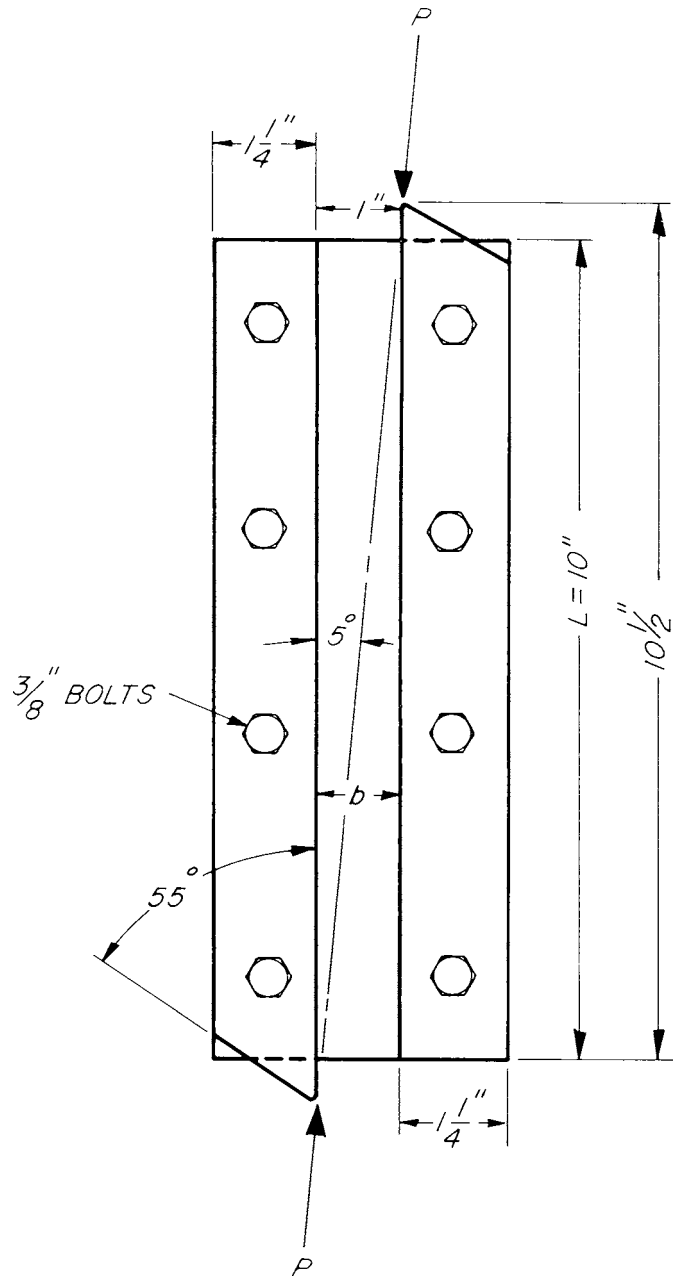

FIG. 29 Detail of Loading Rails Used with Edgewise Shear Specimen

27.6.1 The edgewise shear strength shall be calculated for each specimen in accordance with the following formula, and the values determined shall be included in the report:

$$f_s = \frac{P_{max}}{dL} \quad (16)$$

where:

- d = thickness of specimen measured in dry condition, in. (mm),
- f_s = edgewise shear strength, psi (MPa),
- L = length of specimen measured in dry condition, in. (mm), and
- P_{max} = maximum compressive load, lbf (N).

27.6.2 Report shall include the description of test apparatus, direction of loading (compression or tension), and calculated values. The kind of failure shall also be described.

28. Compression-Shear

28.1 Scope

28.1.1 This test destructively determines the compressive-shear strength of a panel specimen without gluing or clamping. It provides an indication of the bond quality of a material

subjected to shear deformation, which correlates to the tensile strength perpendicular-to-surface (internal bond) test (Section 11).

28.1.2 It is appropriate for specimens from 1/4 in. (6.4 mm) to 15/16 in. (33.3 mm) in thickness if the panel exhibits sufficient compressive strength perpendicular to the surface so that the primary mode of failure is shear in a plane nearly parallel to the surface.

28.1.3 The specimen may be tested with the shear stress applied parallel or perpendicular to the panel length, or at any angle in between.

28.2 Summary of Test Method

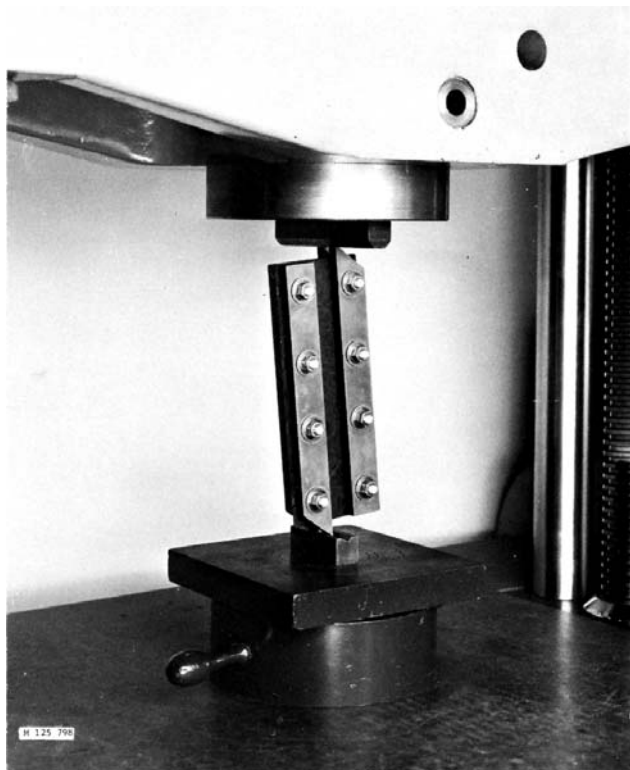

FIG. 30 Test Assembly for Determining the Edgewise Shearing Strength of Wood-Base Panel Products

28.2.1 The test employs the principle that an axially loaded column develops maximum shear stress at an angle 45° to the direction of an applied compressive load. A short columnar assembly of upper and lower sections, to which a compressive load is applied at a uniform rate, is formed by placing a specimen between friction surfaces of mating shear jaws that are oriented at 45° to the axis of the column (Fig. 31). Components of the applied load subject the specimen to compression stress perpendicular to the surface, and shear stress parallel to the surface of the specimen. The shear jaws can be adjusted so that the applied load is always directed through the geometric center of the test specimen. The surfaces of the jaws are designed to transfer the shear force to the specimen. Removable restraining bars, one on the upper end of the upper-shear jaw, and one on the lower end of the lower-shear jaw position the specimen for testing, and also transmit some shear if transfer by the jaw surfaces is incomplete. The base of the lower section of the test column rides on a journaled-roller assembly that permits unrestrained lateral movement to occur as shear strain develops. A hemispherical-pivot point is attached to the top of the upper section of the test column to enable unevenly thick or improperly cut specimens with slight dimensional variations to be tested without modification.

28.3 Significance and Use

28.3.1 The intent of the compression-shear test method is to provide a quick, simple, reproducible, and quantitatively accurate means for measuring the bond quality of panel products.

28.3.2 Panel producers can use it to monitor quality control, and secondary manufacturers and researchers can evaluate the relative strength of panels with similar particle geometries.

28.3.3 The results of the compression shear test can be used directly as a measure of bond quality, or the results may be correlated, using appropriate statistical procedures, to those of the tensile strength perpendicular-to-surface test outlined in Section 11.

28.4 Interferences

28.4.1 The configuration of the test specimen results in some non-uniformity of stress across and through the specimen. Thus, the plane of maximum shear is not precisely parallel to the panel face. However, results correlate well with the common method of evaluating bond quality as specified in Section 11.

28.4.2 Shear failure should occur near the center plane of the specimen. When shear failure occurs on, or near the surface of the specimen, it may not be indicative of a poorly bonded face, since stress concentrations at the interface of the bar, and specimen may initiate unwarranted failure.

28.4.3 When shear failure occurs at or near the specimen's surface, a verification test with a representative specimen shall be conducted as directed in Section 11 to determine if the surface is actually the weakest plane.

28.4.4 Panel types having different particle geometries or orientations, but the same tensile strength perpendicular-to-surface values (Section 11), may have different compression-shear values. Therefore, it may be necessary for each user to develop specific correlations for each panel type to be tested.

28.4.5 Particles aligned perpendicular to the shear force may fail in rolling shear, determined by wood strength, not bond strength.

28.4.6 When bond strength of oriented strand board (OSB) is desired, the test specimen shall be cut so that the orientation of all layers of the specimen is aligned at 45° to the shear force.

28.5 Apparatus

28.5.1 The compression-shear test apparatus consists of the compression-shear device, illustrated in Fig. 32, and any machine (see Note 55) that can apply a compressive force measurable within $\pm 2\%$ accuracy at a rate that will develop 5000 lbf (22 000 N) within 4 ± 2 s, when platens or crosshead and load cell are in contact with a $5/8$ -in. (149-mm) diameter $7/8$ -in. (22-mm) or thicker steel plate.

NOTE 55—Experience indicates that a machine with a 5000 lbf load capacity should be sufficient for testing commercially produced commodity panel types. However, high strength experimental, or specialty-panel types may require a machine capacity of up to 10 000 lbf.

28.6 Test Specimen

28.6.1 Test specimen shall be a $2 \pm 1/16$ -in. (51 ± 1.6 -mm) wide rectangle with all edges trimmed smoothly and squarely. The length, $\pm 1/16$ in. (± 1.6 mm), shall be determined in accordance with thickness as listed in Table 2.

28.6.2 A specimen that is to be tested in a swollen state may be cut before or after swelling. For a specimen to be tested in the swollen state and cut prior to swelling, the thickness of the specimen as it will be tested shall be anticipated in order to establish specimen length. To compensate for any anticipated

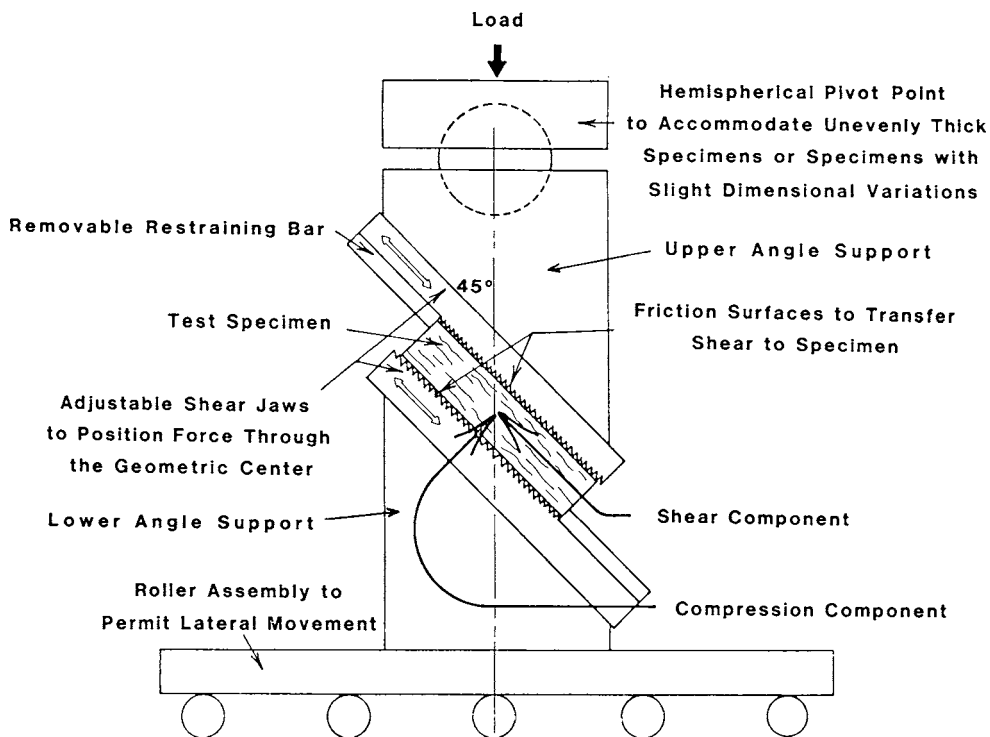

FIG. 31 Principle of Compression-Shear Test

TABLE 2 Specimen Length as a Function of Thickness^A

Thickness Range, in. (mm)	Length, in. (mm)
0.250 to 0.312 (6.35 to 7.93)	2.000 (50.80)
0.313 to 0.437 (7.94 to 11.10)	2.125 (53.98)
0.438 to 0.562 (11.11 to 14.28)	2.250 (57.15)
0.563 to 0.687 (14.29 to 17.45)	2.375 (60.33)
0.688 to 0.812 (17.46 to 20.63)	2.500 (63.50)
0.813 to 0.937 (20.64 to 23.80)	2.625 (66.68)
0.938 to 1.062 (23.81 to 26.98)	2.750 (69.85)
1.063 to 1.187 (26.99 to 30.15)	2.875 (73.03)
1.188 to 1.312 (30.16 to 33.32)	3.000 (76.20)

^A The thickness at the time of testing is the basis for establishing length. For example, a specimen 0.520-in. (13.21-mm) thick shall be 2.250-in. (57.2-mm) long. In instances where the thickness variation of a group of similar specimens would dictate cutting specimens of different lengths, the length of all specimens in the group shall be governed by the thickest specimen. For example, in a group composed of two specimens that individually measure 0.410 and 0.465-in. (10.4 and 11.8-mm) thick, each specimen shall be 2.250-in. (57.2-mm) long.

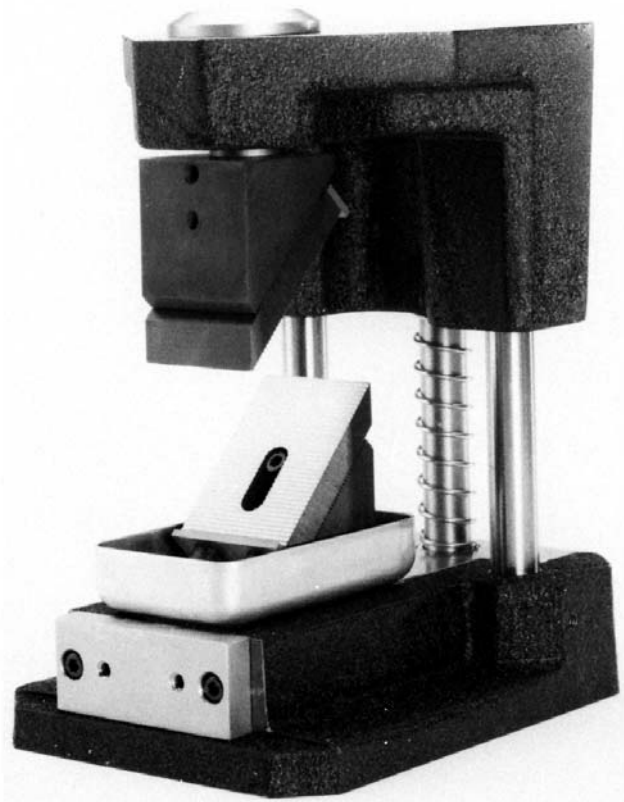

FIG. 32 Compression-Shear Device

change in length, the length shall be increased or decreased by the amount of the anticipated change.

28.6.3 Individual agencies promulgating the compression-shear test as a quality control test shall decide what method of wetting shall be appropriate. Otherwise, users shall decide the appropriate method, and shall include it in report.

28.6.4 The length, width, thickness, and weight of each specimen shall be measured prior to test to an accuracy of $\pm 0.3\%$.

28.7 Procedure

28.7.1 Symmetrically position the upper- and lower-shear jaws, with restraining bars attached, so that the applied force will be directed through the geometric center of the test specimen.

28.7.2 The correct positioning of a specimen can be checked by marking, and aligning the specimen as follows:

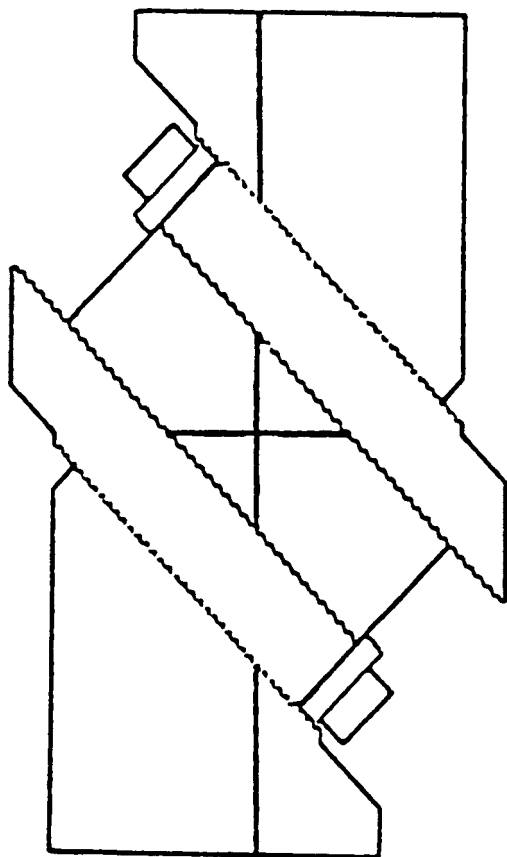

FIG. 33 Proper Positioning of Test Specimen and Shear Jaws on Angle Supports

Use a 45/90° square to determine the geometric center of the long edge of the specimen and draw two 45° lines through this point to form an X.

28.7.3 Place the test specimen flush against the lower-restraining bar and shear jaw, and position the lower-shear jaw so that the indicator line on the lower-angle support is aligned with the vertical line on the test specimen; then position the upper-shear jaw so that the indicator line of the upper-angle support is aligned with the same line on the test specimen when each shear jaw's face and restraining bar are flush with the test specimen, as illustrated in Fig. 33.

28.7.4 Position the compression-shear device in the testing machine that will apply the compressive load.

28.7.5 Place a test specimen in the device; apply a compressive load at the rate specified in section 28.5, and record the maximum load to failure.

28.8 Calculation and Report

28.8.1 Assume that the shear area is the product of the measured length and width dimensions, even when the plane of failure is not parallel to the surface.

28.8.2 Calculate the maximum shear stress for each specimen in accordance with the following equation:

$$\tau = \frac{P_{max}}{\sqrt{2}bd} \quad (17)$$

where:

b = width of the specimen, in. (mm),

d = length of the specimen, in. (mm),

P_{max} = maximum load, lbf (N), and

τ = maximum-shear stress, psi (MPa).

28.8.3 The report shall include the following:

28.8.4 The brand name and model number of the machine used to apply the compressive load, and how the load was delivered, that is, through manual or motorized application.

28.8.5 The actual length, width, and thickness of the specimen, in. (mm).

28.8.6 The orientation of panel length, or machine direction to the direction of shear stress.

28.8.7 Special conditions of test, if any (see 28.6.3).

28.8.8 The maximum load, lbf (N).

28.8.9 The maximum shear stress, psi (MPa) for each specimen as calculated in section 28.8.2.

28.8.10 The percent moisture content at time of test as determined in accordance with section 8.4.

PART B—ACCEPTANCE AND SPECIFICATION TEST METHODS FOR HARDBOARD

29. Test Panel

29.1 A test panel of minimum dimensions of 40 by 48 in. (1.0 by 1.2 m) shall be sawn for each test panel whenever possible. The 48-in. dimension of the test panel shall be across the longer dimension of the panel as it is usually obtained. When the test panels are less than 40 by 48 in. in size, a sufficient number of panels shall be selected for each test series to yield the equivalent number of specimens, as shown in Fig. 34.

30. Test Specimens

30.1 Specimens shall be sawn from the test panel, as shown in Fig. 34, exercising care so that edges are straight, smooth, and square, and so that ends and sides are mutually perpendicular to each other.

31. Conditioning

31.1 Except in case of disputes, test all specimens at the moisture content as shipped or received. In cases of dispute, condition the specimens to a constant weight prior to testing, at a relative humidity of 50 ± 2 % and a temperature of 72 ± 2°F (22 ± 1°C).

32. Thickness

32.1 Apparatus

32.1.1 Any thickness measuring instrument on which the contacting surfaces are flat and have a minimum diameter of 7/16 in. (11 mm) shall be used. Pressure on the contacting surfaces shall be not less than 7 psi (48 kPa) nor greater than 12 psi (83 kPa), and the instrument shall be such that determinations of thickness are accurate to 0.001 in. (0.02 mm).

32.2 Test Specimen

32.2.1 Twelve 3 by 6-in. (76 by 152-mm) modulus-of-rupture specimens, as specified in section 33.2, shall be used for the determinations of thickness.

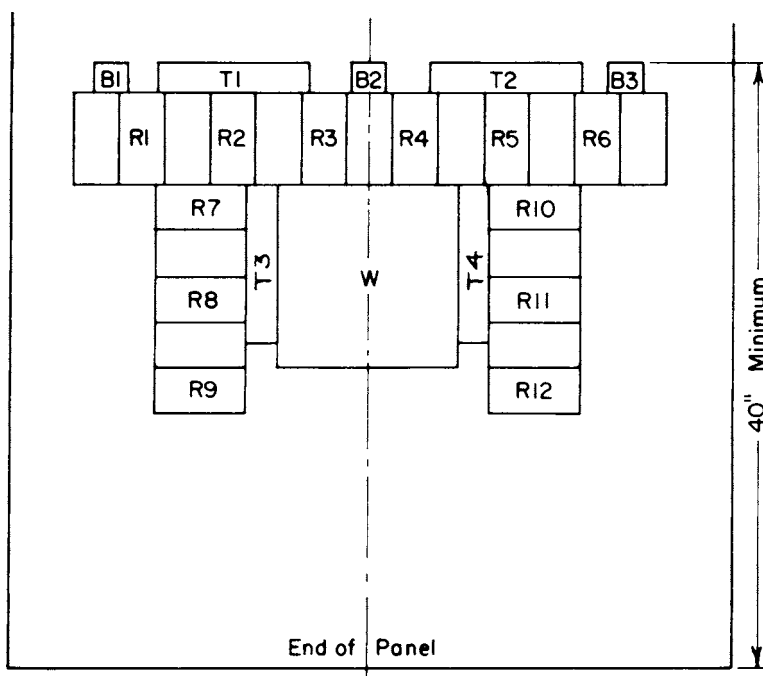

Modulus of rupture (*R*)—twelve 3 by 6 in. (76 by 152 mm)
 Tension parallel to surface (*T*)—four 2 by 10 in. (51 by 254 mm)
 Tension perpendicular to surface (*B*)—three 2 by 2 in. (51 by 51 mm)
 Water absorption and swelling (*W*)—one 12 by 12 in. (304 by 304 mm)

NOTE 1—The suffix numbers may be used to identify individual specimens by location and to record specimen test data.

FIG. 34 Diagram for Cutting Test Specimens from Hardboard Test Panel

32.3 Procedure

32.3.1 Measure the thickness at two points on each specimen approximately 1 in. (25 mm) in from the center of the long edges to the nearest 0.001 in. (0.02 mm).

32.4 Calculation and Report

32.4.1 Report the average thickness of the twelve specimens for each test panel to the nearest 0.001 in. (0.02 mm).

33. Modulus of Rupture

33.1 Apparatus

33.1.1 *Testing Machine*—Any standard testing machine (see Note 1) capable of applying and measuring the load with an error not to exceed $\pm 1.0\%$, as provided in Practices E4.

33.1.2 *Span and Supports*—The span shall be 4 in. (102 mm) from center to center of the supports when testing nominal thicknesses not less than $\frac{1}{10}$ in. (2.5 mm) nor greater than $\frac{3}{8}$ in. (9.5 mm). For thicknesses less than $\frac{1}{10}$ in. a span of 2 in. (51 mm) shall be used. The supports and loading block shall be rounded to a radius of not less than $\frac{3}{16}$ in. (5 mm) nor more than $\frac{3}{8}$ in. (10 mm) and shall be at least 3 in. (76 mm) long.

33.2 Test Specimen

33.2.1 The test specimen shall be 3 by 6 in. (76 by 152 mm) by the thickness of the panel. Six specimens with the long dimension parallel and six specimens with the long dimension perpendicular to the long dimension of the panel shall be taken for testing, as shown in Fig. 34.

33.3 Procedure

33.3.1 *Thickness*—The thickness of each specimen shall be measured to the nearest 0.001 in. (0.025 mm) using the apparatus and procedure specified in Section 34.

33.3.2 *Width*—The width of each specimen shall be measured to the nearest 0.01 in. (0.25 mm) at the line of load application.

33.3.3 *Load Application*—The specimen shall be centered flatwise on the parallel supports. The specimen shall be placed for testing so that the screen, or rough side, or back surface of sanded two side (S2S) panels when it can be determined, is placed in tension.

33.3.4 *Speed of Testing*—The load shall be applied continuously at midspan at an approximately uniform rate of motion of the movable crosshead such that the outer fiber strain rate is 0.02 in./in./min (0.02 mm/mm/min). The rate of motion of the crosshead shall be calculated in accordance with Eq 1. See Notes 56 and 57. The crosshead speed, adjusted for thickness, shall not vary by more than $\pm 50\%$ from that specified for a given test. The speed of testing shall be recorded on the data sheet.

NOTE 56—Based on Eq 1, the calculated speed of the crosshead to achieve an outer fiber strain rate of 0.02 in./in./min is approximately:

0.13 in./min (3.3 mm/min)	for $\frac{1}{10}$ -in. (2.5-mm) thickness, 2-in. (51-mm) span
0.14 in./min (3.6 mm/min)	for $\frac{3}{8}$ -in. (9.5-mm) thickness, 4-in. (102-mm) span

NOTE 57—This speed is the differential speed between the moving crosshead and the supports.

33.3.5 The load shall be applied until definite failure occurs. The maximum load shall be recorded to accuracy of the testing machine.

33.4 Calculation and Report

33.4.1 The modulus of rupture shall be calculated for each specimen in accordance with the following equation:

$$R_b = \frac{3P_{max}L}{2bd^2} \quad (18)$$

where:

- b = width of specimen, in. (mm),
- d = thickness of specimen, in. (mm),
- L = length of span, inch (mm),
- P = maximum load, lbf (N), and
- R_b = modulus of rupture, psi (MPa).

33.4.2 The average modulus of rupture of the twelve specimens for each test panel shall be reported to the nearest 100 psi (0.5 MPa).

34. Tension Parallel to Surface

34.1 Procedure

34.1.1 The procedure for determining tension parallel to surface shall be the same as that provided in Section 10, except that the uniform rate of separation of the jaws of the tensile grips shall be 0.15 ± 0.025 in./min. (3.8 ± 0.6 mm/min.). From each test panel, two specimens shall be selected with the long dimension parallel and two specimens with the long dimension perpendicular to the long dimension of the test panel, as shown in Fig. 34. The thickness of each specimen shall be measured to the nearest 0.001 in. (0.02 mm) and the width to the nearest 0.01 in. (0.2 mm).

34.2 Calculation and Report

34.2.1 The tension shall be calculated for each specimen in accordance with Eq 6.

34.2.2 The average tension of the four specimens for each test panel shall be reported to the nearest 100 psi (0.5 MPa).

35. Tension Perpendicular to Surface

35.1 Procedure

35.1.1 The procedure for determining tension perpendicular to surface shall be the same as that provided in Section 11, except that the uniform rate of separation of the heads of the testing machine shall be 0.15 ± 0.025 in./min. (3.8 ± 0.6 mm/min.). From each test panel, three specimens shall be selected for test as shown in Fig. 34. Saw each test specimen accurately so that it is 2.00 ± 0.01 in. (50.8 ± 0.2 mm) on a side. If improper adhesion of the metal loading blocks to the specimen is indicated by less than 95 % fiber transfer at failure, the tests shall be repeated using supplemental specimens obtained from the same general area of the test panel as the original specimens.

35.2 Calculation and Report

35.2.1 The tension perpendicular to surface shall be calculated for each specimen in accordance with Eq 7.

35.2.2 The average tension of the three specimens from each test panel shall be reported to the nearest 5 psi (0.05 MPa).

36. Water Absorption and Thickness Swelling

36.1 Procedure

36.1.1 The procedure for determining water absorption after a 24-h immersion shall be the same as that provided in Section 23, Method B on a single 12-in. (305-mm) square specimen (see Note 58), as shown in Fig. 34.

NOTE 58—A 6 by 6-in. (152 by 152-mm) specimen may be used for convenience as an alternative size. The smaller specimen will usually yield slightly higher values for water absorption. In cases where dispute is likely because of amount of water absorbed, the 12-in. square specimens should be used.

36.2 Calculation and Report

36.2.1 The water absorption and average thickness swelling values shall be calculated for each test panel, and reported to the nearest 1 % on a weight basis.

37. Moisture Content and Specific Gravity

37.1 Moisture content and specific gravity of each modulus-of-rupture specimen shall be determined based on the volume at test and oven-dry weight in accordance with Test Methods D4442 and D2395. The average values shall be reported for each test panel to the nearest 0.1 % for moisture content and 0.01 for specific gravity. See Note 59.

NOTE 59—For some specification purposes it may be advantageous to report density instead of specific gravity. When this is so, report the average density in lb/ft³ to the nearest 1 lb/ft³.

38. Report

38.1 The data reported shall include, in addition to the actual test results and data called for specifically under each test, a description of the material, sampling procedure, record of any conditioning or treatment, and notes regarding any specific details that may have a bearing on the test results.

39. Precision and Bias

39.1 Statements on precision and bias have not been developed for these methods. Precision will be estimated in accordance with the interlaboratory test program prescribed by Practice E691.

40. Keywords

40.1 hardboard; medium density fiberboard; oriented strand board; panels; particleboard; particle panel materials; wood; wood-base fiber; wood-base panel

ASTM International takes no position respecting the validity of any patent rights asserted in connection with any item mentioned in this standard. Users of this standard are expressly advised that determination of the validity of any such patent rights, and the risk of infringement of such rights, are entirely their own responsibility.

This standard is subject to revision at any time by the responsible technical committee and must be reviewed every five years and if not revised, either reapproved or withdrawn. Your comments are invited either for revision of this standard or for additional standards and should be addressed to ASTM International Headquarters. Your comments will receive careful consideration at a meeting of the responsible technical committee, which you may attend. If you feel that your comments have not received a fair hearing you should make your views known to the ASTM Committee on Standards, at the address shown below.

This standard is copyrighted by ASTM International, 100 Barr Harbor Drive, PO Box C700, West Conshohocken, PA 19428-2959, United States. Individual reprints (single or multiple copies) of this standard may be obtained by contacting ASTM at the above address or at 610-832-9585 (phone), 610-832-9555 (fax), or service@astm.org (e-mail); or through the ASTM website (www.astm.org). Permission rights to photocopy the standard may also be secured from the Copyright Clearance Center, 222 Rosewood Drive, Danvers, MA 01923, Tel: (978) 646-2600; <http://www.copyright.com/>