



Standard Specification for Sampling and Sample Preparation of Lead and Lead Alloys for Optical Emission Spectrometric or ICP Analysis¹

This standard is issued under the fixed designation B982; the number immediately following the designation indicates the year of original adoption or, in the case of revision, the year of last revision. A number in parentheses indicates the year of last reappraisal. A superscript epsilon (ϵ) indicates an editorial change since the last revision or reappraisal.

^{ε1} NOTE—Section 13.4.2 was corrected editorially in January 2016.

1. Scope

1.1 This specification covers the sampling of lead and lead alloys to obtain a sample suitable for quantitative optical emission spectrochemical analysis. Included are procedures for sample preparation, obtaining representative samples from molten metal, from fabricated, or cast products that can be melted, and from other forms that cannot be melted.

1.2 The values stated in inch-pound units are to be regarded as standard. The values given in parentheses are mathematical conversions to SI units that are provided for information only and are not considered standard.

1.3 *This standard does not purport to address all of the safety concerns, if any, associated with its use. It is the responsibility of the user of this standard to establish appropriate safety and health practices and determine the applicability of regulatory limitations prior to use.*

2. Referenced Documents

2.1 The following documents of the issue in effect on the date of material purchase form a part of this specification to the extent referenced herein.

2.2 *ASTM Standards:*²

E29 [Practice for Using Significant Digits in Test Data to Determine Conformance with Specifications](#)

E37 [Test Methods for Chemical Analysis of Pig Lead](#)

E88 [Practice for Sampling Nonferrous Metals and Alloys in Cast Form for Determination of Chemical Composition](#)

E177 [Practice for Use of the Terms Precision and Bias in ASTM Test Methods](#)

E691 [Practice for Conducting an Interlaboratory Study to](#)

¹ This specification is under the jurisdiction of ASTM Committee B02 on Nonferrous Metals and Alloys and is the direct responsibility of Subcommittee B02.02 on Refined Lead, Tin, Antimony, and Their Alloys.

Current edition approved Oct. 1, 2014. Published April 2015. Originally approved in 2012. Last previous edition approved in 2012 as B982 – 12. DOI: 10.1520/B0982-14E01.

² For referenced ASTM standards, visit the ASTM website, www.astm.org, or contact ASTM Customer Service at service@astm.org. For *Annual Book of ASTM Standards* volume information, refer to the standard's Document Summary page on the ASTM website.

Determine the Precision of a Test Method

3. Significance and Use

3.1 This specification, used in conjunction with an appropriate quantitative optical emission spectrochemical method, is suitable for use in manufacturing control, material or product acceptance, and development and research.

4. Ordering Information

4.1 Orders for refined lead under this specification shall include the following information:

4.1.1 ASTM designation and year of issue,

4.1.2 Quantity (weight),

4.1.3 Name of material (for example, pure lead),

4.1.4 Size and shape (see Section 7),

4.1.5 Grade, and

4.1.6 Certification or test report if specified (Section 13).

5. Materials and Manufacture

5.1 Lead shall be supplied in commercial standard forms or shapes requested by the purchaser in the following grades:

5.1.1 Low bismuth low silver pure lead,

5.1.2 Refined pure lead,

5.1.3 Pure lead, and

5.1.4 Chemical copper lead.

5.1.5 Calcium alloys.

5.1.6 Antimony alloys.

5.2 The grade of lead listed in 5.1.1 – 5.1.6 shall be produced by any smelting and refining process from ore or recycled materials to meet the chemical requirements of this specification.

6. Composition

6.1 This specification shall apply to lead alloys that contain greater than 80 % Pb and meet the requirements of 5.2 for material manufacture.

7. Sizes and Shapes

7.1 Pigs shall weigh up to a nominal 110 lb (50 kg).

7.2 Blocks or hogs shall be square or oblong and weigh up to 2530 lb (1150 kg).

8. Appearance

8.1 The lead shall be reasonably free from surface corrosion, surface cavities, excessive condensation or water, and adhering foreign material.

9. Lot

9.1 All lead of the same type produced and cast at one time shall constitute a lot for chemical analysis. Each pig or block of the lot shall bear a single identifying number that can be related to the manufacturing lot.

10. Sampling for Chemical Analysis

10.1 The sample for chemical analysis shall be selected by one of the following methods:

10.1.1 Test samples taken from the lot during casting applies to all materials.

10.1.2 Test samples taken from the final solidified cast product, for all materials except 5.1.5, calcium alloys.

10.2 *Sampling for Lot Analysis*—The supplier may obtain samples from the lot of molten metal during casting. A sample should be taken at the beginning, middle and end of casting. All or part of these samples may be cast into shapes suitable for use in spectrographic analytical methods. The composite element average for the three grab samples will represent the lot.

10.3 Sampling of Cast Product:

10.3.1 If the lead is in the form of standard pigs (Fig. 1), the sample for chemical analysis shall be taken in accordance with 10.3.3.1, 10.3.3.2, or 10.3.3.3.

10.3.1.1 If the pigs differ in shape from those shown in Fig. 1 or the product is cast into blocks or hogs, the supplier and the purchaser shall agree mutually as to the method to be followed in sampling such shapes. The method of sampling in 10.3 does not apply to alloys that exhibit segregation of alloy agents during casting. This means the calcium aluminum alloys are not to be sampled according to this procedure. The preferred method of determining lot chemistry for calcium aluminum lots is supplier sampling of quick frozen wafers during casting.

10.3.2 *Sampling Pig Lead*—A portion representative of the total shipment shall be selected at random for the final sample. For lots containing at least 100 00 lb (45 400 kg) of pig lead, one pig shall be taken from every 20 000 lb (9080 kg). For smaller lots, a total of five pigs shall be taken.

10.3.3 *Sample Preparation*—Each pig shall be cleaned thoroughly to rid the surface of dirt or adhering foreign material prior to sampling by one of the following methods: sawing, drilling, or melting.

10.3.3.1 *Sawing*—The pigs selected shall be sawed completely through as illustrated in Fig. 1. The sawings from the pigs shall be mixed thoroughly and quartered, and the samples for analysis taken from the mixed material. The sawings must be free of extraneous material introduced from the saw blade. All sawings shall be treated with a strong magnet in order to remove iron introduced by sawing.

10.3.3.2 *Drilling*—The pigs shall be drilled at least halfway through from two opposite sides as illustrated in Fig. 2. A drill

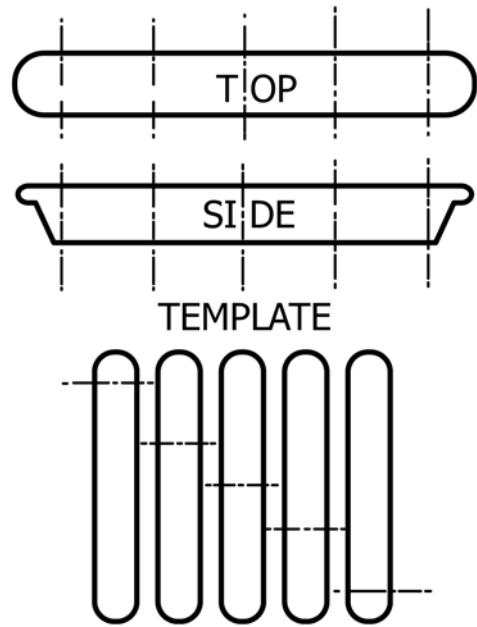

Pigs sampled in sets of five according to template as shown above.

FIG. 1 Method of Sampling Lead by Sawing

of about 1/2 in. (12.7 mm) in diameter shall be used. In drilling, the holes shall be spaced along a diagonal line from one corner of the pig to the other. Holes may be made in a single pig or in each of several pigs placed as illustrated in Fig. 2. The drillings shall be clipped into pieces not over 1/2 in. (12.7 mm) in length, mixed thoroughly, and treated with a strong magnet to remove iron introduced by drilling.

10.3.3.3 *Melting*—Whole pigs, portions of pigs produced by sawing, drillings, or sawings shall be melted in a clean vessel. The melting temperature must not exceed 685°F (363°C) to prevent excessive drossing. The lead must be stirred immediately prior to sampling. The molten lead shall be cast into shapes suitable for use in spectrographic analysis, cast into thin sample bars not to exceed 3/8 in. (9.5 mm) thick for sawing, or granulated by pouring into distilled water and drying the material thoroughly. For sample bars, saw cuts shall be made halfway across the bar from each side and staggered so that they are about 1/2 in. (12.7 mm) apart. The sawings so produced are treated in accordance with 10.3.3.1.

10.3.4 Sample Size:

10.3.4.1 For spectrographic analysis, three samples shall be prepared of a size and shape satisfactory for use by the laboratory at which the analysis is to be made.

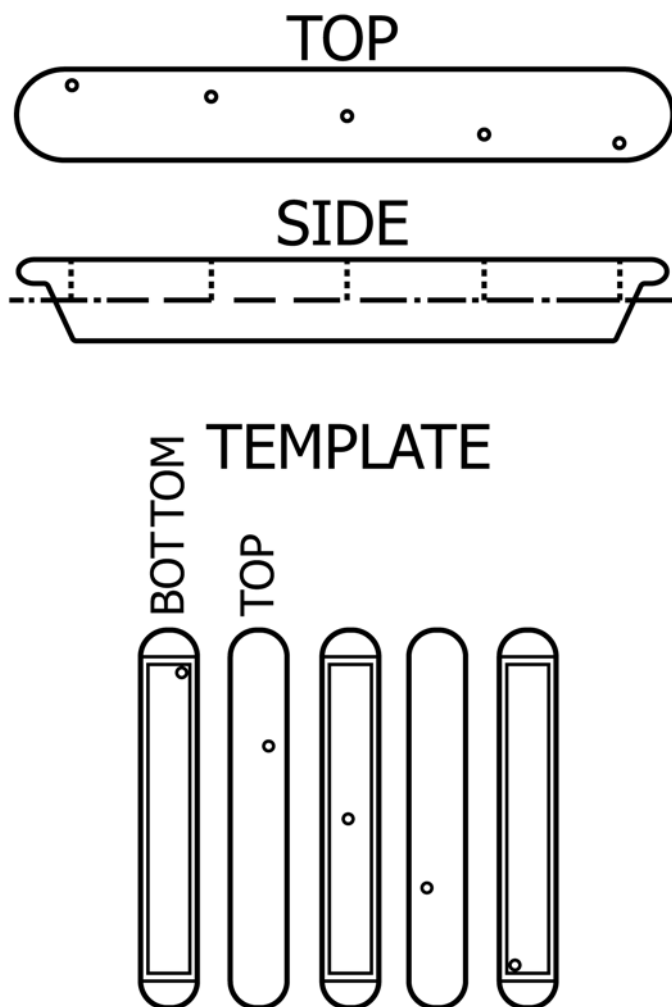

FIG. 2 Method of Sampling Lead by Drilling

10.3.4.2 For wet chemical analysis, each prepared sample (sawings, drillings, or granules) shall weigh at least 600 g.³

10.3.5 Aspects of sampling and sample preparation not specifically covered in this specification shall be carried out in accordance with Practice E88.

11. Apparatus

11.1 *Ladle*, of steel, designed to hold sufficient molten metal to completely fill the sample mold, with a handle of sufficient length to reach into a furnace, trough, pot, or crucible.

NOTE 1—Pure lead metal (Special High Grade) is sampled using a ceramic or graphite ladle, as the solubility of iron in Special High Grade Lead is sufficient to cause a measurable contamination.

11.2 *Sample Molds*, designed to produce homogeneous chillcast specimens having smooth surfaces, free from surface pockets and pores. The specimens shall be representative (in the region to be excited) of the product metal. The samples shall have a spectrochemical response similar to the standards used in preparing the analytical curves. This is ensured by

³ Fox, G. J., "Determination of As, Sb, and Te in Lead and Lead Alloys Using Hydride Generation Atomic Absorption Spectrometry," *Atomic Spectroscopy*, Vol 11, No. 1, January 1990, p. 13.

casting standards and specimens in the same manner. Also, the specimens shall have a repeatability of measurement for major elements from excitation-to-excitation with a relative error of no more than 2%. Several types of molds have been found acceptable.

11.2.1 *Type A, Mass Chill Wafer Mold* (Fig. 3)—This mold produces one diagonally cast wafer without a sprues on the top of the specimen. The mold dimensions are such as to produce wafers approximately 2.5 in. (64 mm) in diameter by 0.5 in. (13 mm) thickness. The mold excluding the handle must be made of mild steel with a thickness in all dimensions of at least 0.5 in. This ensures that samples will cool quickly. The mold is made of steel or cast iron and weigh approximately 1.5 to 2.5 lb (0.45 to 1.1 kg). Wafer specimens have been found to be very homogeneous. If properly prepared, these specimens provide very reliable results with only one burn. However, all wafer specimens must be lathed according to 11.3 before analysis or drilling.

11.2.2 *Other Molds*—Molds of different types, materials, and dimensions may be used provided that the uniformity of the specimens obtained is comparable to the uniformity of specimens obtained from Type A molds. Further, the specimens shall have a spectrochemical response similar to the standards used for preparing the analytical curves.

11.3 *Lathe or Milling Machine*—Lathe should be capable of machining a smooth flat surface, 0.25 in. of material must be removed from the surface.

12. Sampling

12.1 *Molten Metal*—When molten metal is sampled, the temperature shall be well above the point at which any solid phase can be present. Using a clean ladle, push any dross away from the sampling area. Then dip the ladle sideways into the clear area, well below the surface, and stir momentarily. Turn the ladle upright and quickly withdraw. Heating the ladle prevents metal freezing, while obtaining metal well beneath the surface minimizes the danger of inclusion of oxide. Unless the mold is already hot, cast and discard a preliminary specimen.

12.2 *Separate Sampling Ladles and Molds*—Separate sampling molds and ladles are required where cross contamination can occur between alloys.

12.3 *Pouring of Samples*—Remove any excess metal from the ladle, dip it into the molten metal as before, and fill the mold (Section 11). Avoid overfilling the mold. Allow the metal to freeze without jarring. The sample should be visibly solid within 5 s. The cast surfaces of the specimen, upon removal from the mold, shall be free from shrinkage, inclusions, cracks, or roughness.

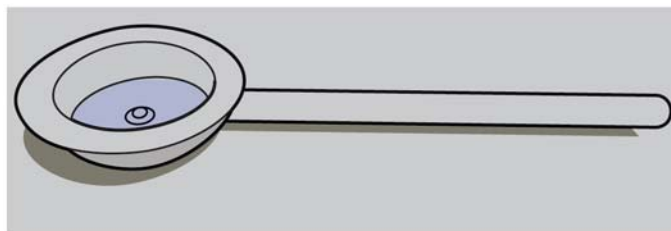

FIG. 3 Wafer Mold

NOTE 2—A change in the temperature profile of the mold, caused by a significant change in the sampling rate, may result in different Mass-Chill-Cast characteristics and poor repeatability. Therefore, it is recommended that the sampling schedule be considered when an analysis program is being developed. Also, experience has shown that wafer specimens are much less sensitive than disk samples to temperature profile changes in the mold.

13. Preparation of Specimens

13.1 *Mass-Chill-Cast Wafers from Type A Mold*—A minimum of ¼ in. must be machined off of the sample, with a lathe compliant to 11.3.

13.2 *Mass-Chill-Cast Specimens from Other Acceptable Molds*—Since a mold of different dimensions may result in a different freezing pattern, each type of mold shall be evaluated to determine the proper area and depth to machine the specimen to represent the true composition of the melt.

13.3 *Direct Excitation Without Casting a Specimen*—If the procedure outlined in Section 12 cannot be followed, only approximate analyses can be made. The specimen shall be massive enough to prevent undue heating and shall have a flat surface suitable for excitation. Further, standards having a similar spectrochemical response shall be available. On sheet or plate specimens, machine off about 0.03 in. (0.8 mm) or one-fourth of the thickness, whichever is smaller. On thicker specimens, machine at least 0.05 in. (1.3 mm) below the original surface. Choose the location, depth, and number of areas to be analyzed to provide a representative analysis of the product.

13.4 *Sample Preparation for ICP or AA Analysis:*

13.4.1 Taking the sample into solution:

1.) In a 250 mL beaker make up a solution of; 3 g Tartaric acid, 25 mL 30 % H₂O₂. Bring to 100 mL level with distilled H₂O. Heat solution until Tartaric is dissolved.

2.) In a 250 mL beaker, put your weighed out sample (normally use 0.2 g), add 30 mL HCL, 30 mL HNO₃. Place beaker on heat at 300°C for 5 min.

3.) Let the sample boil for about 5 min. then add about 20 mL of the Tartaric solution. (Pay close attention when doing this as it tends to try and boil over.) Let boil again for about 5 min. and add about 10 mL distilled H₂O. At 10 min. increments add 20 mL Tartaric and distilled H₂O, as needed. About 30 min. into the process add about 5 mL each of the HCL and HNO₃. When clear, remove the sample and let cool to 90°F. At this temperature dilute up to 200 mL with distilled water and run the sample on the ICP or AA.

13.4.2 *Matrix Matching*—It is recommended that a known primary lead sample is run through the sample preparation and is run on an ICP or AA to verify that the method is correct and to rule out spectral interference and matrix effects. These samples can be obtained through Brammer, NIST or ASTM.

14. Marking and Special Requirements

14.1 A brand, by which the supplier can be identified, shall be cast or marked legibly upon each pig, block, or hog. In addition, other markings shall identify the material by type and lot number.

14.2 (Any) special marking, color code, and other quality requirements not covered by this specification shall be agreed upon between the supplier and the purchaser.

15. Inspection

15.1 Inspection of the material shall be agreed upon between the purchaser and the supplier as part of the purchase contract.

16. Rejection and Rehearing

16.1 Material that fails to conform to the requirements of this specification may be rejected. Rejection should be reported to the supplier promptly and in writing. In case of dissatisfaction with the results of the test, the supplier may make claim for a rehearing.

16.2 Rejection shall be considered as follows:

16.2.1 Variation of weight, quantity, dimensions, or workmanship.

16.2.2 Chemical composition.

16.2.2.1 In case of dispute, the material shall be sampled in the presence of both parties in accordance with 10.3.

16.2.2.2 The resulting sample (at least 1800 g) shall be mixed and separated into three equal parts, each of which shall be placed in a sealed package, one for the supplier, one for the purchaser, and one for the umpire if necessary, and analyzed in accordance with Test Methods E37.

16.2.2.3 Sub surface cavities, containing excessive water.

16.3 When the lead metal satisfies the chemical and physical requirements of this specification, it shall not be condemned for defects in manufacturing or for defects of alloys or products in which it is used.

17. Precision and Bias⁴

17.1 The precision of this specification is based on an interlaboratory study of ASTM B982, Specification for Sampling and Sample Preparation of Lead and Lead Alloys for Optical Emission Spectrometric or ICP Analysis, conducted in 2010. Eleven laboratories participated in this study. Each of the labs was asked to report five replicate test results on a total of four materials. Every “test result” reported represents a single determination or measurement. Practice E691 was followed for the design and analysis of the data.⁴

17.1.1 *Repeatability Limit (r)*—Two test results obtained within one laboratory shall be judged not equivalent if they differ by more than the “r” value for that material; “r” is the interval representing the critical difference between two test results for the same material, obtained by the same operator using the same equipment on the same day in the same laboratory.

17.1.1.1 Repeatability limits are listed in Table 1.

17.1.2 *Reproducibility Limit (R)*—Two test results shall be judged not equivalent if they differ by more than the “R” value for that material; “R” is the interval representing the critical

⁴ Supporting data have been filed at ASTM International Headquarters and may be obtained by requesting Research Report RR:B02-1000. Contact ASTM Customer Service at service@astm.org.

TABLE 1 Analyte Concentration

Sample	Average ^A \bar{X}	Repeatability Standard Deviation s_r	Reproducibility Standard Deviation S_R	Repeatability Limit r	Reproducibility Limit R
Ca	0.07223	0.00080	0.00326	0.00223	0.00912
Sn	0.80496	0.00684	0.01923	0.01915	0.05384
Al	0.01296	0.00030	0.00127	0.00083	0.00355
Ag	0.00072	0.00003	0.00011	0.00008	0.00031

^A The average of the laboratories' calculated averages.

TABLE 2 Analyte Concentration

Sample	Average ^A \bar{X}	Repeatability Standard Deviation s_r	Reproducibility Standard Deviation S_R	Repeatability Limit r	Reproducibility Limit R
Sn	0.2013	0.0017	0.0118	0.0049	0.0329
Ag	0.0035	0.0000	0.0004	0.0001	0.0012
Cu	0.0517	0.0007	0.0032	0.0021	0.0088
Bi	0.0119	0.0002	0.0013	0.0005	0.0036
Ni	0.0001	0.0000	0.0001	0.0000	0.0001
As	0.1569	0.0028	0.0018	0.0077	0.0329
Sb	4.1193	0.0672	0.1033	0.1882	0.2892
Se	0.0165	0.0006	0.0023	0.0017	0.0066
S	0.0140	0.0014	0.0141	0.0039	0.0396

^A The average of the laboratories' calculated averages.

difference between two test results for the same material, obtained by different operators using different equipment in different laboratories.

17.1.2.1 Reproducibility limits are listed in **Table 1**.

17.1.3 The above terms (repeatability limit and reproducibility limit) are used as specified in Practice **E177**.

17.1.4 Any judgment in accordance with **17.1.1** and **17.1.2** would have an approximate 95 % probability of being correct.

17.2 *Bias*—At the time of the study, there was no accepted reference material suitable for determining the bias for this test method, therefore no statement on bias is being made.

17.3 The precision statement was determined through statistical examination of 692 results, from nine laboratories, reporting up to seven replicate analyses, on a total of four different materials.

17.3.1 To judge the equivalency of two test results, it is recommended to choose the material closest in characteristics to the test specimen.

18. Precision and Bias⁵

18.1 The precision of this specification is based on an interlaboratory study of ASTM B982, Specification for Sampling and Sample Preparation of Lead and Lead Alloys for Optical Emission Spectrometric or ICP Analysis, conducted in 2010. Each of ten laboratories tested a single material for nine elements. Every “test result” represents an individual

determination, and all participants were asked to report five test results for each element measured. Except for the testing of only a single type of material, Practice **E691** was followed for the study design and analysis of the data.

18.1.1 *Repeatability Limit (r)*—Two test results obtained within one laboratory shall be judged not equivalent if they differ by more than the “*r*” value for that material; “*r*” is the interval representing the critical difference between two test results for the same material, obtained by the same operator using the same equipment on the same day in the same laboratory.

18.1.1.1 Repeatability limits are listed in **Table 2**.

18.1.2 *Reproducibility Limit (R)*—Two test results shall be judged not equivalent if they differ by more than the “*R*” value for that material; “*R*” is the interval representing the critical difference between two test results for the same material, obtained by different operators using different equipment in different laboratories.

18.1.2.1 Reproducibility limits are listed in **Table 2**.

18.1.3 The above terms (repeatability limit and reproducibility limit) are used as specified in Practice **E177**.

18.1.4 Any judgment in accordance with statements in **18.1.1** and **18.1.2** would have an approximate 95 % probability of being correct.

18.2 *Bias*—At the time of the study, there was no accepted reference material suitable for determining the bias for this test method, therefore no statement on bias is being made.

18.3 The precision statement was determined through statistical examination of 400 results, for a total of nine elements, submitted by ten laboratories, on a single material.

⁵ Supporting data have been filed at ASTM International Headquarters and may be obtained by requesting Research Report RR:B02-1001. Contact ASTM Customer Service at service@astm.org.

19. Keywords

19.1 chemical-copper lead; lead; lead metal; optical emissions; pure lead; refined pure lead; sampling; spectrochemical analysis

ASTM International takes no position respecting the validity of any patent rights asserted in connection with any item mentioned in this standard. Users of this standard are expressly advised that determination of the validity of any such patent rights, and the risk of infringement of such rights, are entirely their own responsibility.

This standard is subject to revision at any time by the responsible technical committee and must be reviewed every five years and if not revised, either reapproved or withdrawn. Your comments are invited either for revision of this standard or for additional standards and should be addressed to ASTM International Headquarters. Your comments will receive careful consideration at a meeting of the responsible technical committee, which you may attend. If you feel that your comments have not received a fair hearing you should make your views known to the ASTM Committee on Standards, at the address shown below.

This standard is copyrighted by ASTM International, 100 Barr Harbor Drive, PO Box C700, West Conshohocken, PA 19428-2959, United States. Individual reprints (single or multiple copies) of this standard may be obtained by contacting ASTM at the above address or at 610-832-9585 (phone), 610-832-9555 (fax), or service@astm.org (e-mail); or through the ASTM website (www.astm.org). Permission rights to photocopy the standard may also be secured from the Copyright Clearance Center, 222 Rosewood Drive, Danvers, MA 01923, Tel: (978) 646-2600; <http://www.copyright.com/>