



Standard Specification for Seamless and Welded Titanium and Titanium Alloy Condenser and Heat Exchanger Tubes with Enhanced Surface for Improved Heat Transfer¹

This standard is issued under the fixed designation B891; the number immediately following the designation indicates the year of original adoption or, in the case of revision, the year of last revision. A number in parentheses indicates the year of last reapproval. A superscript epsilon (ϵ) indicates an editorial change since the last revision or reapproval.

1. Scope*

1.1 This specification² covers seamless and welded titanium and titanium alloy tubing on which at least part of the external or internal surface has been enhanced by cold forming for improved heat transfer. The tubes are used in surface condensers, evaporators, heat exchangers, coils, and similar heat transfer apparatus in diameters up to and including 1 in. (25.4 mm). The base tube wall thickness is typically at least 0.049 in. average, but lighter gauge may be negotiated with the manufacturer.

1.2 Tubing purchased to this specification will typically be inserted through close-fitting holes in tubesheets, baffles, or support plates spaced along the tube length such as defined in the Tubular Exchanger Manufacturer's Association (TEMA) Standard.³ The tube ends will also be expanded, and may then be welded. Tube may also be bent to form U-tubes or be coiled or otherwise formed, although tight radii may require unenhanced length for the bends.

1.3 The values stated in inch-pound units are to be regarded as standard. The values given in parentheses are mathematical conversions to SI units that are provided for information only and are not considered standard.

1.4 The following precautionary statement pertains to the test method portion only: Section 8, 9, 10 and S1 of this specification: *This standard does not purport to address all of the safety concerns, if any, associated with its use. It is the responsibility of the user of this standard to establish appropriate safety and health practices and determine the applicability of regulatory limitations prior to use.*

¹ This specification is under the jurisdiction of ASTM Committee B10 on Reactive and Refractory Metals and Alloys and is the direct responsibility of Subcommittee B10.01 on Titanium.

Current edition approved March 1, 2012. Published March 2012. Originally approved in 1998. Last previous edition approved in 2004 as B891 – (2004). DOI: 10.1520/B0891-12.

² For ASME Boiler and Pressure Vessel Code applications, see related Specification SB-_____ in Section II of that Code.

³ Available from Tubular Exchanger Manufacturers Association, Inc. 25 North Broadway Tarrytown, NY 10591, www.tema.org.

2. Referenced Documents

2.1 *ASTM Standards*:⁴

A1047/A1047M Test Method for Pneumatic Leak Testing of Tubing

B338 Specification for Seamless and Welded Titanium and Titanium Alloy Tubes for Condensers and Heat Exchangers

E426 Practice for Electromagnetic (Eddy-Current) Examination of Seamless and Welded Tubular Products, Titanium, Austenitic Stainless Steel and Similar Alloys

E1316 Terminology for Nondestructive Examinations

3. Terminology

3.1 *Definitions of Terms Specific to This Standard:*

3.1.1 *base tube, n*—the seamless or welded tube conforming to Specification B338 prior to enhancing.

3.1.2 *finished tube, n*—the tube following enhancement and any heat treatment, forming, or other processing specified.

3.1.3 *enhanced tube or section, n*—all or sections of tube length that have been mechanically worked inside, outside, or both, to produce increased surface area for improved heat transfer.

3.1.4 *finned section, n*—sections of tube exterior length that have been mechanically worked to produce increased surface area for improved heat transfer; see Table 1 for nomenclature of finning details.

3.1.5 *ribbed section, n*—sections of tube interior length that have been mechanically worked to produce increased surface area for improved heat transfer; see Table 1 for nomenclature of ribbing details.

3.1.6 *plain ends, n*—tube ends that have not been enhanced to allow for tube expansion for which properties are essentially identical to the base tube.

3.1.7 *land, n*—section of finished tube where the exterior and the interior surfaces have not been enhanced, to provide

⁴ For referenced ASTM standards, visit the ASTM website, www.astm.org, or contact ASTM Customer Service at service@astm.org. For *Annual Book of ASTM Standards* volume information, refer to the standard's Document Summary page on the ASTM website.

*A Summary of Changes section appears at the end of this standard

TABLE 1 ENHANCED TUBE NOMENCLATURE

| | |
|----|--|
| D | Outside Diameter of Base Tube |
| Di | Inside Diameter of Base Tube |
| dr | Root Diameter of Finned Section – Outside of Tube |
| do | Outside Diameter of Enhanced Section – Outside of Tube |
| di | Inside Diameter of Enhanced Section – Inside of Tube |
| W | Wall Thickness of Base Tube |
| Wf | Wall Thickness in Enhanced Section |
| Fh | Height of Fin – Outside of Tube |
| Fm | Mean Fin Thickness – Finned Section Outside of Tube |
| P | Mean Rib Pitch – Enhanced Section Inside of Tube |
| Rh | Height of Rib – Enhanced Section Inside of Tube |
| Ha | Rib Helix Angle – Enhanced Section Inside of Tube |
| Tt | Transition Taper |

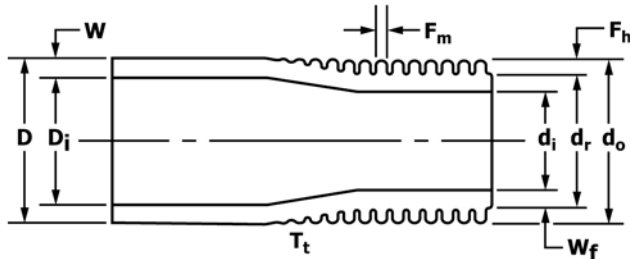

FIG. 1 Outside Finning Only

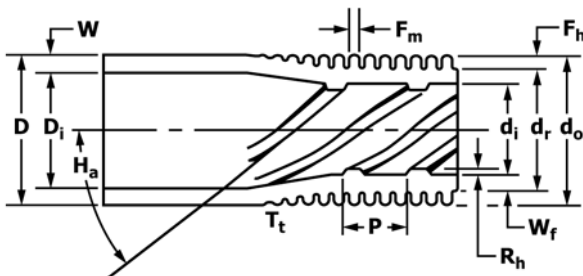

FIG. 2 Outside Finning and Inside Ribbing

better support where passing through baffles, or for sections of tube that will subsequently be formed as U-bends; normally neither inside nor outside surfaces are enhanced in the land.

3.2 Condition (of finished tubes):

3.2.1 *as-enhanced tube, n*—tube which is supplied with no thermal treatment following enhancement.

3.2.2 *annealed tube, n*—tube where at least the enhanced length has been heat treated such that a recrystallized microstructure results for improved ductility for forming of coils or U-bends. Refer to S2.

3.2.3 *stress relieved tube, n*—U-tube where at least the bent section has been heat treated after bending for dimensional stability of the bends. Refer to 7.2.

3.2.4 *thermally oxidized tube, n*—tube where the entire length has been heat treated specifically for the purpose of enhancing or thickening the surface oxide. Refer to S3.

3.3 Lot Definition—A lot shall consist of finished tube from the same base tube heat, enhanced in the same manner and nominal dimensions, and subsequently heat treated using the same resistance heating parameters, in the same furnace charge, or if in a continuous furnace with continuous temperature monitoring and control within a 24 h time period.

4. Ordering Information

4.1 Purchase orders for tubes described in this specification should include the following to describe the tubes adequately.

4.1.1 ASTM Specification B891 designation and year of issue.

4.1.2 ASTM Specification B338 grade number.

4.1.3 If either welded or seamless is required for base tube.

4.1.4 Quantity (number of pieces) and the total tube length to be supplied under the purchase order.

4.1.5 Base tube dimensions; diameter, wall thickness (average or minimum wall thickness must be specified), tube length(s).

4.1.6 Enhancement: configuration of finned surfaces (fins per unit length, fin height, wall thickness under fin, etc. – refer to Fig. 1), configuration of ribbed surfaces (pitch, height, thickness of rib – refer to Fig. 2), length of plain ends, location and length of lands (refer to Figs. 3 and 4).

4.1.7 Dimensions: length of straight tubes (refer to Fig. 3), bend radii and leg lengths to tangent of U-bends (refer to Fig. 4).

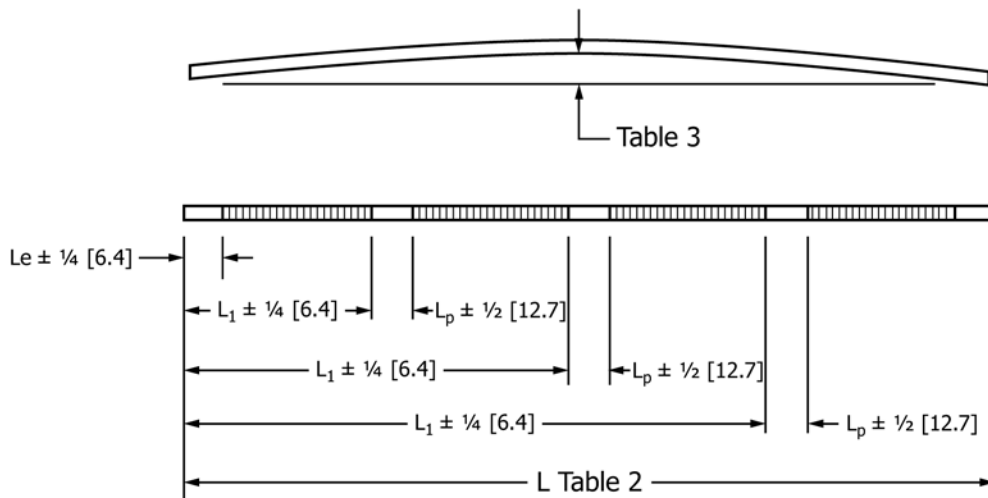

FIG. 3 Straight Tube Dimensional Tolerances

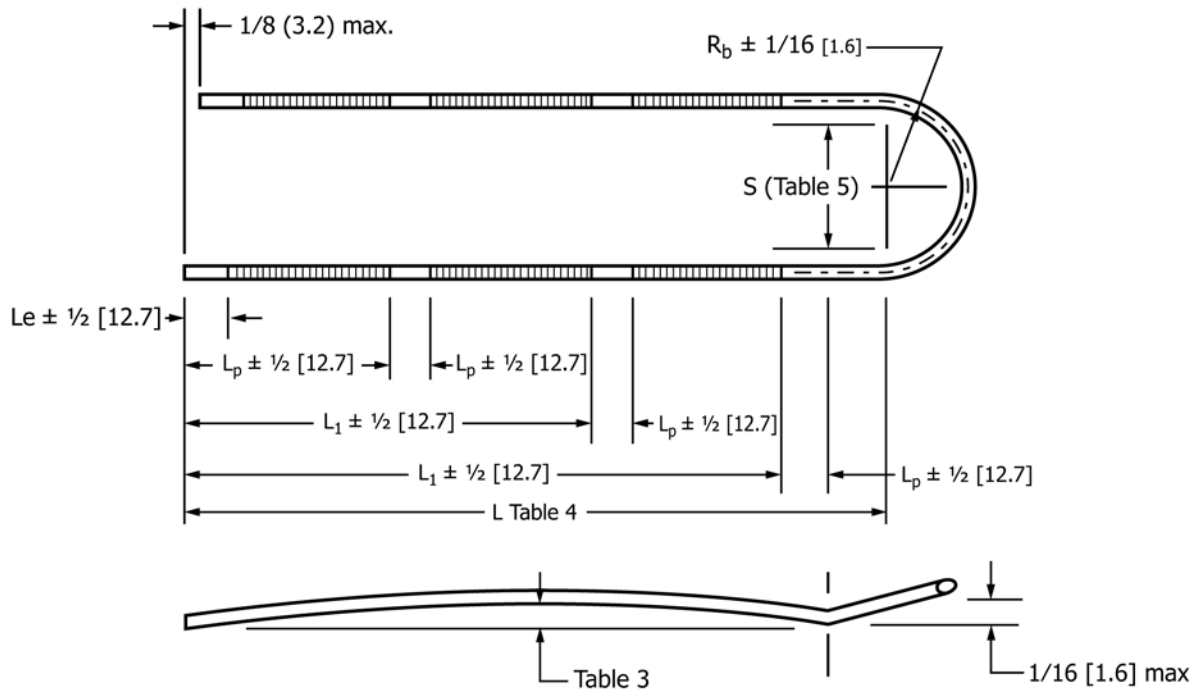

FIG. 4 U-Tube Dimensional Tolerances

4.1.8 Condition: heat treatment, (annealing, stress relieving, or thermal oxidation) requirements other than the standard as-enhanced condition (refer to 3.2, Section 7, and S2 and S3).

4.1.9 Nondestructive test requirements other than standard eddy current test (refer to Section 10).

4.1.10 Pressure test requirements other than standard pneumatic air under water or pressure differential tests (refer to Section 10).

4.1.11 Packaging, if other than manufacturer's standard (refer to Section 16).

4.1.12 Supplementary Requirements made a part of the purchase order.

5. General Requirements

5.1 Tubes described by this specification shall be furnished with plain ends.

5.2 Enhanced sections of the tube shall be supplied in the cold worked condition produced by the enhancing operation unless specified otherwise in the purchase order (refer to Supplementary Requirements S2 and S3.)

5.3 The tubes shall be able to stand properly conducted expansion and bending without showing cracks or other flaws.

6. Materials and Manufacture

6.1 The enhanced tubes shall be manufactured from annealed seamless or stress relieved or annealed welded base tubes that conform to the requirements of Specification B338.

6.2 Enhanced sections shall be produced by cold forming.

6.3 Plain ends and lands shall not be cold worked during the enhancing operations.

6.4 The following titanium grades are considered suitable for enhancing: Grade 1 (11, 17, 27), 2, (7, 16, 26), 2H (7H, 16H, 26H), and 3.

6.4.1 Enhancing of other grades may be considered by negotiation with the manufacturer.

7. Condition and/or Heat Treatment

7.1 Straight tubes and the straight sections of U-tubes shall be supplied in the as-enhanced condition as described in 3.2.1, unless specified otherwise by the purchaser (see Supplementary Requirements S2 and S3).

7.2 U-bends shall be stress relieved in the bent length and at least 1 in. (25.4 mm) of material beyond the tangent of each leg using parameters sufficient to maintain dimensional stability of the bend.

7.2.1 U-bends shall include a minimum of 2 in. (50.8 mm) land or unfinned length located on each straight leg beyond the tangent of the bend to allow for clamping surface when electric resistance method is used for heat treatment.

7.2.2 Stress relieving shall be conducted in air or in a protective inert gas atmosphere such that the operation does not result in excessive surface oxidation. Surface oxidation indicated by an iridescent straw to dark blue surface color is normal following stress in relieving in air. Matte gray, or loose white or yellow scale is unacceptable.

8. Chemical Composition

8.1 The composition of the titanium or titanium alloy shall conform to the chemical requirements for the grade specified as listed in Specification B338.

9. Tensile Requirements

9.1 The base tube prior to the enhancing operation shall conform to the tensile properties and other applicable requirements of Specification **B338** for the grade specified.

10. Nondestructive, Pressure, and Other Tests

10.1 Nondestructive, pressure, and other tests other than those made mandatory in **10.2** or **10.3** shall be specified in the purchase order.

10.2 *Eddy Current Test*—Each tube in the finished condition, except for bending if that is required, shall be subjected to an eddy current test in accordance with Practice **E426** by passing it through an encircling coil designed to test the entire cross section of the tube.

10.2.1 The reference standard tube used to calibrate the eddy current test equipment shall be sound and of the same grade, condition, nominal dimensions, and enhanced configuration as the lot of tubes to be tested on a production basis. Drill four holes not larger than 0.031 in. (0.787 mm) in diameter radially through the enhanced wall in each of four successive planes at 0, 90, 180 and 270°. Use EDM or a suitable drill and jig to guide the drill, taking care to avoid distortion of the adjacent fins. Locate one hole in the weld for welded material. Artificial discontinuities shall be spaced at least 16 in. (406 mm) apart to provide signal resolution adequate for interpretation. Discard the reference standard and replace when erroneous signals are produced from mechanical, metallurgical or other damage to the reference tube.

10.2.2 Adjust the eddy current test unit to obtain an optimum signal-to-noise ratio with the minimum sensitivity required to detect all four artificial defects in the reference standard on a repeatable basis. Equipment adjustments and tube speed maintained during calibration shall be the same for production tubes.

10.2.3 Set aside tubes showing an eddy current indication in excess of any signal obtained from artificial defects in the reference standard and subject them to retest or rejection.

10.2.4 Tubes causing irrelevant signals because of moisture, debris and like effects shall be considered to conform, should they not cause output signals beyond acceptable limits when retested. Tubes causing irrelevant signals because of visible and identifiable handling marks shall be considered to conform, provided the wall thickness in the enhanced and unenhanced areas is not less than the minimum specified.

10.2.5 Tubes causing relevant signals because of injurious defects that reduce the wall thickness below the minimum specified shall be rejected. If, after retest and examination, no source for the reject signal can be discerned, the tube shall be rejected.

10.3 *Pneumatic Pressure Test*—Each tube in the finished condition, except for bending if that is required, shall be subjected to a pneumatic pressure test. Each tube shall withstand a minimum internal pressure of 250 psi (1.72 MPa) for a minimum of 5 s without showing evidence of leakage. The test method used shall permit easy detection of any leakage by placing the tube underwater or by using the pressure differential method as defined in Test Method **A1047/A1047M**. Any evidence of leakage shall be cause for rejection of that tube.

10.4 *Hydrostatic Pressure Test:*

10.4.1 Hydrostatic test of straight tube is not required unless Supplementary Requirement S1 is made part of the purchase order.

10.4.2 Hydrostatic test of U-bend tube is required. Testing shall be completed for each U-tube. Testing shall be conducted in accordance with Supplementary Requirement S1.

10.4.3 Hydrostatic testing shall be conducted after all required enhancing, bending, and heat treatment is completed.

11. Permissible Variations in Dimensions

11.1 *Diameter:*

11.1.1 The outside diameter of plain ends and lands shall not vary by more than the amount in **Table 2**, as measured by “go” and “no go” ring gauges. The dimensions of the ring gauges shall be as described in **11.1.3** and **11.1.4**.

11.1.2 The diameter over the enhanced sections shall not exceed the diameter of the plain sections involved, as determined by a “go” ring gauge unless otherwise specified.

11.1.3 The inside diameter dimension of the “go” ring gauge shall be equal to the nominal tube diameter, plus the plus tolerance from **Table 2**, plus 0.002 in. (0.051 mm). The length of the “go” ring gauge shall be 1 in. (25.4 mm) minimum.

11.1.4 The inside diameter dimension of the “no go” ring or snap-on gauge shall be equal to the nominal tube diameter minus the minus tolerance from **Table 2**. The length of the “no go” ring gauge shall be 1 in. (25.4 mm) minimum.

11.1.5 Permissible variations from the specified outside diameter in the bent portion of the U-tube for bend radius $R = 2 \times D$ or greater, neither the major nor minor diameter of the tube shall deviate from the nominal diameter prior to bending by more than 10 %.

11.1.6 Permissible variations from the specified outside diameter in the bent portion of the U-tube for bend radius less than $R = 2 \times D$ shall be negotiated between the manufacturer and the purchaser.

11.2 *Wall Thickness:*

11.2.1 Wall thickness in plain end and lands (except in bends) shall conform to the requirements of Specification **B338** for average or minimum wall as specified.

TABLE 2 Permissible Variations in Outside Dimensions and Wall Thickness Based on Individual Measurements

| Outside Diameter, in. (mm) | Diameter Tolerance in. (mm) ^A | Permissible Variations ^A in Wall Thickness, t, % | Permissible Variations ^A in Minimum Wall Thickness, t, % |
|----------------------------|---|--|---|
| Under 1 (25.4), excl | ±0.004 (±0.102) | ±10 | ±20, -0 |
| 1 (25.4) | ±0.005 (±0.127) | ±10 | ±20, -0 |

^A These permissible variations in outside diameter apply only to tubes as finished at the mill before subsequent swaging, expanding, bending, polishing or other fabricating operations.

11.2.2 Permissible variations from the specified average wall thickness in enhanced sections (W_f in Fig. 2 and Fig. 1) are $\pm 10\%$ (Table 2).

11.2.3 Permissible variations from the specified minimum wall thickness in enhanced sections (W_f in Fig. 2 and Fig. 1) are $\pm 20\%$, -0% (Table 2).

11.2.4 Permissible variations from the specified wall thickness in U-bends shall not be less than value determined by the equation:

$$t_f = (4 \times R \times T) / (4 \times R + D) \quad (1)$$

where:

- t_f = wall thickness after bending, in. (mm),
- T = minimum wall thickness of 10.2.1, 10.2.2, 10.2.3, in. (mm),
- R = centerline bend radius, in. (mm), and
- D = nominal outside tube diameter, in. (mm).

11.3 *Squareness of Cut*—The angle of cut of the end of any tube shall not depart from square by more than 0.016 in. (0.4 mm).

11.4 *Dimensional Tolerances for Straight Tubes*—(See Table 3 and Fig. 3.)

11.4.1 *Straight Lengths*—The maximum permissible variations for lengths (L) 24 ft (7.3 m) and shorter shall be $+\frac{1}{8}$ in. (3.2 mm), -0 ; for lengths longer than 24 ft (7.3 m), an additional over tolerance of $+\frac{1}{8}$ in. (3.2 mm) for each 10 ft (3 m), or fraction thereof, shall be permitted up to a maximum of $+\frac{1}{2}$ in. (12.7 mm).

11.4.2 The length of the plain ends (L_e) for straight tubes, as measured from the tube end to the first tool impression, shall not be less than specified, but may exceed the specified value by $\frac{1}{2}$ in. (12.7 mm).

11.4.3 The distance from the end of the tube to the start of intermediate lands, (L_1) shall not vary by more than $\pm \frac{1}{4}$ in. (6.2 mm).

11.4.4 The length of lands (from the last tool mark to the first tool mark) shall not vary by more than $\pm \frac{1}{4}$ in. (6.2 mm).

11.5 *Dimensional Tolerances for U-Bends*—(See Tables 4-6 and Fig. 4.)

11.5.1 *Tube Legs*—The length of the tube legs (L), as measured at the point of tangency to the end of the tube leg shall not be less than specified, nor exceed the specified length by the amount given in Table 5 and Fig. 4.

11.5.2 The difference in lengths of the tube legs shall not be greater than $\frac{1}{8}$ in. (3.2 mm).

11.5.3 The length of the plain ends (L_e), for U-tubes, as measured from the tube end to the first tool impression, shall not be less than specified, nor exceed the specified value by more than 1 in. (25.4 mm).

TABLE 3 Length Tolerances

| Specified Length, ft (m) | Tolerance, in. (mm) |
|-----------------------------------|---------------------------|
| Up to 24 (7.3), incl | $+\frac{1}{8}$ (3.2) |
| Over 24 to 34 (7.3 to 10.4), incl | $+\frac{1}{4}$ (6.4) |
| Over 34 to 44 (10.4 to 13.4) incl | $+\frac{3}{8}$ (9.5) |
| Over 44 (13.4) | $+\frac{1}{2}$ (12.7) max |

TABLE 4 Straightness Tolerances

| Length, ft (m) | Maximum Curvature (Depth of Arc) |
|-----------------------------------|--|
| Over 3 to 6 (0.91 to 1.83), incl | $\frac{1}{8}$ in. (3.2 mm) |
| Over 6 to 8 (1.83 to 2.44), incl | $\frac{3}{16}$ in. (4.8 mm) |
| Over 8 to 10 (2.44 to 3.05), incl | $\frac{1}{4}$ in. (6.4 mm) |
| Over 10 (3.05) | $\frac{1}{4}$ in./any 10 ft (2.1 mm/m) |

TABLE 5 U-Tube Leg Length Tolerance

| Leg Length (L), ft (m) | Plus Tolerance, in. (mm) |
|---------------------------------|--------------------------|
| Up to 20 (6), incl | $\frac{1}{8}$ (3.2) |
| Over 20 to 30 (6 to 9), incl | $\frac{5}{32}$ (4.0) |
| Over 30 to 40 (9 to 12.2), incl | $\frac{3}{16}$ (4.8) |

TABLE 6 U-Tube Leg Spacing (S) Tolerance

| Bend Radius, R_b , in. (mm) | Tolerance on S, in. (mm) |
|--|--------------------------------|
| Up to 18 (457), incl | $\pm \frac{1}{16}$ (1.6) |
| Over 18 to 30 (over 457 to 762), incl | $\pm \frac{3}{32}$ (2.4) |
| Over 30 to 36 (over 1220 to 914), incl | $\pm \frac{1}{8}$ (3.2) |
| Over 36 (762) | by agreement with manufacturer |

11.5.4 The distance from the end of the tube to the start of intermediate lands, (L_1) shall not vary by more than $\pm \frac{1}{2}$ in. (± 12.7 mm).

11.5.5 The length of lands L_p (from the last tool mark to the first tool mark) shall not vary by more than $\pm \frac{1}{2}$ in. (12.7 mm).

11.5.6 The leg spacing measured between the points of tangency of the bend (S) shall not vary from the value ($2 R_b - \text{specified tube outside diameter}$) by more than $\pm \frac{1}{16}$ in. (± 1.6 mm), where R_b is the specified centerline of the bend radius.

11.5.7 The bent portion of the U-tube shall be substantially uniform in curvature, and not to deviate by more than $\pm \frac{1}{16}$ in. (± 1.6 mm) from the nominal centerline radius (R_b).

11.5.8 Permissible deviation of the bend from the plane established by the straight lengths of the tubes near the points of tangency shall not exceed $\frac{1}{16}$ in. (1.6 mm).

11.6 In the event of dispute, the length parameters of the tubes shall be measured at a temperature of $68 \pm 10^\circ\text{F}$ ($20 \pm 6^\circ\text{C}$).

11.7 *Straightness*—The tube shall be free of bends or kinks, and the maximum uniform bow in straight tubes or in the straight portion of U-tubes shall not exceed the values given in Table 4 for Fig. 3 or Fig. 4.

11.8 *Minimum Bend Radii for Enhanced Tube:*

11.8.1 Tube with a nominal bend radius less than the tube diameters listed in the following table may be supplied with no fins in the area of the bend at the discretion of the manufacturer.

| Grade | Bend Radius |
|---------------------------------------|---------------------------|
| Grades 1, 11, 17, 27 | 4 times the tube diameter |
| Grades 2, 2H, 7, 7H, 16, 16H, 26, 26H | 4 times the tube diameter |
| Grade 3 | 6 times the tube diameter |

12. Workmanship, Finish, and Appearance

12.1 Finished tubes shall be clean and free of foreign material, shall have smooth ends free of burrs, and shall be free

of injurious external and internal imperfections. Minor defects may be removed, provided the dimensional tolerances of Section 11 are not exceeded.

12.1.1 A slight amount of surface oxide thickening indicated by a straw, light brown, or light blue iridescent surface color is acceptable for tubes with no heat treatment after enhancement. Surface oxidation indicated by a straw, light brown, light blue, or dark blue surface color is acceptable for tubes where annealing after enhancement is specified.

13. Inspection

13.1 The manufacturer shall inspect and make the necessary tests to verify that the tubes furnished conform to the requirements of the customer purchase order and to the requirements of this specification.

13.2 When specified in the purchase order, the manufacturer shall notify the purchaser of scheduled testing in a timely manner, but not less than 48 h prior to scheduled testing, so that the purchaser may have his inspector present to witness any part of the tests that may be desired. If the purchaser's representative is not present at the time agreed upon for the testing, the manufacturer shall consider the requirement for purchaser's inspection at place of manufacture to be waived.

13.3 Should the purchaser additionally elect to perform his own inspection, the manufacturer shall afford the inspector all reasonable facilities to determine that the tubes being furnished conform to the requirements of the customer purchase order and to the requirements of this specification.

13.3.1 All tests and inspections shall be made at the place of manufacture prior to shipment unless specified otherwise in the purchase order, and shall be so conducted as not to interfere with the operation of the facility.

14. Rejection

14.1 Any rejection based on tests made in accordance with this specification, and those allowed by Specification B338, shall be reported to the manufacturer, promptly and in writing.

14.2 Material that fails in the process of installation shall be set aside and the manufacturer notified for mutual evaluation of suitability of the material.

14.3 Disposition of such material shall be a matter of agreement between the manufacturer and the purchaser.

15. Certification and Reporting

15.1 The manufacturer shall supply at least one copy of the report certifying that the material supplied has been manufactured, inspected, sampled, and tested in accordance with the requirements of this specification and that the results of chemical analysis, tensile, and other tests meet the requirements of this specification for the grade specified. The report shall include results of all chemical analysis, tensile tests, and all other tests required by the specification.

15.2 *Base Tube*—Reports shall include at least: the base tube material designation (B338); the grade number; the base tube manufacturer's name; whether base tube was welded or seamless; diameter; wall thickness (average or minimum); and material heat number. Information for each heat shall include: chemical composition; product analysis (when specified); tensile test results; flattening, reverse flattening, and flaring test results; ultrasonic, eddy current and either pneumatic or hydrostatic test results (including test pressure, psi). Information may be transferred from the original manufacturer's test reports or copies of the original manufacturer's test report may be supplied.

15.3 *Finished Tube Test Reports* shall include at least this specification number, customer name; the base tube heat number, customer purchase order number; product description, drawing or part number; quantity; eddy current test results; pneumatic test results (including test pressure, psi); and results of any other checks or testing required by the purchase order or Supplementary Requirements specified in the purchase order.

16. Packaging and Package Marking

16.1 The tube shall be packaged in accordance with the manufacturer's standard practice which at minimum shall satisfy 16.1.1 – 16.1.3, 16.2, and 16.3 unless otherwise agreed upon between the manufacturer and the purchaser and so stated in the purchase order.

16.1.1 All tubing shall be packaged and blocked in such a manner as to prevent damage in ordinary handling and transportation. The boxes shall be constructed in such a manner that no nails, staples, screws, or similar fasteners are required to close and secure the box after the tubes have been placed in the box. The box shall be lined with plastic sheet or vapor barrier materials so as to prevent contamination of the tube during handling, transportation, and storage.

16.1.2 Straight tubes shall be arranged in boxes in a regular pattern with tubes in the same relative position from end to end. Tubes may touch along their length with no intermediate separation material.

16.1.3 U-bend tubes shall be arranged in boxes so that the smaller radius bends may be removed without disturbing larger radius bends. Individual tubes shall be blocked and braced in a manner that holds the nominal shape of the bend and adequately supports the length.

16.2 Tubes for an item number shall be boxed together.

16.3 Each shipping unit shall be legibly marked with the name of the supplier, name of the customer, ship to address, purchase order number, alloy designation, size or part number, tube length and number of pieces.

17. Keywords

17.1 condenser; enhanced tube; evaporator; finned tube; heat exchanger; heat transfer; integral fins; ribbed tube; seamless; titanium; titanium alloy; tube; U-bend; welded

SUPPLEMENTARY REQUIREMENTS

The following supplementary requirements become a part of the specification when specified in the purchase order or contract.

S1. Hydrostatic Pressure Test

S1.1 Each straight tube after enhancing or U-tube tube after bending and heat treatment shall be subjected to a hydrostatic pressure test. Each tube shall withstand, without showing bulges, leaks or other defects, an internal hydrostatic pressure that will produce in the tube wall a stress of 50 % of the minimum specified yield strength at room temperature. This pressure shall be determined by the equation:

$$P = (S * E * W_f) / (d_r / 2 - 0.4 * W_f)$$

where:

- P = minimum hydrostatic test pressure, psi (or MPa),
 S = one half the minimum yield strength, psi (or MPa), (for Gr. 1 (11, 17, 27) 10 000 psi; for Gr. 2 (7, 16, 26) 20 000 psi; for Gr. 2H (7H, 16H, 26H) 20 000 psi; for Gr. 3, 27 500 psi).
 W_f = wall under fin thickness, in. (or mm),
 d_r = fin root diameter, in. (or mm),
 E = 0.85 welded base tube, and
 E = 1.0 seamless base tube.

S1.2 The maximum hydrostatic test pressure shall not exceed 2500 psi (17.2 MPa) for sizes 1 in. (25.4 mm) and under. Hydrostatic pressure shall be maintained for not less than 5 s.

S1.3 When requested by the purchaser and so stated in the order, tubes shall be tested to one and one half times the specified working pressure, provided the fiber stress corresponding to those test pressures does not exceed one half the minimum specified yield strength of the material as determined by the equation in S1.1.

S1.4 When one and one half times the working pressure exceeds 2500 psi (17.2 MPa), the hydrostatic test pressure shall be a matter of agreement between the manufacturer and purchaser.

S1.5 Hydrostatic testing shall be conducted after all required enhancing and heat treatment is completed.

S2. Annealing for Subsequent Forming

S2.1 The enhanced length of straight tubes intended for bending for U-tubes, forming, or coiling shall be annealed.

S2.2 The time and temperature shall be such that a recrystallized microstructure results in enhanced areas.

S2.3 A test sample of the same material with the same heat treatment shall be sectioned and metallurgically examined to verify that an equiaxed annealed microstructure was achieved.

S2.4 The manufacturer shall certify and report that the test sample was adequately annealed as described in 3.2.2.

S2.5 Annealing shall be conducted in air or in an inert gas such that surface oxidation resulting from the operation does not result in surface oxide greater than indicated by an iridescent silver, straw, light blue or dark blue color. A matte gray oxide or any oxide with loose scale shall be rejected.

S2.5.1 Treatment may be accomplished by electric resistance heating.

S2.5.1.1 Where resistance heating is used, the manufacturer shall anneal a test sample of the same grade, size and wall thickness, enhanced in the same manner, and using the same electrical and time parameters.

S2.5.3 Treatment may be accomplished in an inert atmosphere (argon) furnace or in an air furnace environment utilizing electric heating or in a propane or natural gas fired furnace adjusted to create slightly oxidizing conditions. No other fuels shall be utilized.

S2.5.3.1 Where furnace heating is used, the manufacturer shall anneal a test sample of the same grade, size and wall thickness, enhanced in the same manner, and annealed at the same time in the same furnace (see lot definition 3.3).

S3. Thermal Oxide Enhancement for Corrosion Resistance

S3.1 Tube surfaces shall be thermally oxidized to increase the thickness of the surface oxide.

S3.2.1 Treatment may be accomplished by electric resistance heating selected for the purpose of enhancing or thickening the surface oxide.

S3.2.2 Treatment may be accomplished in an air furnace environment utilizing electric heating or in a propane or natural gas fired furnace adjusted to create slightly oxidizing conditions. No other fuels shall be utilized.

S3.3 Surface oxidation indicated by an iridescent dark blue surface color is normal following this treatment. Matte gray, or loose white or yellow scale is unacceptable.

SUMMARY OF CHANGES

Committee B10 has identified the location of selected changes to this standard since the last issue (B891 - 98 (2004)) that may impact the use of this standard. (Approved March 1, 2012.)

- (1) Added definitions in Section 3.
- (2) Made annealed or stress relieved a standard requirement for base tubes, 6.1.
- (3) Made as-enhanced the standard condition for straight tubes or straight sections of U-tubes, Section 7.
- (4) Made stress relieved the standard condition for the bent portion of U-tubes, 7.2.
- (5) Added requirements and dimensional tolerances for plain ends and lands, Section 11 and Fig. 3 and Fig. 4.
- (6) Added requirements and dimensional tolerances for U-bends, Section 11 and Fig. 4.
- (7) Made eddy current NDT and pneumatic pressure tests standard, Section 10.
- (8) Revised wording of Certification and Reporting to conform to other titanium specifications, and added detail of what is to be included in test reports, 15.1.
- (9) Added Supplementary Requirements S1 to S3.

ASTM International takes no position respecting the validity of any patent rights asserted in connection with any item mentioned in this standard. Users of this standard are expressly advised that determination of the validity of any such patent rights, and the risk of infringement of such rights, are entirely their own responsibility.

This standard is subject to revision at any time by the responsible technical committee and must be reviewed every five years and if not revised, either reapproved or withdrawn. Your comments are invited either for revision of this standard or for additional standards and should be addressed to ASTM International Headquarters. Your comments will receive careful consideration at a meeting of the responsible technical committee, which you may attend. If you feel that your comments have not received a fair hearing you should make your views known to the ASTM Committee on Standards, at the address shown below.

This standard is copyrighted by ASTM International, 100 Barr Harbor Drive, PO Box C700, West Conshohocken, PA 19428-2959, United States. Individual reprints (single or multiple copies) of this standard may be obtained by contacting ASTM at the above address or at 610-832-9585 (phone), 610-832-9555 (fax), or service@astm.org (e-mail); or through the ASTM website (www.astm.org). Permission rights to photocopy the standard may also be secured from the Copyright Clearance Center, 222 Rosewood Drive, Danvers, MA 01923, Tel: (978) 646-2600; <http://www.copyright.com/>