



Standard Test Method for Shear Testing of Thin Aluminum Alloy Products¹

This standard is issued under the fixed designation B831; the number immediately following the designation indicates the year of original adoption or, in the case of revision, the year of last revision. A number in parentheses indicates the year of last reapproval. A superscript epsilon (ϵ) indicates an editorial change since the last revision or reapproval.

1. Scope*

1.1 This test method covers single shear testing of thin wrought and cast aluminum alloy products to determine shear ultimate strengths. It is intended for products that are too thin to be tested according to Test Method B769.

1.2 The values stated in inch-pound units are to be regarded as standard. The values given in parentheses are mathematical conversions to SI units that are provided for information only and are not considered standard.

1.3 *This standard does not purport to address all of the safety concerns, if any, associated with its use. It is the responsibility of the user of this standard to establish appropriate safety and health practices and determine the applicability of regulatory limitations prior to use.*

2. Referenced Documents

2.1 The following documents of the issue in effect on the date of material purchase, unless otherwise noted, form a part of this specification to the extent referenced herein:

2.2 *ASTM Standards:*²

B565 Test Method for Shear Testing of Aluminum and Aluminum-Alloy Rivets and Cold-Heading Wire and Rods

B769 Test Method for Shear Testing of Aluminum Alloys

E4 Practices for Force Verification of Testing Machines

E6 Terminology Relating to Methods of Mechanical Testing

E2208 Guide for Evaluating Non-Contacting Optical Strain Measurement Systems

3. Terminology

3.1 *Definitions*—The definitions of terms relating to shear testing in Terminology E6 are applicable to the terms used in this test method.

¹ This test method is under the jurisdiction of ASTM Committee B07 on Light Metals and Alloys and is the direct responsibility of Subcommittee B07.05 on Testing.

Current edition approved May 1, 2014. Published July 2014. Originally approved in 1993. Last previous edition approved in 2011 as B831 – 11. DOI: 10.1520/B0831-14.

² For referenced ASTM standards, visit the ASTM website, www.astm.org, or contact ASTM Customer Service at service@astm.org. For *Annual Book of ASTM Standards* volume information, refer to the standard's Document Summary page on the ASTM website.

4. Summary of Test Method

4.1 This test method consists of subjecting a full thickness or machined rectangular test specimen to single shear force to failure in a test fixture using a tension testing machine. The shear strength is calculated from the maximum force required to fracture the specimen.

5. Significance and Use

5.1 The intent of this test method is to provide a means of measuring the ultimate shear strength of thin aluminum alloy wrought and cast products. It is recognized that the loading conditions developed by this test method, and by most others, are not ideal in that they do not strictly satisfy the definitions of pure shear. However, rarely do pure shear conditions exist in structures.

NOTE 1—Results from this test method are not interchangeable with results from Test Methods B565 and B769. Shear strengths obtained by this test method have been shown to differ from values determined with other methods.³

6. Apparatus

6.1 *Testing Machines*—The testing machines shall conform to the requirements of Practice E4. The maximum force used to determine the shear strength shall be within the verified force range of the testing machine as defined in Practice E4.

6.2 *Loading Device:*

6.2.1 The device for applying force to the specimen from the testing machine shall be a clevis of the type shown in Fig. 1 and shall be made of a hardened steel.

7. Test Specimens

7.1 The specimen size shall be 1.5 in. (38.1 mm) wide by 4.5 in. (114 mm) long. The specimen geometry is shown in Fig. 2. The specimen thickness shall be the full product thickness for a product thickness of 0.250 in. (6.35 mm) or less. For a product thickness greater than 0.250 in. (6.35 mm), the specimen shall be machined to a thickness of 0.250 in. (6.35 mm) by machining equal amounts from each side of the

³ Davies, R. E., and Kaufman, J. G., "Effects of Test Method and Specimen Orientation on Shear Strengths of Aluminum Alloys," *Proceedings, ASTM*, Vol 64, 1964.

*A Summary of Changes section appears at the end of this standard

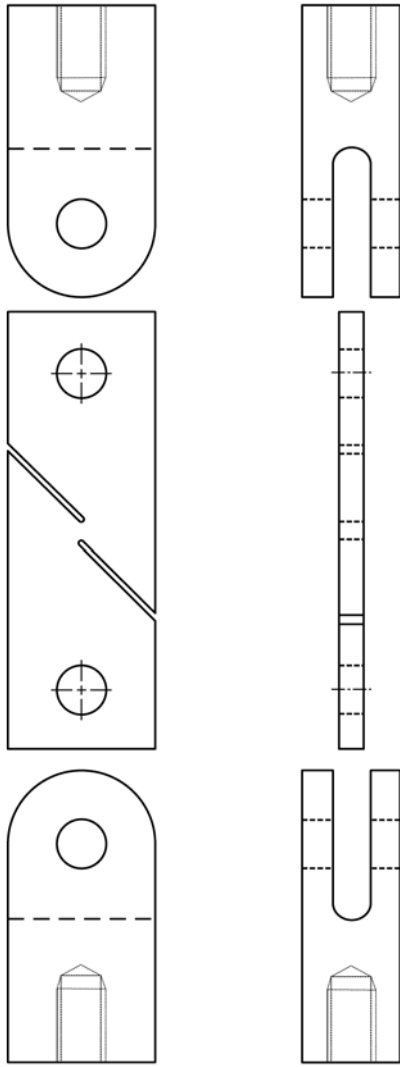

FIG. 1 Slotted Single Shear Test Fixture

8. Specimen Orientation and Direction

8.1 The shear strength of wrought aluminum materials usually depends on the specimen orientation and the direction in which the load is applied relative to the grain flow in the specimen.³ The specimen orientation and the loading direction should be identified by the following systems.

8.1.1 The reference directions for rectangular shapes are indicated in Fig. 3. These are suitable for sheet, plate, extrusions, forgings, and other shapes having nonsymmetrical grain flow.

8.2 The two-letter code is used in Fig. 3 to describe the specimen orientations and loading directions. The first letter designates the normal to the expected shear plane. The second letter designates the direction of force application or expected fracture direction. The most commonly used specimen orientations and loading directions are T-L and L-T for in-plane shear strength of thin products. This orientation code is identical to that used for cylindrical shear specimens in Test Method B769.

NOTE 2—These orientation codes are analogous to those used for fracture specimens if the first letter is interpreted as the normal to the fracture plane and the second letter is the direction of fracture.

NOTE 3—Typically, cast aluminum products do not exhibit the directionality of wrought products; therefore, the orientation codes are not applicable to castings.

9. Procedure

9.1 *Measurement of Specimens*—Measure the applicable dimensions designated in 7.3 and calculate the cross-sectional area by multiplying the two dimensions ($A = t \cdot L$).

9.2 *Testing*—Mount the specimen in the test fixture as shown in Fig. 1. The specimen should not be restrained by clamping of the load pin area during the test.

9.2.1 When assembling the loading train (clevises and their attachments to the testing machine), take care to minimize eccentricity of loading due to misalignments external to the clevises. To obtain satisfactory alignment, keep the centerline of the upper and lower loading rods coincident within 0.03 in. (0.76 mm) during the test.

9.2.2 The cross head speed of the testing machine shall not exceed 0.75 in./min (19.1 mm/min) and the shear stress rate shall not exceed 100 ksi/min (689 MPa/min) on the cross-section. The machine crosshead speed setting should not be adjusted during the test.

9.2.3 Determine the maximum force P_{\max} to fracture the specimen.

10. Calculation

10.1 Calculate the shear strength from the maximum force as follows:

$$S = \frac{P_{\max}}{A} \quad (1)$$

where:

S = shear strength, psi (MPa),
 P_{\max} = maximum force, lbf (N), and
 A = cross-sectional area (thickness t times distance between slots, L), in.² (mm²).

product. The minimum specimen thickness that can be reasonably tested will be dictated by the material's ability to resist buckling around the pin hole area during testing.

7.2 The test area to be sheared shall be centered within 0.001 in. (0.025 mm) of the load line of the specimen.

7.3 Measure and record the thickness (t) and length (L) of the area to be sheared. Measurements shall be made as follows:

7.3.1 Measurement of the specimen thickness shall be made at a location between the two slots machined into the specimen. Measurement of the length of the shear area shall be between the ends of the slots machined into the specimen, Fig. 2. For dimensions 0.200 in. (5.1 mm) and over, measure to the nearest 0.001 in. (0.025 mm). For dimensions less than 0.200 in. (5.1 mm) and not less than 0.100 in. (2.5 mm), measure to the nearest 0.0005 in. (0.013 mm). For dimensions less than 0.100 in. (2.5 mm), measure to the nearest 0.0001 in. (0.0025 mm).

7.4 All machined surfaces in the test area shall have a surface finish of 32 μ in. (0.80 μ m) R_a or less.

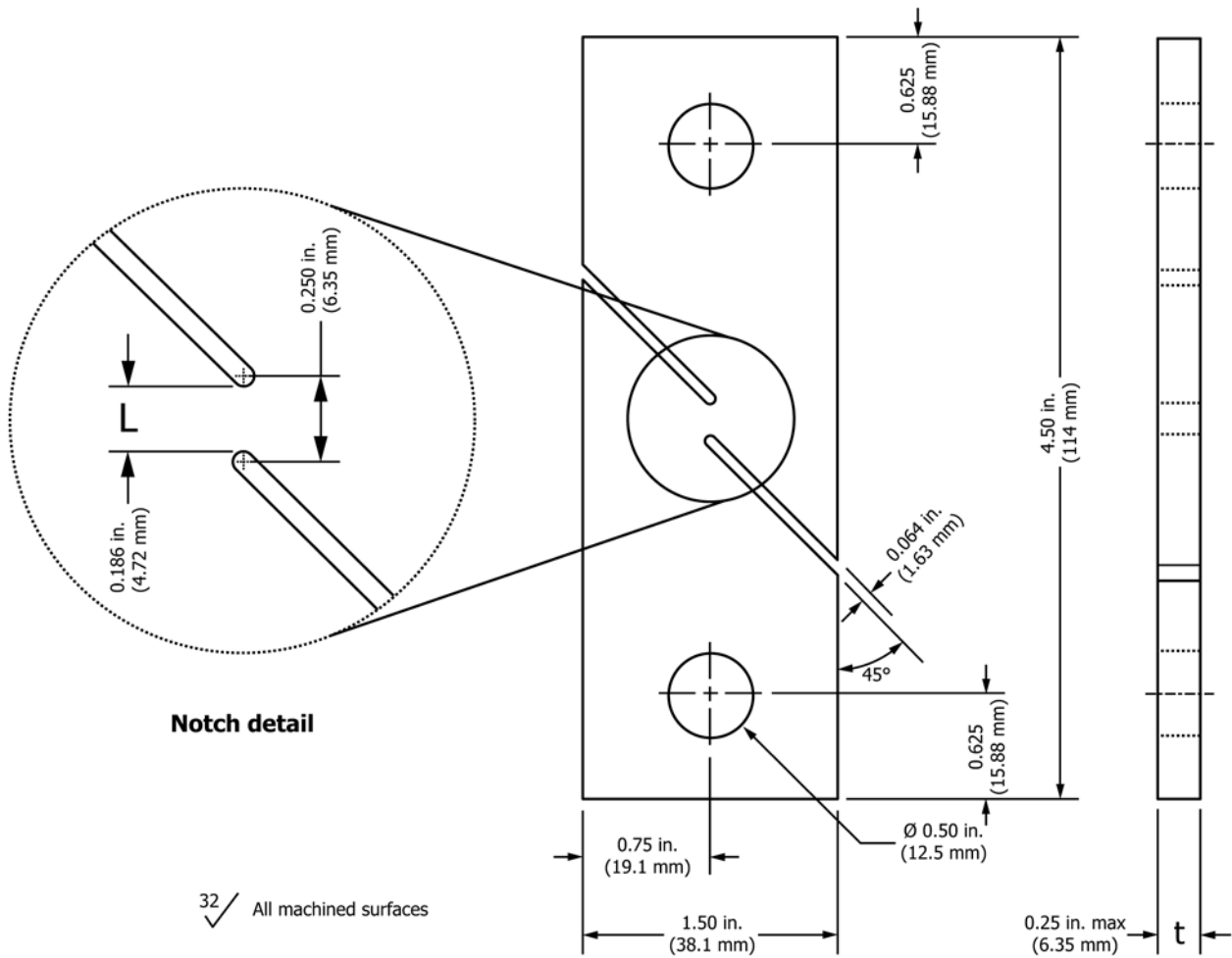

FIG. 2 Slotted Single Shear Test Specimen

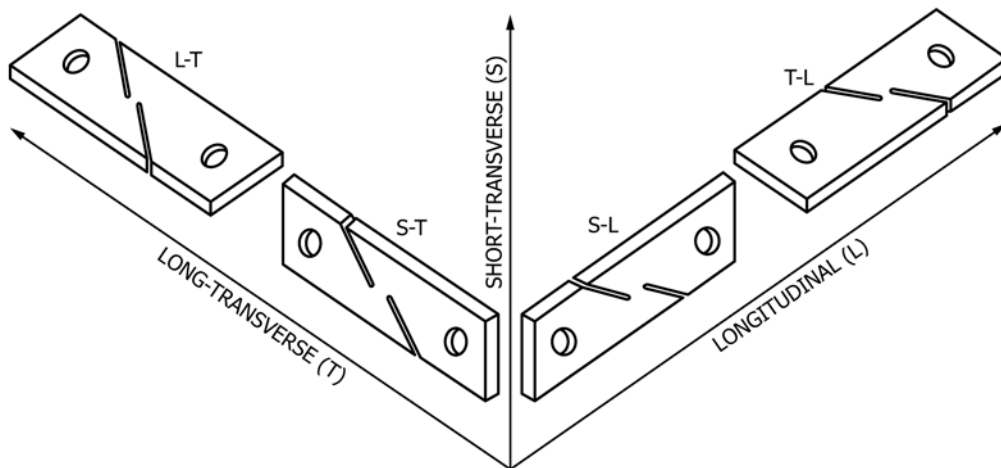

FIG. 3 Grain Orientations and Specimen Orientation Codes for Slotted Single Shear Specimens from Rectangular Shapes

11. Report

11.1 Report the following information:

11.1.1 ASTM method of shear test,

NOTE 4—Since the test method significantly influences the test results, it is essential that the ASTM method be referenced.

11.1.2 Material and sample identification,

11.1.3 Specimen dimensions, in in. (mm),

11.1.4 Specimen orientation code,

11.1.5 Maximum force, in lbf (N),

11.1.6 Shear strength, in psi (MPa), and

11.1.7 Test temperature, if other than room temperature, in °F (°C).

12. Precision and Bias

12.1 The precision and bias of this test method needs to be established. Subcommittee B7.05 is developing the precision and bias statements for this test method.

13. Keywords

13.1 aluminum; mechanical test; shear; strength

APPENDIX

X1. AN ADVANCED METHOD OF DETERMINING SHEAR STRESS-SHEAR STRAIN BEHAVIOR USING DIGITAL IMAGE CORRELATION (DIC) AND A MODIFIED SPECIMEN DESIGN

X1.1 Two-dimensional digital image correlation system using one digital camera shall be used to measure shear strain development within the shear zone during the test. The DIC system shall conform to the requirements in Guide E2208-02.

X1.2 Measuring shear stress-shear strain curves at large strains requires the modified specimen⁴ shown in Fig. X1.1. This modified sample geometry ensures that the zone undergoes only simple shear; it also prevents end rotation of the shear zone.

X1.3 A flat and matte speckle pattern shall be applied to one side of the shear zone prior to the test. First, a white color pattern shall be applied with full coverage as a background and then the black color shall be superimposed on the background as dispersed speckles. Proper lighting (for example, polarized light) shall be used to ensure the full shear zone be viewed in the digital camera.

X1.4 Shear strain is measured as the change of an angle of 90° in the undeformed state to a new angle in the deformed state.

X1.5 The shear stress, τ shall be calculated as:

$$\tau = \frac{P}{Lt_0} \tag{X1.1}$$

⁴ Kang, J., Wilkinson, D. S., Wu, P.D., Bruhis, M., Jain, M., Embury, J. D., Mishra, R.K., "Constitutive Behavior of AA5754 Sheet Materials at Large Strains," *ASME Journal of Engineering Materials and Technology*, Vol. 130: 031004-1-5, 2008.

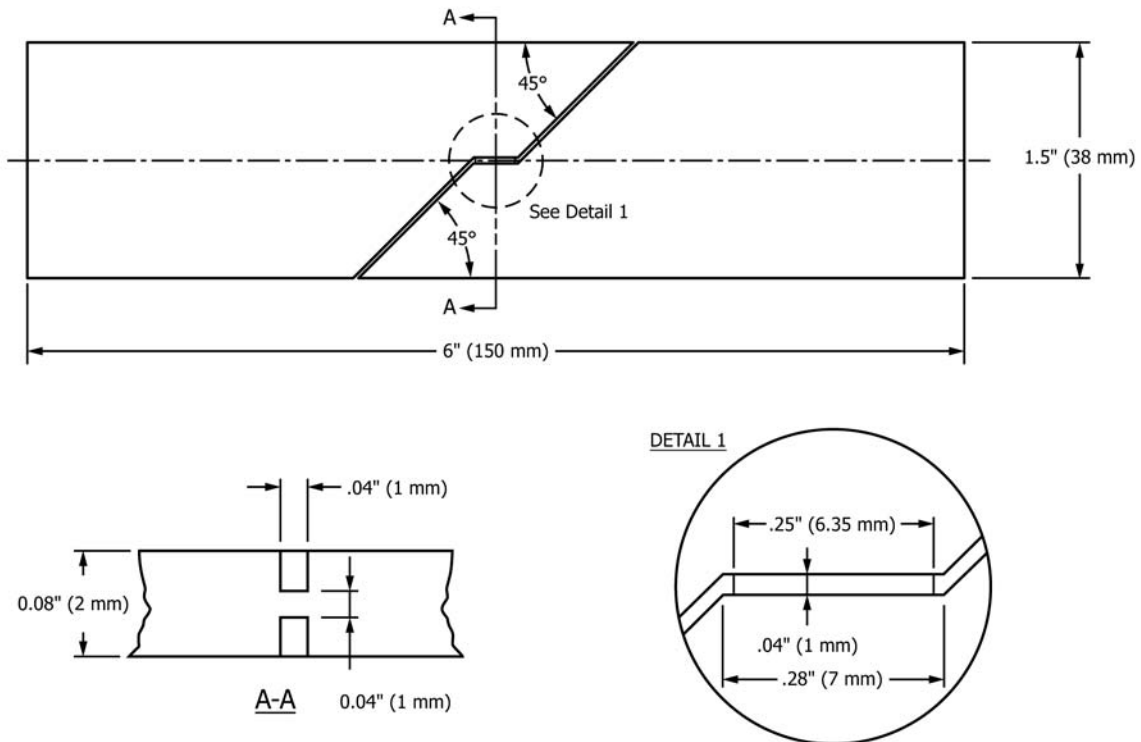

FIG. X1.1 Modified Shear Specimen

where:

- P = the instantaneous applied force,
 L = the length of the shear zone (for example, 0.25 in. (6.35 mm) in Fig. X1.1), and
 t_0 = the thickness of the shear zone (for example, 0.04 in. (1 mm) in Fig. X1.1).

X1.5.1 From the DIC measurements, the average shear strain and/or shear angle over the shear zone shall be reported. If only shear angle, α is reported, then the shear strain, γ is calculated as:

$$\gamma = \tan(\alpha) \quad (X1.2)$$

SUMMARY OF CHANGES

Committee B07 has identified the location of selected changes to this standard since the last issue (B831–11) that may impact the use of this standard. (Approved May 1, 2014)

(1) Added Appendix.

ASTM International takes no position respecting the validity of any patent rights asserted in connection with any item mentioned in this standard. Users of this standard are expressly advised that determination of the validity of any such patent rights, and the risk of infringement of such rights, are entirely their own responsibility.

This standard is subject to revision at any time by the responsible technical committee and must be reviewed every five years and if not revised, either reapproved or withdrawn. Your comments are invited either for revision of this standard or for additional standards and should be addressed to ASTM International Headquarters. Your comments will receive careful consideration at a meeting of the responsible technical committee, which you may attend. If you feel that your comments have not received a fair hearing you should make your views known to the ASTM Committee on Standards, at the address shown below.

This standard is copyrighted by ASTM International, 100 Barr Harbor Drive, PO Box C700, West Conshohocken, PA 19428-2959, United States. Individual reprints (single or multiple copies) of this standard may be obtained by contacting ASTM at the above address or at 610-832-9585 (phone), 610-832-9555 (fax), or service@astm.org (e-mail); or through the ASTM website (www.astm.org). Permission rights to photocopy the standard may also be secured from the Copyright Clearance Center, 222 Rosewood Drive, Danvers, MA 01923, Tel: (978) 646-2600; <http://www.copyright.com/>