



Standard Test Method for Bend Test for Determining the Formability of Copper and Copper Alloy Strip¹

This standard is issued under the fixed designation B820; the number immediately following the designation indicates the year of original adoption or, in the case of revision, the year of last revision. A number in parentheses indicates the year of last reapproval. A superscript epsilon (ϵ) indicates an editorial change since the last revision or reapproval.

1. Scope*

1.1 This test method describes the technique of bend testing copper and copper alloy strip samples to determine product formability or the ability to resist cracking when forming a bend around a specific radius. The criterion for failure is the occurrence of cracks on the outer radius of curvature (convex).

1.2 This bend test is limited to strip from 0.003 to and including 0.031 in. thick (0.076 to and including 0.79 mm).

1.3 The size of the forming radii used in this test shall be 0.005 to and including 0.250 in. (0.127 to and including 6.35 mm).

1.4 *Units*—Values stated in inch-pound units are to be regarded as standard. The values given in parentheses are mathematical conversions to SI units which are provided for information only and are not considered standard.

1.5 *This standard does not purport to address all of the safety concerns, if any, associated with its use. It is the responsibility of the user of this standard to establish appropriate safety and health practices and determine the applicability of regulatory limitations prior to use.*

2. Referenced Documents

2.1 *ASTM Standards:*²

- B846 Terminology for Copper and Copper Alloys
- B950 Guide for Editorial Procedures and Form of Product Specifications for Copper and Copper Alloys
- E6 Terminology Relating to Methods of Mechanical Testing
- E290 Test Methods for Bend Testing of Material for Ductility

3. Terminology

3.1 For definitions of terms related to copper and copper alloys, refer to Terminology B846.

¹ This test method is under the jurisdiction of ASTM Committee B05 on Copper and Copper Alloys and is the direct responsibility of Subcommittee B05.06 on Methods of Test.

Current edition approved Sept. 1, 2014. Published September 2014. Originally approved in 1992. Last previous edition approved in 2014 as B820 – 14. DOI: 10.1520/B0820-14A.

² For referenced ASTM standards, visit the ASTM website, www.astm.org, or contact ASTM Customer Service at service@astm.org. For *Annual Book of ASTM Standards* volume information, refer to the standard's Document Summary page on the ASTM website.

3.2 For definitions of terms related to mechanical testing, refer to Terminology E6.

3.3 *Description of Terms Specific to This Standard:*

3.3.1 *bend, longitudinal (or good way bend)*—a bend with an axis perpendicular to the direction of rolling, drawing or extrusion (see Fig. 1).

3.3.2 *bend, transverse (or bad way bend)*—a bend with an axis on a plane parallel to the direction of rolling, drawing or extrusion (see Fig. 1).

NOTE 1—The usage of these two terms is consistent with Test Methods E290.

4. Summary of Test Method

4.1 The bend test is made by applying a force transversely to the length of the specimen in the portion being bent, usually at mid-length. The 90° bending forces are applied through an arrangement illustrated in Fig. 2, while 180° bending forces are applied through an arrangement illustrated in Fig. 3. When complete fracture does not occur, the convex surface of the specimen is examined for cracks. In general, the test using a 180° bend angle is a more severe test than the test using a 90° bend angle.

5. Significance and Use

5.1 This bend test provides information as to the formability or the ability of copper and copper alloy strip to resist cracking when being formed.

5.2 This test method can be used as a quality control tool to determine if material will form to a given radius.

5.3 This test method is also useful in research and development to provide data for use in selecting a spring material that will safely form to the geometry of a given part.

5.4 The results are suitable for direct application in design and manufacturing, only when all factors such as the geometry of the part, punch and die design, lubrication, stamping speed, and other material properties are known.

6. Apparatus

6.1 Various devices are suitable for 90° or 180° bend testing. The apparatus shall provide these features:

*A Summary of Changes section appears at the end of this standard

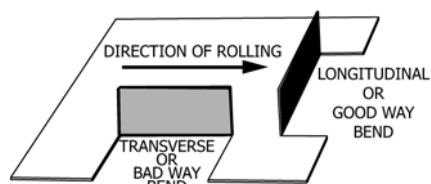

FIG. 1 Direction of Bending

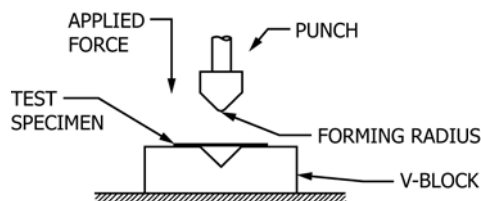

FIG. 2 V-Block and Punch for 90° Bend Test

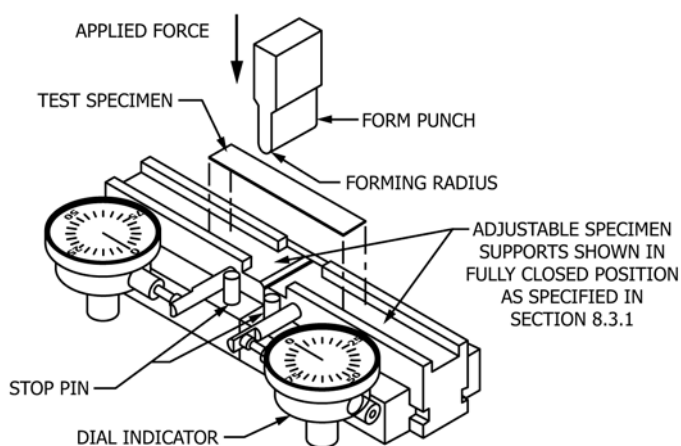

FIG. 3 Fixture for 180° Bend Test

6.1.1 *90° Bend Test Fixture*—An illustration of this test fixture is shown in Fig. 2. A specimen rests on a pair of pins, rollers, or radiused flat supports; a pin, mandrel, or 90° V-block punch of a given bend radius for applying the bending force directly at the mid-length.

6.1.2 *180° Bend Test Fixture*—An illustration of this test fixture is shown in Fig. 3. A specimen rests on a pair of pins, rollers, or radiused flat supports; a pin, mandrel, or 180° punch of a given bend radius for applying the bending force directly at the mid-length. Dial indicators with a precision of 0.0005 in. (0.013 mm) or better are necessary to accurately position the two supports.

6.1.2.1 To prevent breaking the punch, it is recommended not to use a radius smaller than ½ the thickness of the material being tested and in no case should the punch size be less than .005 in. (0.127 mm).

6.2 The radius of the single pin, mandrel, or punch applying the bend force at the mid-length shall differ not more than ±5 % from the nominal value of the radius.

6.3 The length of all pins, rolls, mandrels, and radius flats must exceed the width of the specimen; they must be strong enough and sufficiently rigid to resist significant deformation.

7. Test Specimens

7.1 Five specimens are required for this test.

7.2 The test specimens may be prepared by cutting, shearing, or stamping.

7.3 The test specimens shall have a width of ½ ± ¼₁₆ in. (12.7 ± 1.57 mm) and of any convenient length greater than ½ in. (12.7 mm) unless specified otherwise by purchaser.

7.4 *Direction of Specimen:*

7.4.1 The bending characteristics of a metal vary with the orientation of the bends to the direction of rolling. A longitudinal or good way bend will take a sharper bend radius than a transverse bend. This characteristic becomes more pronounced as the metal thickness increases.

7.4.2 In a longitudinal (good way bend) specimen, its length shall be parallel to the direction of rolling as indicated in Fig. 1.

7.4.3 In a transverse bend (bad way bend) specimen, its length shall be perpendicular to the direction of rolling as indicated in Fig. 1.

7.4.4 Unless stated otherwise, the length and width of rectangular specimens shall be in the plane of the two major dimensions of the product.

7.5 The specimen thickness shall be measured using a micrometer with a precision of 0.0001 in. (0.00254 mm).

8. Procedure

8.1 *Direction of Test*—All tests shall be performed with the axis of the bend at 90° to the specimen length.

8.2 *90° Bend Test:*

8.2.1 Place the specimen between the supports and apply the bend force until the angle of bend reaches 90°. Release the force and examine the specimen.

8.3 *180° Bend Test:*

8.3.1 Adjust the specimen supports using the dial indicators. Move each support away from the test punch center-line (fully closed position) by a distance equal to the strip thickness plus the punch radius, plus 0.0005 in. (0.013 mm).

8.3.2 Place the specimen between the supports and apply the bend force until an the angle of bend reaches 180°. Release the force and examine the specimen.

8.4 *Pass/Fail Criterion*—To pass either the 90° or 180° bend test, all five specimens shall not exhibit any cracks when examined at a magnification of 30×. (The appearance of orange peel or roughened surface does not constitute a crack.) Metallographic cross-section shall be used as a referee method, examining at 150× magnification.

9. Report

9.1 The results shall be reported as a minimum bend ratio (smallest passing bend test radius/strip thickness). It shall be referenced with the degree of bend (90° or 180°) and test direction (longitudinal or transverse).

10. Retest

10.1 If one out of the five test specimens fails, a retest is permitted. If more than one specimen fails, no retesting is permitted.

10.2 A retest requires an additional five test specimens. All of these specimens must pass the bend test.

11. Precision and Bias

11.1 No information is presented about either precision or bias of Test Method B820 for measuring formability of copper and copper alloy strip since the test result is nonquantitative.

12. Keywords

12.1 bend radius; bend test; copper and copper alloy strip; formability test; fracture; longitudinal bend; mandrel; transverse bend

SUMMARY OF CHANGES

Committee B05 has identified the principal changes to this standard test method that have been incorporated since the B820 – 14 issue as follows (Approved Sept. 1, 2014):

(1) In Section 11.1 the addition of the words “copper and” before the words “copper alloy,” and replace “spring material” with the term “strip.”

Committee B05 has identified the principal changes to this standard test method that have been incorporated since the B820 – 09 issue as follows (Approved April 1, 2014):

(1) Section 1.4 of the Scope and Section 3, Terminology Section, has been revised to reflect Guide B950.

ASTM International takes no position respecting the validity of any patent rights asserted in connection with any item mentioned in this standard. Users of this standard are expressly advised that determination of the validity of any such patent rights, and the risk of infringement of such rights, are entirely their own responsibility.

This standard is subject to revision at any time by the responsible technical committee and must be reviewed every five years and if not revised, either reapproved or withdrawn. Your comments are invited either for revision of this standard or for additional standards and should be addressed to ASTM International Headquarters. Your comments will receive careful consideration at a meeting of the responsible technical committee, which you may attend. If you feel that your comments have not received a fair hearing you should make your views known to the ASTM Committee on Standards, at the address shown below.

This standard is copyrighted by ASTM International, 100 Barr Harbor Drive, PO Box C700, West Conshohocken, PA 19428-2959, United States. Individual reprints (single or multiple copies) of this standard may be obtained by contacting ASTM at the above address or at 610-832-9585 (phone), 610-832-9555 (fax), or service@astm.org (e-mail); or through the ASTM website (www.astm.org). Permission rights to photocopy the standard may also be secured from the Copyright Clearance Center, 222 Rosewood Drive, Danvers, MA 01923, Tel: (978) 646-2600; <http://www.copyright.com/>