



# Standard Specification for Magnesium-Alloy Sand Castings<sup>1</sup>

This standard is issued under the fixed designation B80; the number immediately following the designation indicates the year of original adoption or, in the case of revision, the year of last revision. A number in parentheses indicates the year of last reapproval. A superscript epsilon ( $\epsilon$ ) indicates an editorial change since the last revision or reapproval.

*This standard has been approved for use by agencies of the U.S. Department of Defense.*

## 1. Scope

1.1 This specification covers magnesium-alloy sand castings designated as shown in **Table 1**.

1.2 The values stated in inch-pound units are to be regarded as the standard. The SI values in parentheses are provided for information only.

1.3 *This standard does not purport to address all of the safety concerns, if any, associated with its use. It is the responsibility of the user of this standard to establish appropriate safety and health practices and determine the applicability of regulatory limitations prior to use.*

## 2. Referenced Documents

2.1 The following documents of the issue in effect on date of order acceptance form a part of this specification to the extent referenced herein:

### 2.2 ASTM Standards:<sup>2</sup>

- B93/B93M** Specification for Magnesium Alloys in Ingot Form for Sand Castings, Permanent Mold Castings, and Die Castings
- B296** Practice for Temper Designations of Magnesium Alloys, Cast and Wrought
- B557** Test Methods for Tension Testing Wrought and Cast Aluminum- and Magnesium-Alloy Products
- B660** Practices for Packaging/Packing of Aluminum and Magnesium Products
- B661** Practice for Heat Treatment of Magnesium Alloys
- B951** Practice for Codification of Unalloyed Magnesium and Magnesium-Alloys, Cast and Wrought
- E29** Practice for Using Significant Digits in Test Data to Determine Conformance with Specifications

<sup>1</sup> This specification is under the jurisdiction of ASTM Committee B07 on Light Metals and Alloys and is the direct responsibility of Subcommittee B07.04 on Magnesium Alloy Cast and Wrought Products.

Current edition approved May 1, 2015. Published June 2015. Originally approved in 1930. Last previous edition approved in 2009 as B80–09. DOI: 10.1520/B0080-15.

<sup>2</sup> For referenced ASTM standards, visit the ASTM website, [www.astm.org](http://www.astm.org), or contact ASTM Customer Service at [service@astm.org](mailto:service@astm.org). For *Annual Book of ASTM Standards* volume information, refer to the standard's Document Summary page on the ASTM website.

- E35** Test Methods for Chemical Analysis of Magnesium and Magnesium Alloys (Withdrawn 2008)<sup>3</sup>
- E88** Practice for Sampling Nonferrous Metals and Alloys in Cast Form for Determination of Chemical Composition
- E94** Guide for Radiographic Examination
- E155** Reference Radiographs for Inspection of Aluminum and Magnesium Castings
- E165** Practice for Liquid Penetrant Examination for General Industry
- E527** Practice for Numbering Metals and Alloys in the Unified Numbering System (UNS)
- E716** Practices for Sampling and Sample Preparation of Aluminum and Aluminum Alloys for Determination of Chemical Composition by Spectrochemical Analysis

### 2.3 Federal Standards:<sup>4</sup>

- Fed. Std. No. 123 Marking for Shipment (Civil Agencies)
- Fed. Std. No. 184 Identification Marking of Aluminum, Magnesium and Titanium

### 2.4 Military Standards:<sup>4</sup>

- MIL-STD-129 Marking for Shipment and Storage (Military Agencies)
- MIL-STD-276 Impregnation of Porous Non-ferrous Metal Castings
- MIL-I-13857 Impregnation of Metal Castings
- MIL-M-46062 Magnesium Alloy Castings, High Strength
- MIL-M-6857 Heat Treatment of Magnesium Alloy Castings

### 2.5 ANSI Standard:<sup>5</sup>

- ANSI Z1.4 Sampling Procedures and Tables for Inspection by Attributes

## 3. Terminology

### 3.1 Definitions:

- 3.1.1 *casting lot, n*—unless otherwise agreed, shall consist of not more than 1000 lb of cleaned castings from the same

<sup>3</sup> The last approved version of this historical standard is referenced on [www.astm.org](http://www.astm.org).

<sup>4</sup> Available from Standardization Documents Order Desk, DODSSP, Bldg. 4, Section D, 700 Robbins Ave., Philadelphia, PA 19111-5098, <http://www.dodssp.daps.mil>.

<sup>5</sup> Available from American National Standards Institute (ANSI), 25 W. 43rd St., 4th Floor, New York, NY 10036, <http://www.ansi.org>.

**TABLE 1 Chemical Requirements<sup>A</sup>**

NOTE 1—Analysis shall regularly be made only for the elements specifically mentioned in this table. If, however, the presence of other elements is suspected or indicated in amounts greater than the specified limits, further analysis shall be made to determine that these elements are not present in excess of the specified limits.

NOTE 2—The following applies to all specified limits in this table: For purposes of acceptance and rejection, an observed value or a calculated value obtained from analysis shall be rounded to the nearest unit in the last right-hand place of figures used in expressing the specified limit.

Chemical Composition Limits for Registered Magnesium Alloys																		
Alloy Number <sup>B</sup>	UNS	Magne- sium	Alu- minum	Copper	Gado- linium	Iron	Lithium	Man- gane- se	Neo- dymium	Nickel	Rare Earths	Silicon	Silver	Yttrium	Zinc	Zirconium	Others (Metallic Impurities) Each	Total <sup>C</sup> Impu- rities
AM100A	M10100	remainder	9.3–10.7	0.10	...	...	...	0.10–0.35	...	0.01	...	0.30	...	...	0.30	...	...	0.30
AZ63A	M11630	remainder	5.3–6.7	0.25	...	...	...	0.15–0.35	...	0.01	...	0.30	...	...	2.5–3.5	...	...	0.30
AZ81A	M11810	remainder	7.0–8.1	0.10	...	...	...	0.13–0.35	...	0.01	...	0.30	...	...	0.40–1.0	...	...	0.30
AZ91C	M11914	remainder	8.1–9.3	0.10	...	...	...	0.13–0.35	...	0.01	...	0.30	...	...	0.40–1.0	...	...	0.30
AZ91E	M11919	remainder	8.1–9.3	0.015	...	...	...	0.17–0.35	...	0.0010	...	0.20	...	...	0.40–1.0	...	0.01	0.30
AZ92A	M11920	remainder	8.3–9.7	0.25	...	...	...	0.10–0.35	...	0.01	...	0.30	...	...	1.6–2.4	...	...	0.30
EQ21A	M18330	remainder	...	0.05–0.10	...	...	...	...	...	0.01	1.5–3.0 <sup>E</sup>	...	1.3–1.7	...	...	0.40–1.0	...	0.30
EV31A <sup>F</sup>	M12310	remainder	...	0.01	1.0–1.7	0.010	...	...	2.6–3.1	0.0020	0.4 <sup>G</sup>	...	0.05	...	0.20–0.50	0.40–1.0	0.01	...
EZ33A	M12330	remainder	...	0.10	...	...	...	...	...	0.01	2.5–4.0 <sup>H</sup>	...	...	...	2.0–3.1	0.50–1.0	...	0.30
K1A	M18010	remainder	...	...	...	...	...	...	...	...	...	...	...	...	...	0.40–1.0	...	0.30
QE22A	M18220	remainder	...	0.10	...	...	...	...	...	...	...	...	...	...	...	0.40–1.0	...	0.30
WE43A	M18430	remainder	...	0.03	...	0.01	0.2	0.15	2.0–2.5	0.005	1.9 <sup>I</sup>	0.01	...	3.7–4.3	0.20	0.40–1.0	0.2	...
WE43B	M18432	remainder	...	0.02	...	0.010	0.2	0.03	2.0–2.5	0.005	1.9 <sup>I</sup>	...	J	3.7–4.3	J	0.40–1.0	0.01	...
WE54A	M18410	remainder	...	0.03	...	...	0.2	0.03	1.5–2.0	0.005	2.0 <sup>I</sup>	0.01	...	4.75–5.5	0.20	0.40–1.0	0.20	...
ZC63A	M16331	remainder	...	2.4–3.0	...	...	...	0.25–0.75	...	0.01	...	0.20	...	...	5.5–6.5	...	...	0.30
ZE41A	M16410	remainder	...	0.10	...	...	...	0.15	...	0.01	0.75–1.75 <sup>H</sup>	...	...	...	3.5–5.0	0.40–1.0	...	0.30
ZK51A	M16510	remainder	...	0.10	...	...	...	...	...	0.01	...	...	...	...	3.6–5.5	0.50–1.0	...	0.30
ZK61A	M16610	remainder	...	0.10	...	...	...	...	...	0.01	...	...	...	...	5.5–6.5	0.6–1.0	...	0.30

<sup>A</sup> Limits are in weight % max unless shown as a range or stated otherwise.

<sup>B</sup> ASTM alloy designations were established in accordance with Practice B951. UNS designations were established in accordance with Practice E527.

<sup>C</sup> Includes listed elements for when no specific limit is shown.

<sup>D</sup> If iron exceeds 0.005 %, the Iron to Manganese ratio shall not exceed 0.032.

<sup>E</sup> Rare earth elements are in the form of Didymium, with not less than 70 % Neodymium, and the remainder substantially Praseodymium.

<sup>F</sup> Alloy EV31A is a patented composition, suitable for elevated temperature applications. Interested parties are invited to submit information regarding the identification of alternatives to these compositions to ASTM International. Your comments will receive careful consideration at a meeting of the responsible technical committee, which you may attend. ASTM International takes no position respecting the validity of any patent rights asserted in connection with any item mentioned in this specification. Users of this specification are expressly advised that determination of the validity of any such patent rights, and the risk of infringement of such rights, are entirely their own responsibility.

<sup>G</sup> Other Rare Earths may also be present to a total maximum of 0.4 %. These Rare Earths shall principally be Cerium, Lanthanum, and Praseodymium.

<sup>H</sup> Total Rare Earths (TRE) are principally a mixture of Cerium, Lanthanum, Neodymium and Praseodymium. The Cerium content should not be less than 45% of TRE.

<sup>I</sup> Other Rare Earths shall be principally heavy rare earths, such as, Gadolinium, Dysprosium, Erbium, and Ytterbium. Other Rare Earths are derived from the Yttrium, typically 80 % Yttrium, and 20 % heavy rare earths.

<sup>J</sup> Zinc + Silver shall not exceed 0.20 % in WE43B.

melt or heat, except where this weight limit may be exceeded by a single casting. In such cases, each casting shall be considered a lot.

3.1.2 *heat treat lot, n*—for the purpose of mechanical property testing, a lot shall consist of all castings heat treated in the same furnace charge to the same temper.

3.1.3 *sand casting, n*—metal object produced by pouring molten metal into a sand mold and allowing it to solidify.

#### 4. Ordering Information

4.1 Orders for castings under this specification shall include the following information:

- 4.1.1 Applicable drawing or part number,
- 4.1.2 Quantity of each casting,
- 4.1.3 Specification number and title,
- 4.1.4 Alloy (Section 9 and Table 1),
- 4.1.5 Temper (Section 11, Table 2 and X1.2),
- 4.1.6 Whether foundry control is required (Section 8),
- 4.1.7 Whether test specimens cut from castings are required in addition to, or instead of, separately cast test specimens (Section 12 and Table X1.2),
- 4.1.8 Whether liquid penetrant inspection is required (15.2),
- 4.1.9 Whether radiographic inspection is required (15.3),
- 4.1.10 Whether pressure testing is required (15.4),
- 4.1.11 Whether source inspection is required (Section 17),

4.1.12 Whether repairs are permissible (Section 19),

4.1.13 Whether chemical analysis and mechanical property reports or certifications, or both, are required (Section 20), and

4.1.14 Whether special packaging is required for shipment (Section 22).

#### 5. Responsibility for Quality Assurance

5.1 *Responsibility for Inspection*—Unless otherwise specified in the contract or purchase order, the supplier is responsible for the performance of all inspection requirements as specified herein. Except as otherwise specified in the contract or order, the supplier may use his own or any other facilities suitable for the performance of the inspection requirements specified herein, unless disapproved by the purchaser. The purchaser reserves the right to perform any of the inspections set forth in the specification where such inspections are deemed necessary to ensure supplies and services conform to prescribed requirements.

#### 6. Material Requirements

6.1 Unless otherwise specified, only magnesium alloy ingots or producer's foundry scrap conforming to Specification B93/B93M shall be used for pouring castings. Additions of small amounts of grain refining elements and material for melt process losses are permitted.

**TABLE 2 Tensile Requirements**

NOTE 1—For purposes of determining conformance with this specification, each value for tensile strength and yield strength shall be rounded to the nearest 0.1 ksi and each value for elongation shall be rounded to the nearest 0.5 %, both in accordance with the rounding method of Practice E29.

Alloy Number		Temper <sup>A</sup>	Tensile Strength, min, ksi (MPa)	Yield Strength <sup>B</sup> (0.2 % offset), min, ksi (MPa)	Elongation in 2 in., (50.8 mm) min, %
ASTM	UNS				
AM100A	M10100	T6	35.0(241)	17.0(117)	<sup>C</sup>
AZ63A	M11630	F	26.0(179)	11.0(76)	4
		T4	34.0(234)	11.0(76)	7
		T5	26.0(179)	12.0(83)	2
		T6	34.0(234)	16.0(110)	3
		T6	34.0(234)	11.0(76)	7
AZ81A	M11810	T4	34.0(234)	11.0(76)	7
AZ91C	M11914	F	23.0(158)	11.0(76)	<sup>C</sup>
		T4	34.0(234)	11.0(76)	7
		T5	23.0(158)	12.0(83)	2
		T6	34.0(234)	16.0(110)	3
		T6	34.0(234)	16.0(110)	3
AZ91E	M11919	T6	34.0(234)	16.0(110)	3
AZ92A	M11920	F	23.0(158)	11.0(76)	<sup>C</sup>
		T4	34.0(234)	11.0(76)	6
		T5	23.0(158)	12.0(83)	<sup>C</sup>
		T6	34.0(234)	18.0(124)	1
		T6	34.0(234)	25.0(172)	2
EQ21A	M18330	T6	34.0(234)	25.0(172)	2
EV31A	M12310	T6	36.0(248)	21.0(145)	2
EZ33A	M12330	T5	20.0(138)	14.0(96)	2
K1A	M18010	F	24.0(165)	6.0(41)	14
QE22A	M18220	T6	35.0(241)	25.0(172)	2
WE43A	M18430	T6	32.0(221)	25.0(172)	2
WE43B	M18432	T6	32.0(221)	25.0(172)	2
WE54A	M18410	T6	37.0(255)	26.0(179)	2
ZC63A	M16331	T6	28.0(193)	18.0(124)	2
ZE41A	M16410	T5	29.0(200)	19.5(133)	2.5
ZK51A	M16510	T5	34.0(234)	20.0(138)	5
ZK61A	M16610	T6	40.0(276)	26.0(179)	5

<sup>A</sup> These temper designations were established in accordance with Practice B296.

<sup>B</sup> See X1.4.1.

<sup>C</sup> Not required.

6.2 Pure materials and master alloys may be used provided chemical analysis verifying conformance to **Table 1** is done prior to pouring any castings.

## 7. Manufacture

7.1 The responsibility of furnishing castings that can be laid out and machined to the finished dimensions within the permissible variations specified, as shown on the blueprints or drawings, shall rest with the supplier, except when pattern equipment is furnished by the purchaser. Sufficient stock shall be allowed for shrinkage, and where requested, for finishing; but castings of excessive weight shall not be furnished.

7.2 The castings may be subjected to such heat treatment as deemed necessary to produce material that will conform to the requirements specified. Heat treatment shall be performed on the whole of a casting, never on a part only, and shall be applied in a manner that will produce the utmost uniformity.

## 8. Foundry Control

8.1 When specified, castings shall be produced under foundry control approved by the purchaser. Foundry control shall consist of examination of the castings by radiographic or other approved methods for determining internal discontinuities until the gating, pouring, and other foundry practices have been established to produce castings meeting the quality standards set by purchaser or agreed to between the purchaser and the producer. When foundry practices have been so established, the production method shall not be significantly changed without demonstrating to the satisfaction of the purchaser that the change does not adversely affect the quality of the castings. Minor changes in pouring temperature of  $\pm 50^{\circ}\text{F}$  from the established nominal temperature are permissible.

## 9. Chemical Composition Requirements

9.1 *Limits*—The castings shall conform to the chemical composition limits prescribed in **Table 1**. Conformance shall be determined by analyzing samples taken when the castings are poured, or by analyzing samples taken from the finished product. If the chemical composition has been determined during the course of manufacture, sampling and analysis of the finished product shall not be necessary.

## 10. Sampling for Chemical Composition

10.1 For determination of chemical composition, one sample of each casting lot shall be taken in accordance with Practice **E88** for chemical analysis or Practice **E716** for spectrochemical analysis.

10.1.1 Samples for other methods of chemical analysis shall be suitable for the form of material being analyzed and the type of analytical method used. In case of dispute, analyses should be made by methods given in Methods **E35**.

## 11. Heat Treatment

11.1 Unless otherwise specified, heat treatment for the applicable tempers designated in **Tables 2 and X1.2** shall be in accordance with Military Specification MIL-M-6857 or Prac-

tice **B661**. Heat treatment shall be performed on the whole casting and never on a portion.

11.2 Each heat treat furnace charge shall contain at least one set of test bars of the same composition range as the castings. The satisfactory heat treatment of the furnace charge shall be determined by the results from these test bars, which must conform to the requirements of **Table 2** or **Table X1.2** where required.

## 12. Tensile Requirements

12.1 *Limits*—The tension test specimens representing the castings shall conform to the requirements of **Table 2**.

12.2 *Number of Tests*—At least one tension test specimen shall be tested from each casting lot, or fraction thereof, to represent the castings poured from the same melt. If the castings are to be heat treated, the specimens shall be heat treated with production castings of the same alloy and in the same temper as the specimens. The specimens shall then be tested to judge the ability of their corresponding melts to respond to the type of heat treatment to which the specimens were subjected.

12.2.1 *Test Specimens*—The tension test specimens shall be separately cast in the system sand mix in use and shall be cast to size in accordance with the dimensions shown in **Fig. 1** or **Fig. 2**.

12.3 When specified, the tensile strength and yield strength values of specimens cut from castings shall conform to **Table X1.2**. Elongation values shall not be less than 25 % of the values specified in **Table 2**.

12.3.1 When tensile properties of castings are to be determined, tension test specimens shall be cut from the locations designated on the drawing. If no locations are designated, specimens shall be taken from each test casting to include at least one from the thinnest and one from thickest section of the casting. At least three specimens are required.

12.3.2 The machined tension test specimen shall be the standard 0.500-in. diameter specimen or the largest smaller size specimen proportional to the standard specimen shown in **Fig. 8** of Test Methods **B557**.

12.3.3 Where a round specimen is not feasible a standard 1/2 in. wide rectangular specimen shown in **Fig. 6** of Test Methods **B557** may be used, but in no case shall its area be less than that of the sub size 1/4 in. wide specimen.

12.4 If any tension test specimen is improperly machined or shows flaws upon testing, it may be discarded and another specimen for the same heat or melt used instead. If no additional specimen is available, the supplier and the purchaser shall agree on an alternative procedure.

12.5 *Test Methods*—The tension tests shall be made in accordance with Test Methods **B557**.

12.6 *Mechanical properties at 400 to 500°F*—Alloys EQ21A, EV31A, EZ33A, QE22A, WE54A, WE43A and WE43B shall be capable of meeting the requirements shown in **Table X1.2** when tested in the following manner. Tensile test specimens shall be heated to 400 to 500°F  $\pm 5^{\circ}\text{F}$ , as applicable, held for 10 min before testing and loaded at this temperature at

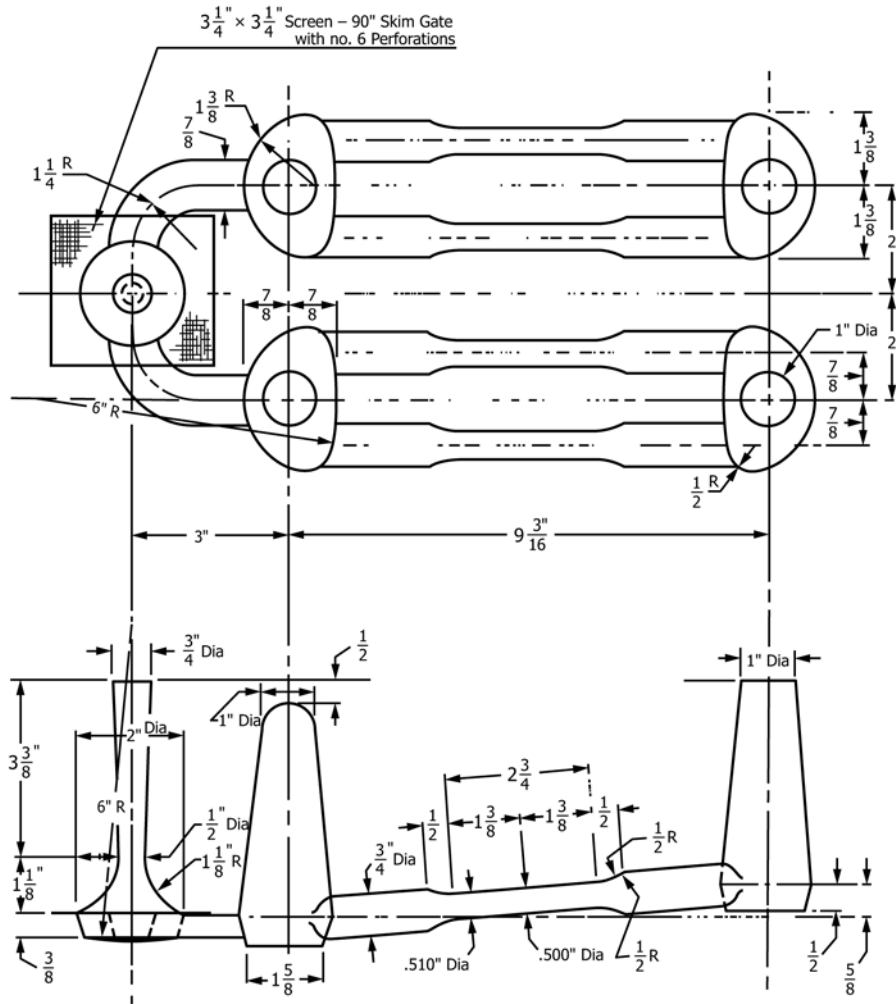

		Metric Equivalents					
in.	mm	in.	mm	in.	mm	in.	mm
0.500	12.70	7/8	22.2	1 3/8	34.9	3	76.2
0.510	12.95	1	25.4	1 5/8	41.37	3 1/4	82.5
3/8	9.5	1 1/8	28.6	2	50.8	6	152.4
1/2	12.7	1 1/4	31.8	2 3/4	69.8	9 3/16	233.4
5/8	15.9						

FIG. 1 AFS Test Bar for Sand-Cast Magnesium Alloys

a rate of 0.005 in./in./min up to the yield strength, and at a rate of 0.10 in./in./min above the yield strength.

### 13. Special Test Methods

13.1 When the castings have critical functional requirements, special tests to simulate the stress conditions incurred in service may be requested. The requirements and methods of these tests shall be as agreed upon between the producer and the purchaser.

### 14. Finish

14.1 The finished castings shall be uniform in quality, free of injurious blowholes, porosity, shrinkage, cracks, and other

discontinuities except as designated and agreed upon as acceptable by the purchaser.

14.2 Prior to shipment, castings shall be coated with a light corrosion-inhibiting oil, unless chrome pickling is required by the purchaser (see X1.5).

### 15. Foundry Inspection

15.1 Requirements of surface finish parting lines, and removal of gates and risers may be checked visually. It is advisable to have mutually agreed upon observational standards to represent acceptable material.

15.2 *Liquid Penetrant Inspection:*



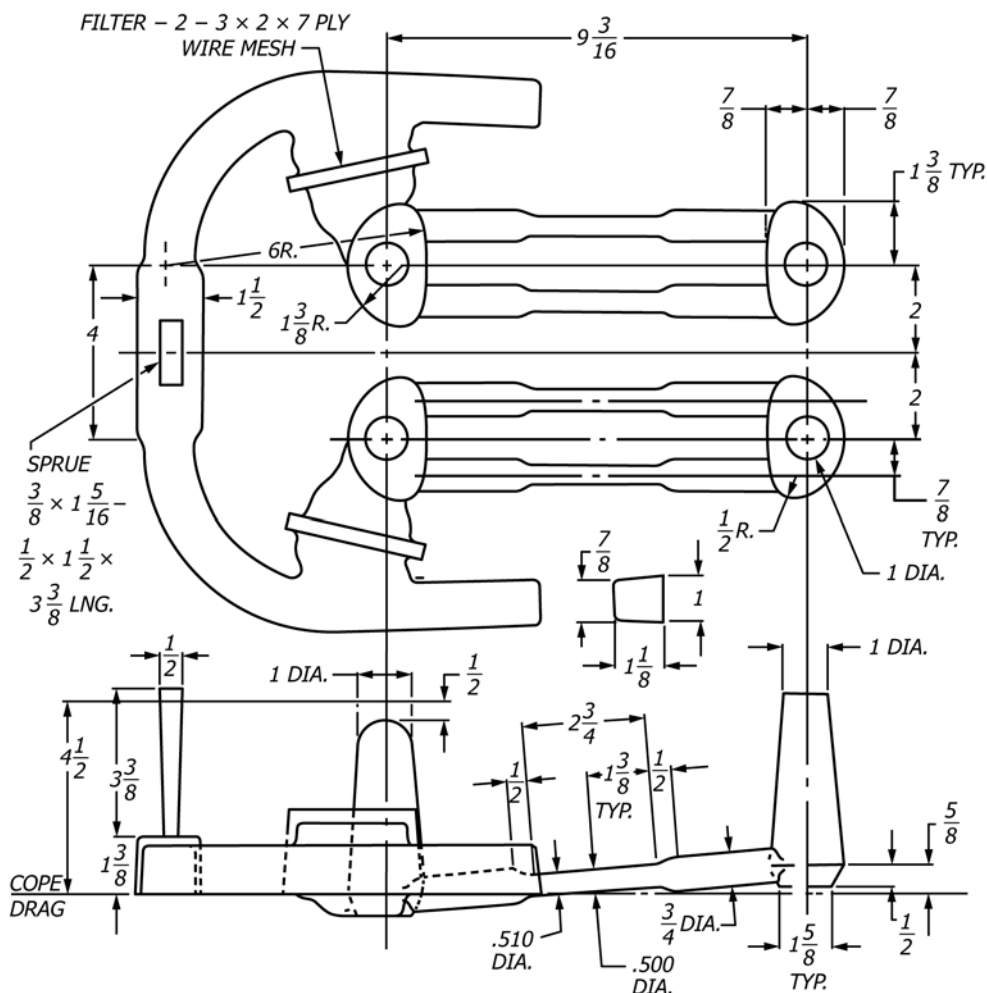

NOTE 1—This test bar mold is particularly suitable for those magnesium alloys containing Zr.

FIG. 2 Proposed Gating System for ASTM Magnesium Test Bars

15.2.1 When specified liquid penetrant inspection shall be in accordance with Practice E165, and the required sensitivity shall be specified.

15.2.2 Acceptance standards for discontinuities shall be agreed upon, including size and frequency per unit area and location.

15.3 Radiographic Inspection:

15.3.1 When specified, radiographic inspection shall be in accordance with Guide E94 and Reference Radiographs E155 to determine soundness. Areas of the casting subject to

soundness requirements shall be specified by the purchaser. It is advisable to document an agreed upon radiographic technique including source parameters, film size, and orientation of the radiographs.

15.3.2 Radiographic acceptance shall be in accordance with requirements selected from Table 3. Any modifications of this table and the frequency per unit area and location should also be agreed upon between the producer and purchaser.

15.4 When specified, the castings shall be subject to hydrostatic or aerostatic pressure as required. Acceptance pressure

TABLE 3 Discontinuity-Level Requirements for Magnesium Sand Castings (Reference Radiographs E155)

Discontinuity	Grade A		Grade B			Grade C		Grade D	
	1/4	3/4	1/4	3/4	1/4	3/4	1/4	3/4	
Gas holes	none	1	1	1	2	2	5	5	
Microshrinkage (feathery)	none	1	1	1	2	2	4	3	
Microshrinkage (sponge)	none	1	1	1	2	2	4	3	
Foreign material (less dense)	none	1	1	1	2	2	4	4	
Foreign material (more dense)	none	1	1	1	2	2	4	3	
Cracks	none		none		none		none		
Cold shuts	none		none		none		none		
Surface irregularity			not to exceed drawing tolerance						
Core shift			not to exceed drawing tolerance						

and allowable leak rates shall be specified by the purchaser. (**Warning**—Take appropriate safety precautions to protect inspectors prior to any pressure application.)

## 16. Sampling for Foundry Inspection

16.1 For the purpose of visual and dimensional examination, casting lots may be combined up to a maximum of 5000 lbs. From this accumulated lot, a sample shall be selected at random in accordance with the tables of ANSI Z1.4 at inspection level II, with lot acceptance and rejection based on acceptable quality level (AQL) equal to 1.5 % defective. When the accumulation of lots is not practical, the sample shall be selected from each casting lot. Samples selected for dimensional examination may be the same as those selected for visual examination, but the determination of acceptance or rejection shall not be based on the cumulative sample for both characteristics.

16.2 For the purpose of liquid penetrant or radiographic inspection, a random sample of castings shall be selected from each casting lot. The number of castings selected shall be in accordance with ANSI Z1.4 at inspection quality level II with lot acceptance and rejection based on AQL of 0.65 % defective.

16.3 Sampling for hydrostatic and aerostatic pressure tests shall be as specified by the purchaser.

16.4 Modifications of the above sampling plans must be agreed upon between the producer and the purchaser.

## 17. Source Inspection

17.1 If the purchaser desires that inspection be made at the supplier's works where the material is made, it shall be so stated in the contract or purchase order.

17.1.1 If the purchaser elects to have the inspection made at the supplier's works, the supplier shall afford the inspector representing the purchaser all reasonable facilities to satisfy him that the material is being furnished in accordance with this specification. All tests and inspection shall be so conducted as not to interfere unnecessarily with the operation of the works.

## 18. Rejection, Retest and Reheating

18.1 Material failing to conform to the requirements of this specification, or in which defects are found during subsequent manufacturing operations, may be rejected. If rejected, the supplier shall be responsible only for replacement of the material to the purchaser. As much as possible of the rejected original material shall be returned to the supplier.

18.1.1 Any sample unit containing one or more characteristics which fail to meet any of the requirements of this standard shall be rejected. If the number of defective units in any sample exceeds the acceptance number specified for that sample size, the entire lot represented by the sample shall be rejected.

18.1.2 A rejected lot may be screened by 100 % inspection for the rejectable item and resubmitted for acceptance inspections. Any deviation from this procedure must be approved by the purchaser.

18.2 *Retests*—If the results of the tension tests of alloys in heat-treated tempers do not conform to the requirements

prescribed in [Table 2](#) or [Table X1.2](#), the castings may be reheat treated but not more than twice. The results of acceptable tests shall conform to the requirements as to tensile properties specified in [Table 2](#) or [Table X1.2](#).

18.3 In the case of dissatisfaction regarding rejections, the producer may make a claim for rehearing as the basis for arbitration within a reasonable time after receipt by the producer of the rejection notification.

## 19. Repair of Castings

19.1 Castings shall not be repaired by welding, impregnation, peening, excess blendings resulting in out of drawing tolerance dimension, or other methods without permission of the purchaser. Soldering shall not be performed under any conditions. Limitations on the extent and frequency of repairs, and methods of inspection of repaired areas shall be as agreed upon by the producer and purchaser. Repaired castings shall be re-examined in accordance with the applicable areas of the drawings, specifications and directives and shall fully comply with all the requirements of this standard.

19.2 *Welding*—When welding is permitted, it shall be done by methods suitable for the particular alloy. Welding methods shall be in accordance with such specifications as are referenced on the applicable drawings, or as are required by the contract or order. Periodic checks of welded castings shall be made to ensure a satisfactory procedure for welding is being adhered to by the producer.

19.2.1 All welding shall be done by qualified welders approved by the purchaser.

19.2.2 When castings are to be supplied in the heat treated condition, they shall be heat treated or re-heat treated, with proper precautions against germination, to the required temper after welding. Small arc welds may be performed without subsequent heat treatment upon approval of the purchaser.

19.2.3 When specified, castings that have been repaired by welding shall have the welded areas examined radiographically after all reworking and heat treatments have been completed.

19.2.4 All welds shall be free of cracks, excess gas, oxides, porosity, and lack of fusion.

19.2.5 Welded castings shall be marked with a symbol of three concentric circles with a letter or number designating the welder adjacent to the symbol. The outer circle of the symbol shall not be larger than ¼ in. outside diameter. All welded areas shall be encircled with a ring of white paint prior to submission for final inspection.

19.3 *Impregnation*—When impregnation is permitted it shall be only to correct general seepage leaks and shall not be used to correct poor foundry technique or significant porosity. It shall be accomplished in accordance with such specifications as may be shown on the drawing or that may be required by the contract or order, provided that, if no specifications are stipulated, the method used shall be approved by the procuring agency. Unless otherwise authorized, castings which have been impregnated shall be marked *IMP*. Impregnation of castings shall be in accordance with Military Standard MIL-STD-276. For Aeronautical and Army Quartermaster Corps use, impregnants used shall be in accordance with Military Specification MIL-I-13857.

19.4 *Peening*—Where peening is permitted it shall be only to correct localized minor seepage leaks and small surface imperfections, or to disclose sub-surface voids for the purpose of inspection. Peening shall not be permitted to repair cracks, cold shuts, shrinks, mis-runs, defects due to careless handling, or other similar major defects. Peening may be accomplished either hot or cold and shall be performed by methods which are acceptable to the inspector. Peened castings shall be marked with a maltese cross approximately ¼ in. high.

19.5 *Blending*—Blending with suitable grinders or other tools shall be permitted only for the removal of surface imperfections and shall not result in dimensions below minimum drawing tolerances.

## 20. Certification

20.1 The supplier shall, on request, furnish to the purchaser a certificate stating that the material has been sampled and inspected in accordance with this specification, and has met the requirements.

## 21. Identification and Repair Marking

21.1 *Identification*—Unless otherwise specified, each casting shall be marked with the applicable drawing or part number. The marking shall consist of raised Arabic numerals, and when applicable, capital letters, cast integral. The location of the identification marking shall be as specified on the drawing, the drawing/part number shall be placed in a location mutually agreeable to the purchaser and producer.

21.1.1 *Lot Identification*—When practical, each casting shall also be marked with the lot number.

21.2 *Repair Markings*—All identification markings indicating repairs as specified in 19.2.5, 19.3 and 19.4 shall be made with a waterproof marking fluid.

## 22. Packaging and Marking for Shipment

22.1 *Packaging*—Unless otherwise specified, the castings shall be packaged to provide adequate protection during normal handling and transportation. Each package shall contain only one type of item unless otherwise agreed upon. The type of packaging and gross weight of containers shall, unless otherwise agreed upon, be at the supplier's discretion, provided they are such as to ensure acceptance by common or other carriers for safe transportation at the lowest rate to the delivery point.

22.2 *Marking*—Each shipping container shall be legibly marked with the purchase order number, gross and net weights, and the supplier's name. Marking for shipment shall be in accordance with Fed. Std. No. 123 for civil agencies and MIL-STD-129 for military agencies. When specified in the contract or purchase order materials shall be marked in accordance with Fed. Std. 184.

22.3 *Preservation*—Material intended for prolonged storage in unheated locations shall be adequately packed and protected to avoid deterioration and damage. When specified in the contract or purchase order, material shall be preserved, packaged, and packed in accordance with the requirements of Practice B660. The applicable levels shall be as specified in the contract or order.

22.4 When required, an examination of preparation for delivery shall be made to determine compliance with the packing requirements. The sample unit shall be one shipping container fully prepared for delivery, randomly selected. Using MIL-STD-105, the inspection level shall be an AQL of 4.0 expressed in terms of percent defective.

## 23. Keywords

23.1 magnesium alloy; sand castings

## APPENDIX

### (Nonmandatory Information)

## XI. EXPLANATORY NOTES

### XI.1 General Information

XI.1.1 Property limits in Table 2 are based on an analysis of data from separately cast tension test bars and are established at a level at which at least 99 % of the population of the values meets the established value.

XI.1.2 Alloy AM100A has a specific gravity of about 1.81. It is used both in the solution heat-treated temper and in the solution heat-treated and aged temper. Aging increases the yield strength and hardness and decreases the toughness and elongation.

XI.1.3 Alloy AZ63A has a specific gravity of about 1.84. It is used in the as-cast, the solution heat-treated, and the solution heat-treated and aged tempers. Its properties are somewhat

better and its resistance to salt-water (NaCl) corrosion is decidedly better than in the case of alloy AM100A.

XI.1.4 Alloy AZ81A has a specific gravity of about 1.80. It is used primarily in the solution heat-treated temper. This alloy will produce castings having maximum soundness with moderate mechanical properties.

XI.1.5 Alloy AZ91C has a specific gravity of about 1.81. It should be used for those applications requiring the maximum of strength and hardness as well as ductility. Its mechanical properties in the heat-treated and in the heat-treated and aged temper are similar to those of AZ63A, but its foundry characteristics are similar to AZ92A. It should be used in preference to AZ62A. It should be used in preference to AZ63A if the



higher resistance to salt-water (NaCl) corrosion of the latter composition is not required.

X1.1.6 Alloy AZ91E is a high purity version of AZ91C. As a result it has very high resistance to salt-water (NaCl) corrosion.

X1.1.7 Alloy EQ21A has lower silver content than QE22A alloy but has similar mechanical properties.

X1.1.8 Alloy AZ92A has a specific gravity of about 1.82. It is used where good soundness and mechanical properties are required. The alloy is heat treatable and is then characterized by high strength and hardness. Its resistance to salt-water (NaCl) corrosion is approximately equivalent to that of Alloy AZ63A. Alloy AZ92A in the heat-treated temper ages more rapidly than Alloy AZ63A in the heat-treated temper. Under service conditions where the castings attain a temperature of 200°F (93°C) or higher, the castings of Alloy AZ92A, heat treated, will gradually change to the heat-treated and aged temper.

X1.1.9 Alloy EZ33A has a specific gravity of about 1.84. It is used in the artificially-aged temper. It is recommended for use at elevated temperatures, especially in the range of 300 to 500°F (149 to 260°C). This alloy will produce sound castings for pressure tightness.

X1.1.10 Alloy K1A is a low-strength alloy generally used for its exceptionally good damping characteristics.

X1.1.11 Alloy QE22A is primarily used where a high yield strength is needed at temperatures up to 400°F (200°C).

X1.1.12 Alloy ZE41A has a specific gravity of about 1.84. It is a versatile, medium strength, fully weldable and easily castable alloy possessing good fatigue and creep properties. This alloy will produce sound castings for pressure tightness. At testing temperatures up to 320°F (160°C), the properties of separately cast test bars bear a very close relationship to those obtained from sound production castings, even where thick (massive) sections are involved.

X1.1.13 Alloy ZK51A has a specific gravity of about 1.83. It is used in the artificially aged temper. This alloy produces castings combining a high yield strength with good elongation.

X1.1.14 Alloy ZK61A has a specific gravity of about 1.83. It is used in the solution heat-treated and artificially aged temper. This alloy produces castings of highest strength-to-weight ratio and good elongation.

X1.1.15 Alloys WE43A and WE43B have a specific gravity of 1.84. They can be used in castings requiring high yield strength up to 500°F (260°C) and have very high resistance to salt water (NaCl) corrosion.

X1.1.16 Alloy WE54A has a specific gravity of 1.85. It can be used in castings requiring high yield strength up to 500°F

(260°C) and has very high resistance to salt water (NaCl) corrosion. Ductility of alloy WE54A can fall as much as 50 % when exposed to 250 to 400°F (120 to 200°C) for long periods of time.

X1.1.17 Alloy ZC63A has a specific gravity of 1.87. It is suitable for commercial applications where pressure tightness and elevated temperature properties are required.

X1.1.18 Alloy EV31A has a specific gravity of 1.82. It can be used in castings requiring high yield strength up to 400°F (200°C) and has very high resistance to salt water (NaCl) corrosion.

## X1.2 Properties and Characteristics

X1.2.1 The data on properties and characteristics given in [Table X1.1](#) are approximate and are supplied for general information only.

## X1.3 Minimum Properties of Bars Cut from Castings

X1.3.1 The minimum properties of bars cut from castings shown in [Table X1.2](#) are given for information only and do not form a part of this specification. The minimums in [Table X1.2](#) are available for most castings although better properties may be obtained in some castings or selected sections of other castings. All properties of bars cut from castings require special agreement between the purchaser and the manufacturer.

X1.3.2 Military Specification MIL M-46062 High Strength Magnesium Alloy Castings, covers castings of a premium quality for which all properties required are from specimens cut from the castings.

## X1.4 Yield Strength and Brinell Hardness

X1.4.1 The yield strength of magnesium-base alloys is defined as the stress at which the stress-strain curve deviates 0.2 % from the modulus line. It may be determined by the “offset method” or the “extension-under-load method” (the latter is often referred to as the “approximate method without the stress-strain diagram”) as described in [Methods B557](#). In case of dispute, the “offset method” shall be used. The data in [Table X1.3](#) give minimum yield strength values for the various alloys, together with the corresponding unit deformations for use with the “extension-under-load method” based on a modulus of elasticity,  $E = 6\,500\,000$  psi (44 800 MPa).

X1.4.2 The typical Brinell hardness numbers shown in [Table X1.3](#) were obtained using a 10 mm ball and 500 kgf load. They are shown for information only.

## X1.5 Chrome Pickling

X1.5.1 The chrome pickle is not recommended for castings containing metal inserts.

**TABLE X1.1 Properties and Characteristics**

Alloy Number		Melting Range Approximate, °F (°C)			Pattern Shrinkage	Foundry Characteristics <sup>B</sup>					Other Characteristics <sup>B</sup>			
ASTM	UNS	Non- Equilib- rium Solidus <sup>C</sup>	Solidus	Liquidus	Allow- ance, in./ft <sup>A</sup> (mm/m)	Pres- sure Tight- ness	Fluidity <sup>D</sup>	Micro- porosity Tend- ency <sup>E</sup>	Normally Heat Treated	Machin- ing <sup>F</sup>	Electro- plating <sup>G</sup>	Sur- face Treat- ment <sup>H</sup>	Suita- bility to Braze <sup>I</sup>	Suita- bility to Welding <sup>J</sup>
AM100A	M10100	810	867(464)	1100(593)	5/32 (13.0)	2	1	2	yes	1	2	2	no	1
AZ63A	M11630	685	850(454)	1130(610)	5/32 (13.0)	3	1	3	yes	1	1	1	no	3
AZ81A	M11810	790	882(472)	1115(602)	5/32 (13.0)	2	1	2	yes	1	2	2	no	1
AZ91C	M11914	785	875(468)	1105(596)	5/32 (13.0)	2	1	2	yes	1	2	2	no	1
AZ91E	M11919	785	875(468)	1105(596)	5/32 (13.0)	2	1	2	yes	1	2	2	no	1
AZ92A	M11920	770	830(443)	1100(593)	5/32 (13.0)	2	1	2	yes	1	2	2	no	2
EQ21A	M18330	...	995(535)	1184(640)	5/32 (13.0)	2	2	2	yes	1	2	1	<sup>K</sup>	1
EV31A	M12310	...	1013(545)	1184(640)	3/16 (15.5)	2	2	2	yes	1	2	2	<sup>K</sup>	1
EZ33A	M12390	...	1010(543)	1189(643)	3/16 (15.5)	1	2	1	yes	1	1	1	no	1
K1A	M13010	...	...	1205(652)	3/16 (15.5)	2	2	2	no	1	3	2	<sup>K</sup>	1
QE22A	M18220	...	1020(549)	1190(643)	5/32 (13.0)	2	2	2	yes	1	2	1	<sup>K</sup>	1
WE43A	M18430	...	1015(545)	1185(640)	3/16 (15.5)	2	2	2	yes	1	<sup>K</sup>	2	<sup>K</sup>	2
WE43B	M18432	...	1015(545)	1185(640)	3/16 (15.5)	2	2	2	yes	1	<sup>K</sup>	2	<sup>K</sup>	2
WE54A	M18410	...	1015(545)	1185(640)	3/16 (15.5)	2	2	2	yes	1	<sup>K</sup>	2	<sup>K</sup>	2
ZC63A	M16331	...	870(465)	1020(550)	3/16 (15.5)	1	2	2	yes	1	<sup>K</sup>	1	<sup>K</sup>	2
ZE41A	M16410	...	950(510)	1184(640)	5/32 (13.0)	2	2	2	yes	1	1	1	no	2
ZK51A	M16510	...	1020(549)	1185(641)	5/32 (13.0)	3	2	3	yes	1	2	1	no	3
ZK61A	M16610	...	985(529)	1175(635)	5/32 (13.0)	3	2	3	yes	1	2	1	no	3

<sup>A</sup> Allowance for average castings. Shrinkage requirements will vary with intricacy of design and dimensions.

<sup>B</sup> Rating of 1 indicates best of group; 3 indicates poorest of group.

<sup>C</sup> As measured on metal solidified under normal casting conditions.

<sup>D</sup> Ability of liquid alloy to flow readily in mold and fill thin sections.

<sup>E</sup> Based on radiographic evidence.

<sup>F</sup> Composite rating based on ease of cutting, chip characteristics, quality of finish, and tool life. Ratings, in the case of heat-treatable alloys based on T6 type temper. Other tempers, particularly the annealed temper, may have lower rating.

<sup>G</sup> Ability of casting to take and hold an electroplate applied by present standard methods.

<sup>H</sup> Ability of castings to be cleaned in standard pickle solutions and to be conditioned for best paint adhesion.

<sup>I</sup> Refers to suitability of alloy to withstand brazing temperature without excessive distortion or melting.

<sup>J</sup> Based on ability of material to be fusion welded with filler rod of same alloy, or of an alloy whose composition is recommended.

<sup>K</sup> Inexperience with these alloys under wide production conditions makes it undesirable to supply ratings at this time.

**TABLE X1.2 Tension Test Minimums for Specimens Cut from Castings**

NOTE 1—The values in the table, both average and minimum, are representative of the weakest areas in any type casting for the composition listed, that is, adjacent to gates and risers. Higher design properties for designated areas in castings are normally obtained and shall be as specified in the order.

Alloy Number		Temper	Temperature of Testing	Tensile Strength, ksi (MPa)		Yield Strength (0.2 % offset), ksi (MPa)	
ASTM	UNS			avg <sup>A</sup>	min <sup>B</sup>	avg <sup>A</sup>	min <sup>B</sup>
AZ63A	M11630	T4	room	25.5(173)	17.0(117)	10.0(69)	9.0(62)
		T6	room	25.5(173)	17.0(117)	14.5(99)	12.0(83)
AZ81A	M11810	T4	room	25.5(173)	17.0(117)	10.0(69)	9.0(62)
AZ91C	M11914	T4	room	25.5(173)	17.0(117)	10.0(69)	9.0(62)
		T6	room	25.5(173)	17.0(117)	14.5(99)	12.0(83)
AZ91E	M11919	T6	room	25.5(173)	17.0(117)	14.5(99)	12.0(83)
AZ92A	M11920	T4	room	25.5(173)	17.0(117)	10.0(69)	9.0(62)
		T6	room	25.5(173)	17.0(117)	16.0(110)	13.5(92)
EQ21A	M18330	T6	room	32.0(221)	28(193)	23.0(158)	20.0(138)
		T6	400°F	...	23.0(158)	...	18.0(124)
EV31A	M12310	T6	room	41.1(283)	36.0(248)	24.5(169)	21.0(145)
		T6	400°F	35.5(242)	...	21.8(150)	...
EZ33A	M12330	T5	room	15.0(103)	13.0(90)	12.5(86)	11.0(76)
		T5	500°F	...	10.0(69)	...	6.0(41)
QE22A	M18220	T6	room	32.0(221)	28.0(113)	23.0(158)	20.0(138)
		T6	400°F	...	24.0(165)	...	18.0(124)
WE43A	M18430	T6	room	36.5(252)	31.5(215)	25.5(176)	22.0(152)
		T6	482°F	30.5(210)	25.5(176)	22.5(155)	18.5(128)
WE43B	M18432	T6	room	36.5(252)	31.5(215)	25.5(176)	22.0(152)
		T6	482°F	30.5(210)	25.5(176)	22.5(155)	18.5(128)
WE54A	M18410	T6	room	35.0(240)	30.5(210)	24.0(165)	23.0(160)
		T6	482°F	...	27.0(185)	...	22.0(150)
ZC63A	M16331	T6	room	...	27.0(185)	...	18.0(124)
ZE41A	M16410	T5	room	28.0(193)	26.0(179)	19.5(135)	17.5(120)
ZK51A	M16510	T5	room	29.0(209)	24.0(165)	17.0(117)	14.0(96)
ZK61A	M16610	T6	room	34.0(234)	30.0(207)	...	21.0(145)

<sup>A</sup> The average value of all specimens tested from each casting shall conform to the minimum average. Not less than three specimens shall be tested from each casting: one from the thinnest section, one from the thickest section, and one from an intermediate section.

<sup>B</sup> Any specimen cut from a casting shall conform to the minimum value specified.

**TABLE X1.3 Data for Use with “Extension-Under Load Method” and Typical Brinell Hardness**

Alloy Number		Temper	Yield Strength (0.2 % offset), min, ksi (MPa)	Unit Deformation, in./in. (mm/mm) of gage length	Typical Brinell Hardness Number, HB
ASTM	UNS				
AM100A	M10100	T6	17.0 (117)	0.0046	69
AZ63A	M11630	F	11.0 (76)	0.0037	50
		T4	11.0 (76)	0.0037	55
		T5	12.0 (83)	0.0038	55
		T6	16.0 (110)	0.0045	73
		T4	11.0 (76)	0.0037	55
AZ81A	M11810	T4	11.0 (76)	0.0037	60
AZ91C	M11914	F	11.0 (76)	0.0037	55
		T4	11.0 (76)	0.0037	62
		T5	12.0 (83)	0.0038	55
AZ91E	M11919	T6	16.0 (110)	0.0045	70
		T6	16.0 (110)	0.0045	70
AZ92A	M11920	F	11.0 (76)	0.0037	65
		T4	11.0 (76)	0.0037	63
		T5	12.0 (83)	0.0038	69
		T6	18.0 (129)	0.0048	81
EQ21A	M18330	T6	25.0 (172)	0.0058	78
EV31A	M12310	T6	21.0 (145)	0.0052	78
EZ33A	M12330	T5	14.0 (96)	0.0042	50
K1A	M18010	F	6.0 (41)	0.0029	...
QE22A	M18220	T6	25.0 (172)	0.0058	78
WE43A	M18430	T6	25.0 (172)	0.0058	85
WE43B	M18432	T6	25.0 (172)	0.0058	85
WE54A	M18410	T6	26.0 (179)	0.0060	85
ZC63A	M16331	T6	18.0 (124)	0.0048	60
ZE41A	M16410	T5	19.5 (135)	0.0050	62
ZK51A	M16510	T5	20.0 (138)	0.0051	65
ZK61A	M16610	T6	26.0 (174)	0.0060	70

*ASTM International takes no position respecting the validity of any patent rights asserted in connection with any item mentioned in this standard. Users of this standard are expressly advised that determination of the validity of any such patent rights, and the risk of infringement of such rights, are entirely their own responsibility.*

*This standard is subject to revision at any time by the responsible technical committee and must be reviewed every five years and if not revised, either reapproved or withdrawn. Your comments are invited either for revision of this standard or for additional standards and should be addressed to ASTM International Headquarters. Your comments will receive careful consideration at a meeting of the responsible technical committee, which you may attend. If you feel that your comments have not received a fair hearing you should make your views known to the ASTM Committee on Standards, at the address shown below.*

*This standard is copyrighted by ASTM International, 100 Barr Harbor Drive, PO Box C700, West Conshohocken, PA 19428-2959, United States. Individual reprints (single or multiple copies) of this standard may be obtained by contacting ASTM at the above address or at 610-832-9585 (phone), 610-832-9555 (fax), or [service@astm.org](mailto:service@astm.org) (e-mail); or through the ASTM website ([www.astm.org](http://www.astm.org)). Permission rights to photocopy the standard may also be secured from the Copyright Clearance Center, 222 Rosewood Drive, Danvers, MA 01923, Tel: (978) 646-2600; <http://www.copyright.com/>*