



# Standard Practice for Installing Corrugated Aluminum Structural Plate Pipe for Culverts and Sewers<sup>1</sup>

This standard is issued under the fixed designation B789/B789M; the number immediately following the designation indicates the year of original adoption or, in the case of revision, the year of last revision. A number in parentheses indicates the year of last reapproval. A superscript epsilon ( $\epsilon$ ) indicates an editorial change since the last revision or reapproval.

## 1. Scope\*

1.1 This practice covers procedures, soils, and soil placement for the proper installation of corrugated aluminum structural plate culverts and sewers in either trench or embankment installations. A typical trench installation is shown in Fig. 1, and a typical embankment (projection) installation is shown in Fig. 2. Structural plate structures as described herein are those structures factory fabricated in plate form and bolted together on site to provide the required shape, size, and length of structure. This practice applies to structures designed in accordance with Practice B790/B790M.

1.2 The values stated in either inch-pound units or SI units are to be regarded separately as standard. Within the text, the SI units are shown in brackets. The values stated in each system are not exact equivalents; therefore, each system shall be used independently of the other. Combining values from the two systems may result in nonconformance with the standard.

1.3 *This standard does not purport to address all of the safety concerns, if any, associated with its use. It is the responsibility of the user of this standard to establish appropriate safety and health practices and determine the applicability of regulatory limitations prior to use.*

## 2. Referenced Documents

### 2.1 ASTM Standards:<sup>2</sup>

[B746/B746M Specification for Corrugated Aluminum Alloy Structural Plate for Field-Bolted Pipe, Pipe-Arches, and Arches](#)

[B790/B790M Practice for Structural Design of Corrugated Aluminum Pipe, Pipe-Arches, and Arches for Culverts, Storm Sewers, and Other Buried Conduits](#)

[D698 Test Methods for Laboratory Compaction Character-](#)

[istics of Soil Using Standard Effort \(12,400 ft-lbf/ft<sup>3</sup> \(600 kN-m/m<sup>3</sup>\)\)](#)

[D1556 Test Method for Density and Unit Weight of Soil in Place by Sand-Cone Method](#)

[D1557 Test Methods for Laboratory Compaction Characteristics of Soil Using Modified Effort \(56,000 ft-lbf/ft<sup>3</sup> \(2,700 kN-m/m<sup>3</sup>\)\)](#)

[D2167 Test Method for Density and Unit Weight of Soil in Place by the Rubber Balloon Method](#)

[D2487 Practice for Classification of Soils for Engineering Purposes \(Unified Soil Classification System\)](#)

[D2937 Test Method for Density of Soil in Place by the Drive-Cylinder Method](#)

[D6938 Test Methods for In-Place Density and Water Content of Soil and Soil-Aggregate by Nuclear Methods \(Shallow Depth\)](#)

## 3. Terminology

### 3.1 Definitions of Terms Specific to This Standard:

3.1.1 *arch*, *n*—segment of a circular shape spanning an open invert between the footings on which it rests.

3.1.2 *bedding*, *n*—earth or other material on which a pipe is supported.

3.1.3 *haunch*, *n*—portion of the pipe cross section between the maximum horizontal dimension and the top of the bedding.

3.1.4 *invert*, *n*—lowest point on the pipe cross section; also, the bottom portion of a pipe.

3.1.5 *pipe*, *n*—conduit having a full circular shape; also, in a general context, all structure shapes covered by this specification.

3.1.6 *pipe-arch*, *n*—pipe with an approximate semicircular crown, small-radius corners, and large-radius invert.

3.1.7 *underpass*, *n*—pipe with an approximate semicircular crown, large-radius sides, small-radius corners between sides and invert, and large-radius invert.

## 4. Significance and Use

4.1 Corrugated aluminum structural plate pipe functions structurally as a flexible ring that is supported by and interacts with the compacted surrounding soil. The soil placed around the structure is thus an integral part of the structural system. It

<sup>1</sup> This practice is under the jurisdiction of ASTM Committee B07 on Light Metals and Alloys and is the direct responsibility of Subcommittee B07.08 on Corrugated Aluminum Pipe and Corrugated Aluminum Structural Plate.

Current edition approved May 1, 2016. Published May 2016. Originally approved in 1988. Last previous edition approved in 2011 as B789/B789M – 99 (2011). DOI: 10.1520/B0789\_B0789M-16.

<sup>2</sup> For referenced ASTM standards, visit the ASTM website, [www.astm.org](http://www.astm.org), or contact ASTM Customer Service at [service@astm.org](mailto:service@astm.org). For *Annual Book of ASTM Standards* volume information, refer to the standard's Document Summary page on the ASTM website.

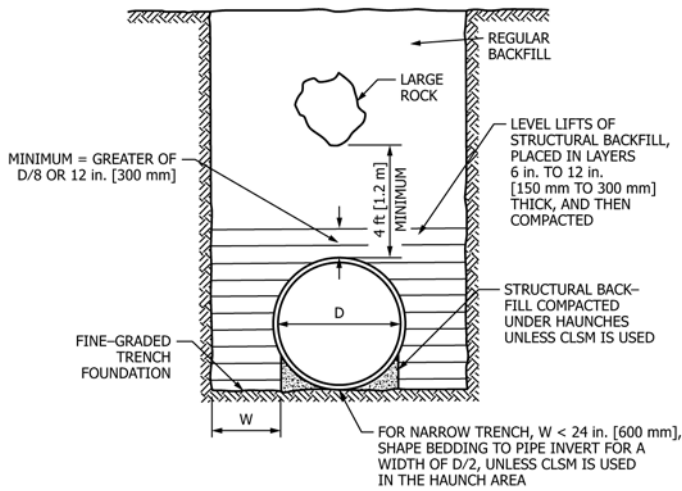

FIG. 1 Typical Trench Installation

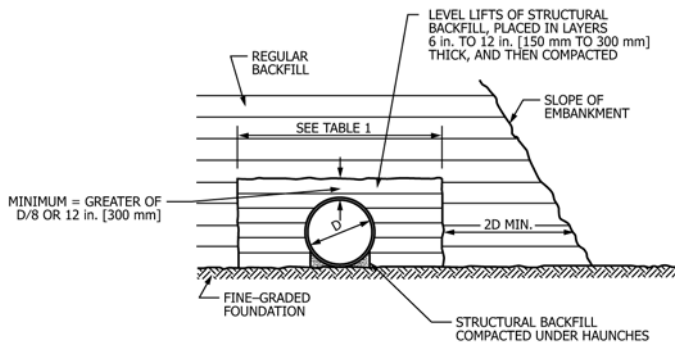

FIG. 2 Typical Embankment (Projection) Installation

is therefore important to ensure that the soil structure is made up of the acceptable material and well-constructed. Field verification of soil structure acceptability using Test Methods D1556, D2167, D6938, or D2937, as applicable, and comparing the results with Test Methods D698 or D1557, in accordance with the specifications for each project, is the most reliable basis for installation of an acceptable structure. The required density and method of measurement are not specified by this practice but must be established in the specifications for each project.

## 5. Trench Excavation

5.1 To obtain the anticipated structural performance of structural plate structures, it is not necessary to control trench width beyond the minimum necessary for proper assembly of the structure and placement of the structural backfill. However, the soil on each side beyond the excavated trench must be able to support anticipated loads. When a construction situation calls for a relatively wide trench, it may be made as wide as required for its full depth, if so desired. However, trench excavation must be in compliance with any local, state, and federal codes and safety regulations.

## 6. Foundation

6.1 The supporting soil beneath the structure must provide a reasonably uniform resistance to the imposed load, both

longitudinally and laterally. Sharp variations in the foundation must be avoided. When rock is encountered, it must be excavated and replaced with soil. If the structure is to be placed on a continuous rock foundation, it will be necessary to provide a bedding of soil between the rock and the structure. See Fig. 3.

6.2 Lateral changes in foundation should never be such that the structure is firmly supported while the backfill on either side is not. When soft material is encountered in the foundation and must be removed to maintain the grade on the structure, then it must be removed, usually for a minimum of three structure widths. See Fig. 4. A smaller width of removal can sometimes be used if established by the engineer.

6.3 Performance of buried structures is enhanced by allowing the structure to settle slightly relative to the columns of earth alongside. Therefore, when significant settlement of the overall foundation is expected, it is beneficial to provide a yielding foundation under structural plate structures. A yielding foundation is one that allows the structure to settle vertically by a greater amount than the vertical settlement of the columns of earth alongside. It can usually be obtained by placing beneath the structure a layer of suitable thickness of compressible soil, less densely compacted than the soil alongside. This is particularly important on structures with relatively large-radius invert plates.

6.4 For all structures with relatively small-radius corner plates adjacent to large-radius invert plates (such as pipe-arches or underpass structures), excellent soil support must be provided adjacent to the small-radius corner plates by both the in-situ foundation and the structural backfill. See Fig. 4 and Fig. 5. A yielding foundation must be provided beneath the invert plates for such structures when soft foundation conditions are encountered.

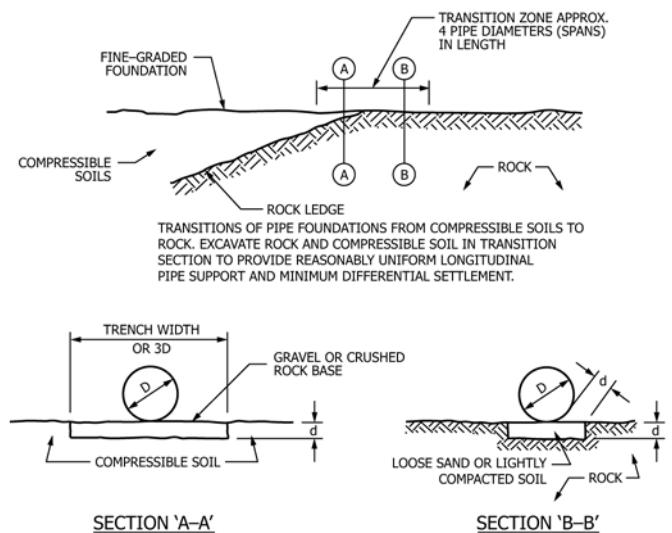

$d = 1/2$  in./ft [40 mm/m] of fill over pipe, with a 24-in. [600 mm] maximum  
NOTE: Section B-B is applicable to all continuous rock foundations

$d = 1/2$  in./ft. [40 mm/m] of fill over pipe, with a 24-in. [600 mm] maximum.  
NOTE 1—Section B-B is applicable to all continuous rock foundations

FIG. 3 Foundation Transition Zones and Rock Foundations

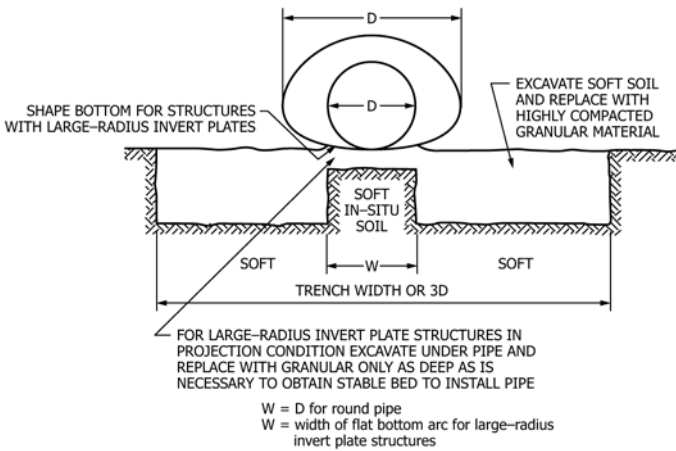

FIG. 4 Soft Foundation Treatment

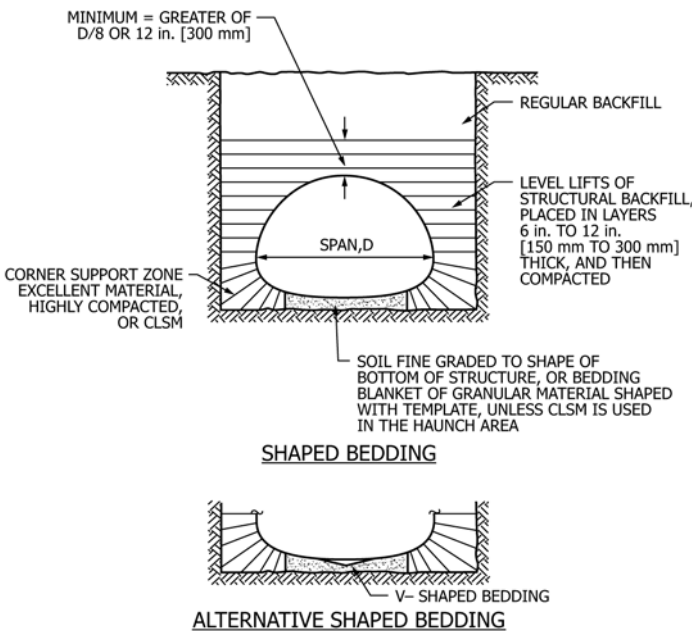

FIG. 5 Bedding and Corner Zone Treatment for Large-Radius Invert Plate Structures

## 7. Bedding

7.1 In most cases, structural plate structures may be assembled directly on in-situ material fine-graded to proper alignment and grade. Take care to compact the material beneath the haunches prior to placing structural backfill. For structures with relatively small-radius corner plates adjacent to large-radius invert plates, it is recommended to either shape the bedding to the invert plate radius or fine-grade the foundation to a slight v-shape. The soil adjacent to the corners must be of an excellent quality and highly compacted to accommodate the high reaction pressures that can develop at that location. See Fig. 5.

7.2 Structures having a span greater than 15 ft [4.5 m] or a depth of cover greater than 20 ft [6 m] should be provided with a shaped bedding on a yielding foundation. The bedding should be shaped to facilitate the required compaction of the structural backfill under the haunches. A shaped bedding on a yielding

foundation is always required under structures with small-radius corner plates adjacent to large-radius invert plates.

7.3 Material in contact with the pipe must not contain rock retained on a 3-in. [75-mm] diameter ring, frozen lumps, chunks of highly plastic clay, organic matter, corrosive material, or other deleterious material.

## 8. Assembly

8.1 Structural plate structures are furnished in components of plates and fasteners for field assembly. These components are furnished in accordance with Specification B746/B746M. Plates are furnished in a 4 ft, 6 in. [1372 mm] width and multiple lengths, preformed and punched for assembling into the required structure shape, size, and length. The plate lengths form the periphery of the structure. Arrange the single width and the multiple lengths to allow for staggered, transverse seams to avoid four-plate laps. The fabricator of the structural plate shall furnish an assembly drawing showing the location of each plate by width, length, thickness, and curvature. The plates must be assembled in accordance with the fabricator's drawing.

8.2 For structures with inverts, assembly shall begin with the invert plates at the downstream end. As the assembly proceeds upstream, plates that fall fully or partly below the maximum width of the structure are lapped over the preceding plates to construct the transverse seams.

### 8.3 Arches on Footings:

8.3.1 *Footings*—Arches have no integral invert and usually rest in key ways cast into footings. Key ways must be accurately set to span, line, and grade, as shown in the plans and specifications. When the arch is not a half circle, the key way must be angled (rotated) or sized to allow proper entrance of the plate. All pertinent dimensions must be shown on the drawings.

8.3.2 *Assembly*—For arch structures, assembly typically begins at the upstream end and proceeds downstream, with each succeeding plate lapping on the outside of the previous plate. There may be cases where it is more advantageous to start assembly at some other point along the length of the structure, such as is in the case where an elbow is involved. During the erection of the ring, plates are not self-supporting and must be temporarily supported. If the size of the key ways is such that the plates may move during backfilling, the plates must be temporarily blocked in the key ways to maintain span. Assemble as few plates as practical. Start with a row of several plates along both of the footings. Before finishing the bottom row of plates, start at the end of the structure with the next row of plates. Before reaching the end of the first row of plates, start again at the end of the structure with the next row of plates. Continue this process until the first ring is closed at its top, and then continue assembling all rows in this same manner. The structure will have a “stair step” appearance as a result of this procedure. This practice helps to hold the structure's shape.

8.4 Generally, structural plate should be assembled with as few bolts as practical. These bolts should be placed loose and remain loose until the periphery has been completed for several plate lengths. However, on large structures, it is practical to



align bolt holes during assembly and tighten the bolts to maintain structure shape. After the periphery of the structure is completed for several plate lengths, all bolts may be placed and tightened. Correct any significant deviation in the structure shape before tightening bolts (see Section 10). It is advisable not to tighten bolts on the loosely assembled structure within a distance of 30 ft [9 m] of where plate assembly is ongoing. All bolts shall be tightened using an applied torque of between 100 and 150 ft·lbf [135 and 205 N·m]. It is important not to over-torque the bolts.

8.5 Standard structural plate structures, because of the bolted construction, are not intended to be watertight. On occasions where a degree of watertightness is required, it is practical to introduce a seam sealant tape within the bolted seams. The tape shall be wide enough to effectively cover all rows of holes in plate laps, and of the proper thickness and consistency to effectively fill all voids in plate laps. General procedures for installing sealant tape are as follows: On longitudinal seams, prior to placing the lapping plate, roll the tape over the seam and work into the corrugations. Do not stretch the tape. Remove any paper backing prior to making up the joint. Seal transverse seams in a like manner with tape. At all points where three plates intersect, place an additional thickness of tape for a short distance to fill the void caused by the transverse seam overlap. It is most practical to punch the tape for bolts with a hot spud wrench or sharp tool. At least two tightenings of the bolts will usually be necessary to accomplish the required torque.

## 9. Structural Backfill Material

9.1 Structural backfill is that material that surrounds the pipe, extending laterally to the walls of the trench or to the fill material for embankment construction, and extending vertically from the invert to an elevation of 1 ft [300 mm] or 1/8 the span, whichever is greater, over the pipe. The necessary width of structural backfill depends on the quality of the trench wall or embankment material, the type of material and compaction equipment used for the structural backfill, and in embankment construction, the type of construction equipment used to compact the embankment fill. The width of structural backfill shall meet the requirements given in Table 1.

9.2 Structural backfill material shall be readily compacted soil or granular fill material. Structural backfill may be excavated native material, when suitable, or select material. Select material such as bank-run gravel, or other processed granular materials (not retained on a 3-in. [75-mm] diameter ring) with excellent structural characteristics, is preferred. Desired end results can be obtained with such material with a minimum of compactive effort over a wide range of moisture content, lift depths, and compaction equipment. Soil used as structural backfill must not contain rock retained on a 3-in. [75-mm] diameter ring, frozen lumps, highly plastic clays, organic matter, corrosive material, or other deleterious foreign matter. Soil classifications are defined in Classification D2487. Acceptable soils include Groups GW, GP, GM, GC, SW, and SP, when compacted to the specified percent of maximum density, as determined by Test Methods D698 or D1557, using Test Methods D1556, D2167, D6938, or D2937. Soil types SM and

**TABLE 1 Structural Backfill Width Requirements<sup>A,B</sup>**

Adjacent Material	Required Structural Backfill Width
Normal highway embankment compacted to minimum of 90 % Test Methods D698 density, or equivalent trench wall.	As needed to establish pipe bedding and to place and compact the backfill in the haunch area and beside the pipe. Where backfill materials that do not require compaction are used, such as cement slurry or controlled low strength material (CLSM), a minimum of 3 in. [75 mm] on each side of the pipe is required.
Embankment or trench wall of lesser quality.	Increase backfill width as necessary to reduce horizontal pressure from pipe to a level compatible with bearing capacity of adjacent materials.

<sup>A</sup> For pipe arches and other multiple radius structures, as well as for all structures carrying off-road construction equipment, the structural backfill width, including any necessary foundation improvement materials, must be sufficient to reduce the horizontal pressure from the structure so that it does not exceed the bearing capacity of the adjacent material.

<sup>B</sup> In embankment construction, the structural backfill width must be adequate to resist forces caused by the embankment construction equipment. Generally, the width on each side of the pipe should be no less than 2 ft [600 mm] for spans that do not exceed 12 ft [3.6 m], or 3 ft [900 mm] for greater spans.

SC are acceptable but may require closer control to obtain the specified density. Soil groups ML and CL are not preferred materials, while soil groups OL, MH, CH, OH, and PT are not acceptable.

## 10. Shape Control

10.1 Excessive compaction, unbalanced loadings, loads from construction equipment, as well as inadequate compaction or poor structural backfill materials, can cause excessive pipe distortion. For larger pipe, the construction contractor may set up a shape monitoring system, prior to placement of structural backfill, to aid in establishing and maintaining proper installation procedures. Such a system is particularly desirable for structures having a span greater than 20 ft [6 m]. Direct measurement of span and rise, offset measurements from plumb bobs hanging over reference points, and use of surveying instruments are effective means for monitoring shape change during structural backfill placement and compaction. The final installed shape must be within the design criteria, exhibit smooth uniform radii, and provide acceptable clearances for its intended use. In general, it is desirable for the crown of the pipe to rise slightly, in a balanced concentric manner, during placement and compaction of structural backfill beside the pipe. Under the load of the completed fill and the service load, vertical deflections will be a small percentage of the pipe rise dimension if structural backfill compaction is adequate. Structures having a span greater than 20 ft [6 m] should be within 2 % of the calculated dimensions as given in Specification B746/B746M prior to structural backfill placement.

## 11. General Placement of Structural Backfill

11.1 Structural backfill should be placed by moving equipment longitudinally, parallel to the structure centerline, rather than at right angles to the structure. Material must not be dumped directly on or against the structure. In embankment installations, heavy compaction equipment should stay at least 4 ft [1.2 m] away from the structure. In trench installations, the width of the trench will dictate the type of compaction

equipment. Heavy construction equipment must not be operated over the structure without adequate protective cover. Adequate cover depends on the structure size and structural backfill placement, and must be determined by the engineer. Depending on the type of material and compaction equipment or method used, place the structural backfill in 6 to 12-in. [150 to 300-mm] lifts or layers before compaction. Each lift must be compacted before the next lift is placed. The difference in the depth of structural backfill on opposite sides of the structure should not be greater than 2 ft [600 mm]. The compacted structural backfill should usually be placed to 0.75 the height of the structure before covering the crown. However, structural backfill may be placed on the crown whenever required to control the structure shape. A layer of structural backfill (to a depth of 1 ft [300 mm] or one-eighth the span, whichever is greater) should be placed over the crown before introduction of regular backfill.

11.2 The compaction of structural backfill shall provide a soil structure around the pipe to uniformly apply overburden on the crown of the structure and provide adequate uniform bearing for the structure side walls and haunches. For relatively shallow buried structures, under no live loads, acceptable structural backfill and the degree of compaction may be determined by the character of the total installation. The structural backfill is, however, an integral part of the structural system. Therefore, required end results regarding material type and in-place density of the structural backfill must be in accordance with project specifications.

11.3 When cohesive soils are used for structural backfill, good compaction can be obtained only at proper moisture content. Shallower lifts are usually necessary with cohesive soils than with granular materials to arrive at acceptable in-place density. Mechanical compaction effort should be used with all cohesive soils. Mechanical soil compaction in layers is generally preferred. However, when acceptable end results can be achieved with water consolidation, it may be used. When water methods are used, care must be taken to prevent flotation. Water methods can be used only on free-draining structural backfill material. The structural backfill and adjacent soil must be sufficiently permeable to dispose of the excess water. Water consolidation is not acceptable with cohesive soils.

11.4 *Pipe-Arches*—Special attention must be given to materials used and compaction obtained around the corners of pipe-arches. At the corners of all structures with small-radius haunch plates, the structural backfill must be well-compacted, particularly for those structures under significant loads. For structures with large spans or heavy loads, special design of the structural backfill may be required for the corner plate zone. See Fig. 4 and Fig. 5.

11.5 *Arches*—Placement procedures for structural backfill for arches deviates from that for other structures. The desired procedure is to place fill material in lifts evenly on both sides of the structure to construct a narrow envelope over the crown. Compact each lift as the envelope is constructed. Take care not to distort the arch. Continue to build structural backfill away from the original envelope maintaining sufficient load on the crown to limit peaking as the side fill is compacted.

11.6 Generally, construction experience and a site appraisal will establish the most economical combination of material, method, and equipment to yield acceptable end results. Measurement of soil density in accordance with Test Methods D698 or D1557 are usually the preferred means of determining maximum (standard) density and optimum moisture content. A construction procedure must then be established that will result in the specified percent of maximum density. Once a procedure is established, the primary inspection effort should be directed at ensuring that the established procedure is followed. Such procedure may involve material, depth of lift, moisture content, and compactive effort. Only occasional checks of soil density may then be required, as long as the material and procedures are unchanged. In-situ density may be determined by Test Methods D1556, D2167, D6938, or D2937, as applicable, for field verification. Testing should be conducted on both sides of the structure. Any construction methods and materials that achieve the required end results in the completed structural backfill, without damage to or distortion of the structure, are acceptable. Unless project specifications provide other limits, the soil should be compacted to a minimum of 90 % density in accordance with Test Method D698.

## 12. Regular Backfill

12.1 Regular backfill in trench installations is that material placed in the trench above the structural backfill. In embankment installations, regular backfill is that material, outside the limits of the structural backfill. Regular backfill usually consists of native materials placed in accordance with project specifications. Large boulders must not be permitted in regular backfill in trenches that are under surface loads and never within 4 ft [1.2 m] of the structure (see Fig. 1).

## 13. Multiple Structures

13.1 When two or more structures are installed in adjacent lines, the minimum spacing requirements given in Practice B790/B790M must be provided.

## 14. Keywords

14.1 aluminum pipe; culvert; installation—underground; sewers; structural plate pipe

**SUMMARY OF CHANGES**

Committee **B07** has identified the location of selected changes to this standard since the last issue (B789/B789M – 05 (2011)) that may impact the use of this standard. (Approved May 1, 2016.)

(1) Removed Test Methods D2922 from Section 2.

(2) Added Test Methods **D6938** to Section 2

*ASTM International takes no position respecting the validity of any patent rights asserted in connection with any item mentioned in this standard. Users of this standard are expressly advised that determination of the validity of any such patent rights, and the risk of infringement of such rights, are entirely their own responsibility.*

*This standard is subject to revision at any time by the responsible technical committee and must be reviewed every five years and if not revised, either reapproved or withdrawn. Your comments are invited either for revision of this standard or for additional standards and should be addressed to ASTM International Headquarters. Your comments will receive careful consideration at a meeting of the responsible technical committee, which you may attend. If you feel that your comments have not received a fair hearing you should make your views known to the ASTM Committee on Standards, at the address shown below.*

*This standard is copyrighted by ASTM International, 100 Barr Harbor Drive, PO Box C700, West Conshohocken, PA 19428-2959, United States. Individual reprints (single or multiple copies) of this standard may be obtained by contacting ASTM at the above address or at 610-832-9585 (phone), 610-832-9555 (fax), or [service@astm.org](mailto:service@astm.org) (e-mail); or through the ASTM website ([www.astm.org](http://www.astm.org)). Permission rights to photocopy the standard may also be secured from the Copyright Clearance Center, 222 Rosewood Drive, Danvers, MA 01923, Tel: (978) 646-2600; <http://www.copyright.com/>*