



# Standard Test Method for Measuring and Recording the Deviations from Flatness in Copper and Copper Alloy Strip<sup>1</sup>

This standard is issued under the fixed designation B754; the number immediately following the designation indicates the year of original adoption or, in the case of revision, the year of last revision. A number in parentheses indicates the year of last reapproval. A superscript epsilon ( $\epsilon$ ) indicates an editorial change since the last revision or reapproval.

<sup>ε1</sup> NOTE—Editorial changes were made in 1.1, 1.5 and 2.1 in May 2015.

## 1. Scope\*

1.1 This test method establishes a procedure for the measurement of distortions in thin metal strip and the application of these measurements to an equation that will indicate the deviation from flatness.

1.2 The distortions to be measured in this test method are dish, wavy edges, buckle, longitudinal corrugation, and herringbone.

1.3 This test method is not intended to include the measurement of coil set or longitudinal curl, camber or edgewise curvature, or twist.

1.4 This test method is limited to metal strip 0.003 to 0.020 in. (0.08 to 0.50 mm) thick and not more than 6.0 in. (150.0 mm) wide.

1.5 *Units*—The values stated in inch-pound units are to be regarded as standard. The values given in parentheses are mathematical conversions to SI units which are provided for information only and are not considered standard.

1.6 The following safety hazard caveat pertains only to the test method(s) described in this test method. *This standard does not purport to address all of the safety concerns, if any, associated with its use. It is the responsibility of the user of this standard to establish appropriate safety and health practices and determine the applicability of regulatory limitations prior to use.*

## 2. Referenced Documents

2.1 *ASTM Standards*:<sup>2</sup>

**B846 Terminology for Copper and Copper Alloys**

<sup>1</sup> This test method is under the jurisdiction of ASTM Committee B05 on Copper and Copper Alloys and is the direct responsibility of Subcommittee B05.06 on Methods of Test.

Current edition approved May 1, 2015. Published May 2015. Originally approved in 1986. Last previous edition approved 2010 as B754 – 10. DOI: 10.1520/B0754-10R15E01.

<sup>2</sup> For referenced ASTM standards, visit the ASTM website, www.astm.org, or contact ASTM Customer Service at service@astm.org. For *Annual Book of ASTM Standards* volume information, refer to the standard's Document Summary page on the ASTM website.

**B950 Guide for Editorial Procedures and Form of Product Specifications for Copper and Copper Alloys**

## 3. Terminology

3.1 For determination of terms relating to copper and copper alloys, refer to Terminology **B846**.

3.2 *Definitions of Terms Specific to This Standard*:

3.2.1 *edge wave* (see *wavy edge*), *n*—a continuous pattern of waves or wrinkles along the edges of the strip, with a relatively flat center portion.

## 4. Summary of Test Method

4.1 A prepared test specimen of a specific wrought copper or copper alloy sheet or strip of a predetermined thickness is placed on a surface plate. The relative flatness of the sample is determined by measuring length and height of the irregularity and calculating percent of deviation.

## 5. Significance and Use

5.1 This test method is intended for measuring distortion in strip used for making close tolerance parts. Since distortion in this strip would influence the shape of the part being produced and cause difficulties in feeding through close-fitting dies and other manufacturing equipment, it is important that this material be flat.

5.2 This test method provides a universal procedure for measuring the irregularities that cause the deviation from flatness.

5.3 This test method allows the purchaser and manufacturer to inspect strip with a standard technique to a mutually agreed upon and acceptable percentage deviation from flatness.

## 6. Apparatus

6.1 *Surface Plate*, to be used as a reference flat. It must have a large enough surface area to accommodate the maximum size test specimen. It shall be flat within 0.0002 in. (0.005 mm) per 1 in. (25 mm).

6.2 *Micrometer*, for measuring metal thickness. It shall be graduated in 0.0001-in. (0.0025-mm) increments.

\*A Summary of Changes section appears at the end of this standard

6.3 *Height Gage*, for measuring the height of irregularities. The arm of this gage must be long enough to extend beyond the center of the widest strip to be measured. It shall be graduated in 0.001-in. (0.025-mm) increments.<sup>3</sup>

6.4 *Steel Rule*, for measuring the lengths of the irregularities. It shall be graduated in 0.02-in. (0.50-mm) increments.

## 7. Test Specimens

7.1 The test specimen shall be the full-finished slit width of the strip and cut long enough so that measurement will not be influenced by the distortions referred to in 1.3.

7.2 When cutting specimens, caution must be taken to prevent additional distortion.

## 8. Procedure

8.1 Measure the thickness of the specimen at six locations, near each corner and at midwidth at each end, to the nearest 0.001 in. (0.03 mm) using the micrometer. The average of these six readings will be used as *T*.

8.2 Place the test strip unrestrained on the surface plate. If the specimen is not flat, compare the irregularities observed with the illustrations shown in Figs. 1-5 to determine the type of distortion and how it should be measured.

8.3 Using the height gage, measure the highest point *H* of each of the irregularities to the nearest 0.001 in. (0.03 mm). See Figs. 1-6.

8.4 Using the steel rule, measure the length *L* between the points where the outer radii of the most significant irregularity touches the surface plate, to the nearest 0.02 in. (0.50 mm). See Figs. 1-7.

<sup>3</sup> An electronic touch sensitive system, which will not distort the sample, has been found to be acceptable.

8.5 Repeat this procedure as often as necessary to satisfy quality level requirements, recording each measurement.

## 9. Calculation or Interpretation of Results

9.1 Apply the values for *T*, *H*, and *L* obtained for each irregularity to the following equation to determine the percentage of deviation from flat.

$$\text{Deviation from flat, \%} = \frac{H - T}{L} \times 100 \quad (1)$$

Compare the results to the agreed upon limits. The larger the percentage, the greater the deviation from flat.

## 10. Report

10.1 The nominal thickness, width, temper, alloy number, and form of product should be reported.

10.2 The number and type of distortions measured and the thickness, height, length, and percent deviation from flatness for each should be reported.

## 11. Precision and Bias

11.1 The precision of this test method is dependent upon the sensitivity of the measuring apparatus.

11.2 This test method has no bias because the values of deviation from flatness are direct measurements based on the accuracy of the test apparatus and the observations of the inspector.

## 12. Keywords

12.1 edge wave; flatness measurement; strip distortion; strip flatness; wavy edge

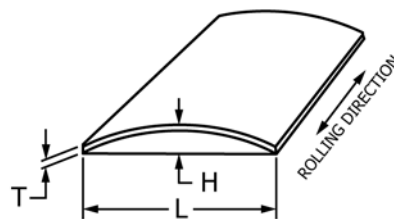

FIG. 1 Dish

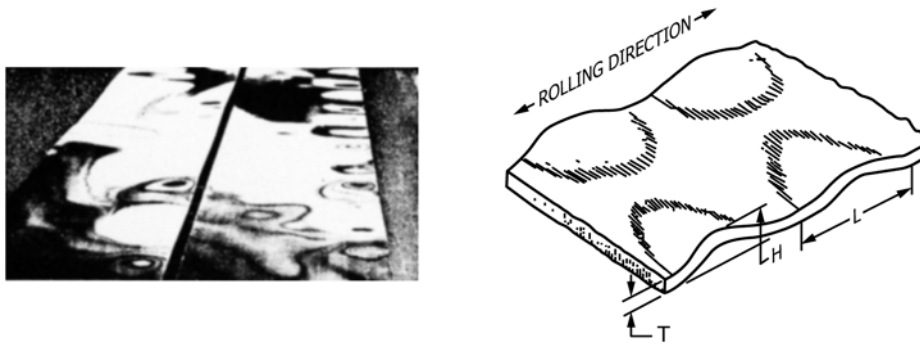
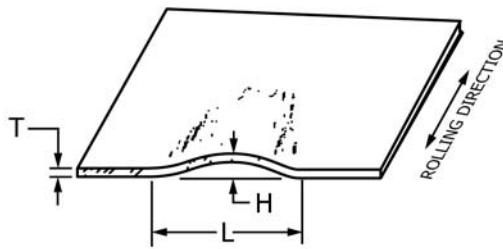
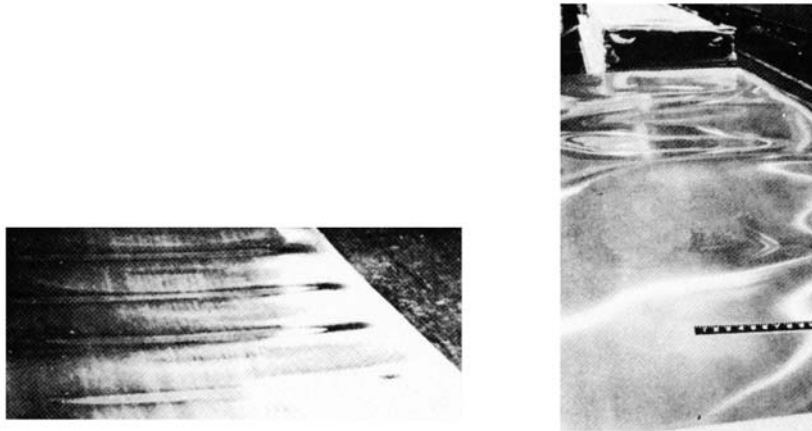

FIG. 2 Wavy Edges



NOTE 1—For illustration only. Section to show measuring.

FIG. 3 Buckle

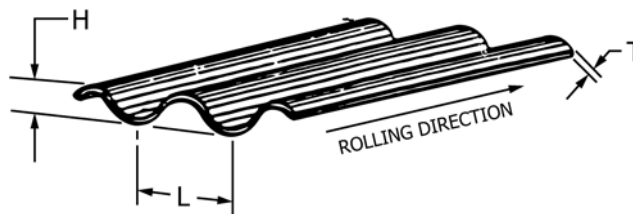

FIG. 4 Longitudinal Corrugation



FIG. 5 Herringbone

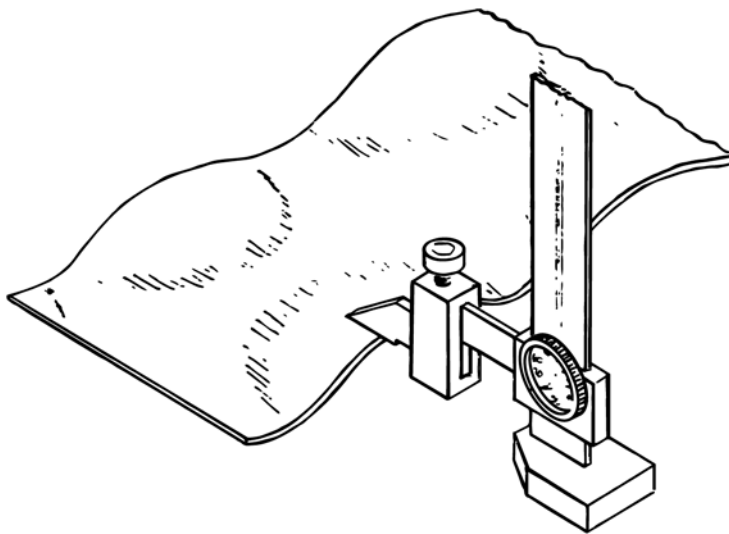

FIG. 6 Measuring Height of Irregularity With Height Gage

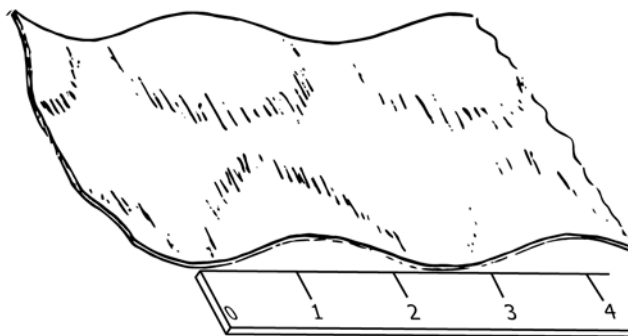

FIG. 7 Measuring Length of Irregularity With Steel Rule

**SUMMARY OF CHANGES**

Committee B05 has identified the location of selected changes to this standard since the last issue (B754 - 10) that may impact the use of this standard. (Approved May 1, 2015.)

(1) This test method was reviewed and revised to comply with the selected wording in Guide **B950**.

*ASTM International takes no position respecting the validity of any patent rights asserted in connection with any item mentioned in this standard. Users of this standard are expressly advised that determination of the validity of any such patent rights, and the risk of infringement of such rights, are entirely their own responsibility.*

*This standard is subject to revision at any time by the responsible technical committee and must be reviewed every five years and if not revised, either reapproved or withdrawn. Your comments are invited either for revision of this standard or for additional standards and should be addressed to ASTM International Headquarters. Your comments will receive careful consideration at a meeting of the responsible technical committee, which you may attend. If you feel that your comments have not received a fair hearing you should make your views known to the ASTM Committee on Standards, at the address shown below.*

*This standard is copyrighted by ASTM International, 100 Barr Harbor Drive, PO Box C700, West Conshohocken, PA 19428-2959, United States. Individual reprints (single or multiple copies) of this standard may be obtained by contacting ASTM at the above address or at 610-832-9585 (phone), 610-832-9555 (fax), or [service@astm.org](mailto:service@astm.org) (e-mail); or through the ASTM website ([www.astm.org](http://www.astm.org)). Permission rights to photocopy the standard may also be secured from the Copyright Clearance Center, 222 Rosewood Drive, Danvers, MA 01923, Tel: (978) 646-2600; <http://www.copyright.com/>*