



Standard Specification for Tantalum and Tantalum Alloy Plate, Sheet, and Strip¹

This standard is issued under the fixed designation B708; the number immediately following the designation indicates the year of original adoption or, in the case of revision, the year of last revision. A number in parentheses indicates the year of last reapproval. A superscript epsilon (ϵ) indicates an editorial change since the last revision or reapproval.

1. Scope

1.1 This specification covers unalloyed and alloyed tantalum plate, sheet, and strip as follows.

1.1.1 R05200, unalloyed tantalum, electron-beam furnace or vacuum-arc melt, or both,

1.1.2 R05400, unalloyed tantalum, powder-metallurgy consolidation,

1.1.3 R05255, tantalum alloy, 90 % tantalum, 10 % tungsten, electron-beam furnace or vacuum-arc melt, or both,

1.1.4 R05252, tantalum alloy, 97.5 % tantalum, 2.5 % tungsten, electron-beam furnace or vacuum-arc melt, or both, and

1.1.5 R05240, tantalum alloy, 60 % tantalum, 40 % niobium, electron-beam furnace or vacuum-arc melt.

1.2 The values stated in inch-pound units are to be regarded as standard. The values given in parentheses are mathematical conversions to SI units that are provided for information only and are not considered standard.

1.3 *This standard does not purport to address all of the safety and/or health problems, if any, associated with its use. It is the responsibility of the user of this standard to establish appropriate safety and health practices and determine the applicability of regulatory limitations prior to use.*

2. Referenced Documents

2.1 *ASTM Standards:*²

[E8 Test Methods for Tension Testing of Metallic Materials](#)

[E29 Practice for Using Significant Digits in Test Data to Determine Conformance with Specifications](#)

[E112 Test Methods for Determining Average Grain Size](#)

3. Terminology

3.1 *Definitions of Terms Specific to This Standard:*

¹ This specification is under the jurisdiction of ASTM Committee B10 on Reactive and Refractory Metals and Alloys and is the direct responsibility of Subcommittee B10.03 on Niobium and Tantalum.

Current edition approved Dec. 1, 2012. Published January 2013. Originally approved in 1982. Last previous edition approved in 2005 as B708 – 05. DOI: 10.1520/B0708-12.

² For referenced ASTM standards, visit the ASTM website, www.astm.org, or contact ASTM Customer Service at service@astm.org. For *Annual Book of ASTM Standards* volume information, refer to the standard's Document Summary page on the ASTM website.

3.1.1 *annealed material, n*—plate, sheet, or strip that has been annealed.

3.1.2 *annealing (annealed), n*—the act of heat treating to soften plate, sheet, or strip.

3.1.3 *lot, n*—all material produced from the same ingot or a single powder blend at one time with the same cross section, and with the same nominal metallurgical parameters.

3.1.4 *plate, n*—a flat product more than 0.1853 in. (4.7 mm) in thickness.

3.1.5 *sheet, n*—a flat product 6 in. (152.4 mm) or more in width and from 0.005 in. (0.13 mm) to 0.1875 in. (4.76 mm) in thickness.

3.1.6 *strip, n*—a flat product, may be supplied in coil, less than 6 in. (152.4 mm) in width and from 0.005 in. (0.13 mm) to 0.1875 in. (4.76 mm) in thickness.

4. Classifications

4.1 The strip, sheet or plate is to be furnished in the following grades:

4.1.1 R05200, unalloyed tantalum, electron-beam furnace or vacuum-arc melted, or both,

4.1.2 R05400, unalloyed tantalum, powder-metallurgy consolidation,

4.1.3 R05255, tantalum alloy, 90 % tantalum, 10 % tungsten, electron-beam furnace or vacuum-arc melted, or both,

4.1.4 R05252, tantalum alloy, 97.5 % tantalum, 2.5 % tungsten, electron-beam furnace or vacuum-arc melted, or both,

4.1.5 R05240, tantalum alloy, 60 % tantalum, 40 % niobium, electron-beam furnace or vacuum-arc melted, or both.

4.1.6 For sputtering application see supplemental requirements to grades R05200 and R05400.

5. Ordering Information

5.1 Orders for material under this specification shall include the following information as applicable:

5.1.1 Quantity (weight, number of pieces or other suitable measure of quantity),

5.1.2 Name of material (tantalum plate, sheet, or strip),

5.1.3 Grade (alloy and method of manufacture) (see 4.1.1 – 4.1.6),

5.1.4 ASTM Standard (Specification B708) and year of issue, and

5.1.5 Additions to the specification and supplementary requirements if required.

6. Materials and Manufacture

6.1 Material covered by this specification shall be made from vacuum-arc melted or electron-beam melted ingots or powder metallurgy consolidated unalloyed tantalum.

6.2 The various tantalum mill products covered by this specification are formed with the conventional extrusion, forging, and rolling equipment normally available in metal working plants.

6.3 All material shall be supplied in the annealed condition unless otherwise specified by the purchaser.

6.3.1 If specified on the purchase order, the material can be supplied in the “fully recrystallized” condition. In this case the plate, sheet, strip, or foil shall be 90 % minimum recrystallized as measured in accordance with 16.3. The terms “fully annealed,” “completely,” and other similar terms shall be considered the same as “fully recrystallized.”

7. Chemical Composition

7.1 The tantalum and tantalum alloy ingots and the tantalum powder metallurgy consolidated ingots for conversion to finished products covered by this specification shall conform to the requirements for chemical composition as prescribed in Table 1.

7.1.1 Analysis for elements not listed in Table 1 and not normally expected in tantalum shall not be required unless specified at time of purchase.

7.2 The manufacturer’s ingot (or powder metallurgy consolidated bar) analysis may be considered the chemical analysis for products supplied under this specification. Alternately, an analysis of a representative sample of in-process material (or the final product) from the same ingot may be substituted.

7.3 When requested by the purchaser at the time of purchase, the seller shall furnish a report certifying the values of carbon, oxygen, nitrogen, and hydrogen of the finished

product as specified in Table 2 for each lot of material supplied. The performance of this special provision shall be negotiated.

8. Mechanical Properties

8.1 Annealed materials supplied under this specification shall conform to the requirements for mechanical properties as specified in Table 3. No mechanical property requirements for unannealed (not heat treated) plate, sheet, or strip have been established by this specification. Unless otherwise specified, material supplied under this specification will be supplied in the annealed condition.

9. Metallurgical Properties

9.1 Unless otherwise stated, the materials supplied under these specifications shall be in the fully annealed condition.

9.2 Other conditions, such as cold-worked or stress-relieved, can be specified as agreed upon between the purchaser and the manufacturer at the time of the purchase.

10. Special Requirements

10.1 None specified.

11. Significance of Numerical Limits

11.1 For the purpose of determining compliance with the specified limits for requirements of the properties listed in the following table, an observed value or a calculated value shall be rounded as indicated in accordance with the rounding methods of Practice E29.

Property	Rounded Unit for Observed or Calculated Value
Chemical composition, and tolerances (when expressed as decimals)	nearest unit in the last right-hand place of figures of the specified limit
Tensile strength and yield strength	nearest 1000 psi (10 MPa)
Elongation	nearest 1 %

12. Permissible Variations in Dimensions

12.1 *Thickness*—The variation in thickness of strip, sheet, and plate is given in the following table:

12.1.1 Plate, Sheet and Strip, Table 4.

TABLE 1 Chemical Requirements

Element	Content, max, weight %				
	Electron-Beam Cast (R05200) Vacuum-Arc Cast (R05200) Unalloyed Tantalum	Sintered (R05400) Unalloyed Tantalum	Electron-Beam Cast (R05255) Vacuum-Arc Cast (R05255) 90 % Tantalum 10 % Tungsten	Electron-Beam Cast (R05252) Vacuum-Arc Cast (R05252) 97.5 % Tantalum 2.5 % Tungsten	Electron Beam Cast (R05240) Vacuum-Arc Cast (R05240) 60 % Tantalum 40 % Niobium
C	0.010	0.010	0.010	0.010	0.010
O	0.015	0.03	0.015	0.015	0.020
N	0.010	0.010	0.010	0.010	0.010
H	0.0015	0.0015	0.0015	0.0015	0.0015
Fe	0.010	0.010	0.010	0.010	0.010
Mo	0.020	0.020	0.020	0.020	0.020
Nb	0.100	0.100	0.100	0.50	35.0–42.0
Ni	0.010	0.010	0.010	0.010	0.010
Si	0.005	0.005	0.005	0.005	0.005
Ti	0.010	0.010	0.010	0.010	0.010
W	0.05	0.05	9.0–11.0	2.0–3.5	0.050
Ta	remainder	remainder	remainder	remainder	remainder

TABLE 2 Additional Chemical Requirements for Finished Product (When Specified by the Purchaser)

Element	Content, max, weight %				
	Electron-Beam Cast (R05200) Vacuum-Arc Cast (R05200) Unalloyed Tantalum	Sintered (R05400) Unalloyed Tantalum	Electron-Beam Cast (R05255) Vacuum-Arc Cast (R05255) 90 % Tantalum 10 % Tungsten	Electron-Beam Cast (R05252) Vacuum-Arc Cast (R05252) 97.5 % Tantalum 2.5 % Tungsten	Electron Beam Cast (R05240) Vacuum-Arc Cast (R05240) 60 % Tantalum 40 % Niobium
O	0.025	0.035	0.025	0.025	0.025
N	0.010	0.010	0.010	0.010	0.010
H	0.0015	0.0015	0.0015	0.0015	0.0015
C	0.020	0.020	0.020	0.020	0.020

TABLE 3 Mechanical Properties for Annealed Plate, Sheet, and Strip

Grade and Form	Annealed Condition		
	Ultimate Tensile Strength, min, psi (MPa)	Yield Strength, min, psi (MPa) (2 % Offset)	Elongation, min, % (1-in. Gage Length)
Unalloyed tantalum (R05200) (R05400) Plate, sheet and strip	<0.060 in. thick	30 000 (207)	20
	≥0.060 in. thick	25 000 (172)	30
90 % tantalum – 10 % tungsten (R05255) Sheet and strip	Sheet	70 000 (482)	15
	Strip	70 000 (482)	20
97.5 % tantalum – 2.5 % tungsten (R05252) Plate	<0.125 in. thick	40 000 (276)	20
	≥0.125 in. thick	40 000 (276)	25
60 % tantalum – 40 % niobium (R05240) Plate	<0.060 in. thick	35 000 (241)	25
	≥0.060 in. thick	35 000 (241)	25

TABLE 4 Dimensional Tolerances for Tantalum Sheet and Plate

Thickness of Tantalum in. (mm)	Tolerance on Thickness, ^A plus or minus, in. (mm)		Tolerance on Width (Slit), ^B plus or minus, in. (mm)		Tolerance on Sheared Lengths, in. (mm)			
	Width under 6 in. (152.4 mm)	Width 6 to 24 in. (152.4 to 609.6 mm)	Width under 6 in. (152.4 mm)	Width 6 to 24 in. (152.4 to 609.6 mm)	Length 12 in. (304.8 mm) and Under		Length over 12 in. (304.8 mm)	
					Plus	Minus	Plus	Minus
0.0051 to 0.010 (0.129 to 0.254)	0.0005 (0.0127)		0.012 (0.305)		1/16 (1.59)	0	1/4 (6.35)	0
0.011 to 0.015 (0.279 to 0.381)	0.0007 (0.0178)	0.001 (0.0254)	0.015 (0.381)	0.015 (0.381)	1/16 (1.59)	0	1/4 (6.35)	0
0.016 to 0.020 (0.406 to 0.508)	0.0008 (0.0203)	0.0015 (0.0381)	0.015 (0.381)	0.015 (0.381)	1/16 (1.59)	0	1/4 (6.35)	0
0.021 to 0.030 (0.533 to 0.762)	0.0015 (0.0381)	0.0025 (0.0635)	0.020 (0.508)	0.025 (0.635)	1/16 (1.59)	0	1/4 (6.35)	0
0.031 to 0.060 (0.787 to 1.524)	0.0025 (0.0635)	0.0035 (0.0889)	0.025 (0.635)	0.030 (0.762)	1/16 (1.59)	0	1/4 (6.35)	0
0.061 to 0.090 (1.549 to 2.286)	0.004 (0.1016)	0.005 (0.1270)	0.025 (0.635)	0.035 (0.889)	1/16 (1.59)	0	1/4 (6.35)	0
0.091 to 0.125 (2.311 to 3.175)	0.006 (0.1524)	0.007 (0.1778)	1/16 (1.59)	0	1/4 (6.35)	0
0.126 to 0.187 (3.200 to 4.750)	0.010 (0.2540)	0.010 (0.2540)	1/16 (1.59)	0	1/4 (6.35)	0

^A Tolerance on thickness of sheet over 24 in. (609.6 mm) wide shall be ±10 % of the thickness.

^B Tolerance on width of sheared sheet shall be + 1/4 in. (6.35 mm), – 0 in. (0 mm).

12.2 *Width*—The variation in width is give in the following table:

12.2.1 Plate, Sheet and Strip, [Table 4](#).

12.3 *Length*—The variation in length is given in the following table:

12.3.1 Plate, Sheet and Strip, [Table 4](#).

12.4 *Flatness*—The permissible variation from a flat surface.

12.4.1 The flatness tolerance for sheet and plate products supplied under this specification shall be a maximum of 6 % as determined by the procedure in Fig. 1.

12.5 *Quantity or Weight:*

12.5.1 For orders requiring up to 100 lb (45.4 kg), the manufacturer may overship by 10 %. When the order is for guarantees up to 500 lb (226.8 kg), the manufacturer may overship an order by 5 %. The permissible overshipment for quantities larger than this shall be negotiated between the purchaser and the manufacturer.

13. Condition and Finish

13.1 None specified.

14. Workmanship and Appearance

14.1 Cracks, seams, slivers, blisters, burrs, and other injurious imperfections shall not exceed standards of acceptability agreed upon by the manufacturer and the purchaser.

14.2 Finished strip, sheet, and plate shall be free of injurious internal and external imperfections of a nature that will interfere with the purpose for which it was intended.

14.3 The finished strip, sheet, or plate shall be visibly free of oxide, grease, oil, residual lubricants, and other extraneous materials.

14.4 Methods of testing for these defects and standards of acceptability shall be as agreed upon between the manufacturer and the purchaser.

14.5 The manufacturer shall be permitted to remove surface imperfections provided such removal does not reduce any dimension below the minimum permitted by the tolerances for that dimension.

15. Number of Tests and Results

15.1 Unless otherwise specified one sample per lot shall be sufficient for conformance to this specification.

15.2 If mechanical testing is required (see 8.1), perform a longitudinal or transverse tension test on each lot of material.

15.3 If end-product chemical tests are required (see 7.3), one chemical test from each lot of finished product shall be performed.

15.4 If any sample or specimen exhibits obvious surface contamination or improper preparation, disqualifying it as a truly representative sample, it shall be discarded and a new sample or specimen substituted.

15.5 If the results of any chemical or mechanical property test lot are not in conformance with the requirements of this specification, the lot may be retested at the option of the manufacturer. Retests shall be made on double the original number of samples from the same lot. Both retest values shall conform to the requirements specified. These acceptable retest values will become the test values for certification.

15.6 If the results for the retest fail to conform to the specification, the material will be rejected.

15.7 *Rework*—If the results of the final sheet, strip, or plate inspections are not in conformance with the requirements of this specification, the lot may be reworked at the option of the manufacturer. The lot shall be acceptable if the results of all tests, after reworking, conform to this specification.

16. Sampling and Test Methods

16.1 *Sampling:*

16.1.1 Samples for chemical test shall be taken from the ingot or powder metallurgy bar. Care shall be taken to remove any surface contamination.

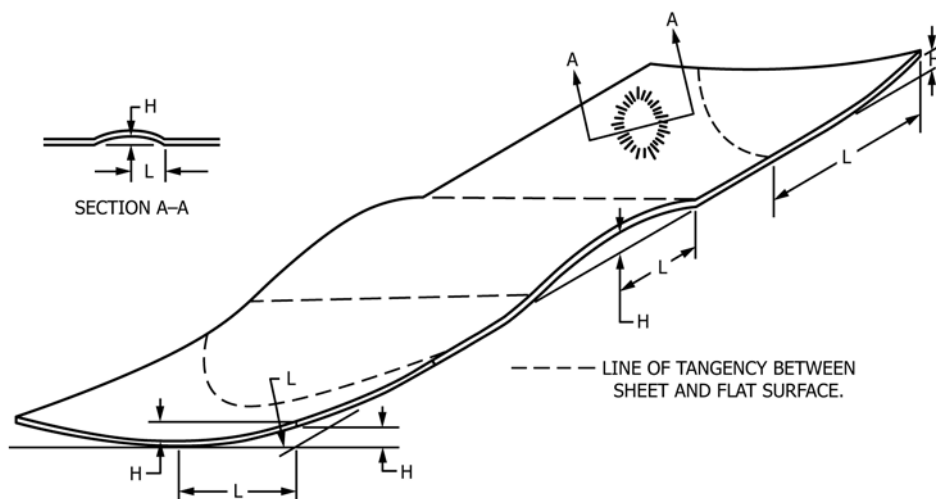

H = maximum distance between flat surface and lower surface of sheet.
 L = minimum distance between highest point on sheet and point of contact with flat surface.
 Flatness, percent = $(H/L) \times 100$

FIG. 1 Plate and Sheet Flatness Tolerances

16.1.2 Samples for mechanical testing shall be taken from the finished material after all metallurgical processing. The samples may be taken prior to final inspection and minor surface conditioning by abrasion and pickling shall be representative of the finished product.

16.1.3 Care shall be exercised to ensure that the sample selected for testing is representative of the material and that it is not contaminated by the sampling procedure. If there is any question relating to the sampling technique or the analysis thereof, the methods of sampling and analysis shall be as agreed upon between the purchaser and the manufacturer.

16.1.4 The utmost care must be used in sampling reactive metals for chemical analysis because of their great affinity for elements such as oxygen, carbon, nitrogen, and hydrogen. Therefore, in cutting samples for analysis, the operation should be carried out insofar as possible in a dust-free atmosphere. Chips should be collected from clean metal and tools should be clean and sharp. Samples for analysis should be stored in suitable containers.

16.2 Test Methods:

16.2.1 Chemistry:

16.2.1.1 Analyses shall be made using the manufacturer's standard methods.

16.2.1.2 The chemical composition enumerated in this specification shall in case of disagreement, be determined in accordance with the methods approved for referee purposes by ASTM. Where such methods are not available, methods of analysis as mutually agreed upon by the manufacturer and the purchaser shall be employed.

16.2.2 Tension Tests:

16.2.2.1 The room temperature tensile tests shall be conducted in accordance with Test Methods E8. The yield strength shall be determined by the offset (0.2 %) method. The tensile properties shall be determined using a strain rate of 0.003 to 0.007 in./in./min (mm/mm/min) through the yield strength. After the yield strength has been exceeded, the crosshead speed can be increased to approximately 0.05 in./in./ (mm/mm)/min.

16.2.2.2 Small size, 1-in. (25.4-mm) gage length specimens proportional to the standard specimen can be used.

16.3 *Recrystallization*—When fully recrystallized is specified, a sample of the “as shipped” plate, sheet, or strip shall be examined by common metallographic techniques (mount, polish, and etch) at 50X, 100X, or 200X or other magnification (as needed). Percent recrystallization shall be determined (by visual approximation) through the thickness of the plate. The total thickness of unrecrystallized areas (bands) divided by the thickness of the plate and multiplied by 100 shall not exceed 10 %. In other words, the plate, sheet, or strip shall be 90 % minimum recrystallized.

17. Rejection and Reheating

17.1 Material that fails to conform to the requirements of this specification may be rejected. Rejection for failure of the material to meet the requirements of this specification shall be reported to the manufacturer within 60 calendar days from the receipt of the material by the purchaser.

17.2 Unless otherwise specified, rejected material may be returned to the manufacturer at the manufacturer's expense, unless the purchaser receives, within four weeks of the notice of rejection, other instructions for disposition.

17.3 In the event of disagreement between the manufacturer and the purchaser on the conformance of the material to the requirements of this specification or any special test specified by the purchaser, a mutually acceptable referee shall perform the tests in question. The results of the referee's testing shall be used in determining conformance of the material to this specification.

18. Certification

18.1 The producer or supplier shall furnish the purchaser with a certificate that the material was manufactured, sampled, tested, and inspected in accordance with this specification and has been found to meet the requirements of the standard. The certificate shall report the test results of all tests required by the specification.

19. Product Marking

19.1 When specified, each plate, sheet, and strip shall be marked with the number of this specification, type, temper, lot number, manufacturer's identification, nominal thickness, in inches, and gross, net and tare weights. The characters shall be not less than $\frac{3}{8}$ in. (9.52 mm) in height, shall be applied using a suitable marking fluid, and shall be capable of being removed with a hot alkaline cleaning solution without rubbing. The marking shall have no deleterious effect on the material or its performance. The characters shall be sufficiently stable to withstand ordinary handling.

19.2 When specified, the plate or flat sheet, shall be marked in lengthwise rows of characters recurring at intervals not greater than 3 in. (75 mm), the rows being spaced not more than 2 in. (50 mm) apart and alternatively staggered.

19.3 When specified, coiled strip and sheet shall be marked near the outside of the coil.

20. Packaging and Package Marking

20.1 Unless otherwise specified, material purchased under this specification must be packed by box, or suitable protective containers.

20.2 All material shall be packaged in such a manner as to assure safe delivery to its destination when properly transported by any common carrier.

20.3 The package shall be marked as to indicate the nature of any special handling required.

20.4 Each bundle, box, or coil shall be legibly and conspicuously marked or tagged with the following information:

- 20.4.1 Purchase order or contract number,
- 20.4.2 Name of material,
- 20.4.3 Grade,
- 20.4.4 Size,
- 20.4.5 Lot, heat, or ingot number,
- 20.4.6 Condition,
- 20.4.7 Gross, net and tare weights, and

20.4.8 ASTM specification number.

21. Keywords

21.1 tantalum; tantalum niobium alloy; tantalum plate; tantalum sheet; tantalum strip; tantalum tungsten alloy; Ta-2.5 %W; Ta-10 %W; Ta-40 %Nb

SUPPLEMENTARY REQUIREMENTS

Supplementary requirements shall not apply unless specified in the order or contract.

S1. Special Flatness Requirement for Explosive Bonding

S1.1 When specifically requested, the flatness of tantalum or tantalum alloy plate or sheet to be used for explosive bonding applications shall be a maximum of 4 % or 6 mm per meter, whichever is less. The performance and inspection of this requirement shall be negotiated between the supplier and purchaser.

S2. Tantalum Plate for Sputtering Target Applications (R05200 or R05400 only)

S2.1 When specifically requested on the purchase order or contract, the following requirements for chemistry and metallurgical properties shall apply.

S2.2 Chemical Requirements:

S2.2.1 Tantalum Plate for sputtering target applications shall meet the chemical properties of [Table S2.1](#). 3N5 Purity (99.95 % min.) requirements shall be supplied unless the purchaser states another purity requirement on the purchase order or contract.

NOTE S2.2.1—Purity refers to 100 % minus total metallic elements only; gasses are omitted from the calculation.

S3. Metallurgical Properties

S3.1 Materials supplied under this specification for sputtering target applications shall conform to the requirements for metallurgical properties described in [Table S3.1](#).

S3.2 Tantalum for sputtering target applications does not need to be tested to the requirements of [Table 3](#) (nor must it meet the requirements for [Table 3](#)).

TABLE S2.1 Chemical Requirements (Tantalum for Sputtering Target Applications)

Element ^A	3N5	4N	4N5	5N
	Purity 99.95 % Min. (ppm max)	Purity 99.95 % Min. (ppm max)	Purity 99.95 % Min. (ppm max)	Purity 99.95 % Min. (ppm max)
C	40	40	40	40
O	100	100	100	100
N	40	40	40	40
H	10	10	10	10
S	1	1	1	1
Al	5	1	1	1
Ca	5	1	1	1
Cd	5	1	1	1
Cl	5	1	1	1
Co	5	1	1	1
Cr	5	1	1	1
Cu	5	1	1	1
Fe	5	1	1	1
Hf	5	1	1	1
K	1	1	1	1
Li	1	1	1	1
Mg	5	1	1	1
Mn	5	1	1	1
Mo	50	30	15	10
Na	1	1	1	1
Nb	400	80	40	10
Ni	5	1	1	1
Pb	5	1	1	1
Si	5	1	1	1
Sn	5	1	1	1
Ti	5	1	1	1
Th	0.005	0.005	0.005	0.005
V	5	1	1	1
W	150	80	30	10
Zn	5	1	1	1
Zr	5	1	1	1
Y	5	1	1	1
U	0.005	0.005	0.005	0.005
Others (each)	5	1	1	1
Total Metallic Elements	500	100	50	10

^A Metallic elements analyzed by GDMS, Gases (CONH) by Leco Methods.

TABLE S3.1 Metallurgical Properties for Tantalum Plate for Sputtering Target Applications

Nominal Gauge (inches)	Grain Size and Structure Requirements	
	Average Through Thickness Grain Size ^A	Recrystallization ^B
.125-.299	ASTM 4 (90 μ) or finer	95 % min.
.300-.500	ASTM 3 (125 μ) or finer	90 % min.
.501-.650	ASTM 2 (180 μ) or finer	90 % min.
.651-1.25	Not Specified	90 % min.

^A The structure of all material shall be uniform throughout the thickness of the plate. The grain size in individual areas shall not vary more than 2 ASTM grain size numbers from the average through thickness grain size. Grain Size shall be tested in accordance with Test Methods E112. Grain size expressed as microns is referring to the average grain diameter.

^B Percent recrystallization shall be measured (by visual approximation) through the thickness of the plate. The total thickness of unrecrystallized areas (bands) divided by the thickness of the plate and multiplied by 100 shall be less than the stated requirement.

ASTM International takes no position respecting the validity of any patent rights asserted in connection with any item mentioned in this standard. Users of this standard are expressly advised that determination of the validity of any such patent rights, and the risk of infringement of such rights, are entirely their own responsibility.

This standard is subject to revision at any time by the responsible technical committee and must be reviewed every five years and if not revised, either reapproved or withdrawn. Your comments are invited either for revision of this standard or for additional standards and should be addressed to ASTM International Headquarters. Your comments will receive careful consideration at a meeting of the responsible technical committee, which you may attend. If you feel that your comments have not received a fair hearing you should make your views known to the ASTM Committee on Standards, at the address shown below.

This standard is copyrighted by ASTM International, 100 Barr Harbor Drive, PO Box C700, West Conshohocken, PA 19428-2959, United States. Individual reprints (single or multiple copies) of this standard may be obtained by contacting ASTM at the above address or at 610-832-9585 (phone), 610-832-9555 (fax), or service@astm.org (e-mail); or through the ASTM website (www.astm.org). Permission rights to photocopy the standard may also be secured from the Copyright Clearance Center, 222 Rosewood Drive, Danvers, MA 01923, Tel: (978) 646-2600; http://www.copyright.com/