



Standard Test Method for Apparent Density of Metal Powders and Related Compounds Using the Arnold Meter¹

This standard is issued under the fixed designation B703; the number immediately following the designation indicates the year of original adoption or, in the case of revision, the year of last revision. A number in parentheses indicates the year of last reapproval. A superscript epsilon (ϵ) indicates an editorial change since the last revision or reapproval.

1. Scope*

1.1 This test method covers a quantitative laboratory procedure for determining the apparent density of both free-flowing and non-free-flowing metal powders, lubricated metal powder mixtures, and powder compounds.

1.2 With the exception of the values for mass, volume, and density, for which the use of the gram and the cubic centimetre units is the long-standing industry practice, the values stated in inch-pound units are to be regarded as standard. The values given in parentheses are mathematical conversions to SI units that are provided for information only and are not considered standard.

1.3 *This standard does not purport to address all of the safety concerns, if any, associated with its use. It is the responsibility of the user of this standard to establish appropriate safety and health practices and determine the applicability of regulatory limitations prior to use.*

2. Referenced Documents

2.1 ASTM Standards:²

- B212 Test Method for Apparent Density of Free-Flowing Metal Powders Using the Hall Flowmeter Funnel
- B215 Practices for Sampling Metal Powders
- B243 Terminology of Powder Metallurgy
- B329 Test Method for Apparent Density of Metal Powders and Compounds Using the Scott Volumeter
- B417 Test Method for Apparent Density of Non-Free-Flowing Metal Powders Using the Carney Funnel
- E177 Practice for Use of the Terms Precision and Bias in ASTM Test Methods
- E456 Terminology Relating to Quality and Statistics
- E691 Practice for Conducting an Interlaboratory Study to

¹ This test method is under the jurisdiction of ASTM Committee B09 on Metal Powders and Metal Powder Products and is the direct responsibility of Subcommittee B09.02 on Base Metal Powders.

Current edition approved Sept. 1, 2010. Published September 2010. Originally approved in 1983. Last previous edition approved in 2005 as B703 – 05. DOI: 10.1520/B0703-10.

² For referenced ASTM standards, visit the ASTM website, www.astm.org, or contact ASTM Customer Service at service@astm.org. For *Annual Book of ASTM Standards* volume information, refer to the standard's Document Summary page on the ASTM website.

Determine the Precision of a Test Method

2.2 MPIF Standard:³

MPIF 48 Determination of Apparent Density of Metal Powders Using the Arnold Meter

3. Terminology

3.1 *Definitions*—Useful definitions of terms for metal powders and powder metallurgy are found in Terminology B243. Additional descriptive PM information is available in the Related Materials section of Volume 02.05 of the *Annual Book of ASTM Standards*.

3.2 Definitions of Terms Specific to This Standard:

3.2.1 *Arnold Apparent Density (AD_A)*—the mass per unit volume of a powder, expressed in gram per cubic centimetre units, determined in accordance with the procedure in this test method.

3.2.2 *Arnold Meter*—the laboratory instrumentation pictured in Fig. 1, consisting of a steel die block with a precise cavity and a powder delivery cylinder, that is used to determine a quantitative value for Arnold Apparent Density, (AD_A).

4. Summary of Test Method

4.1 The test method consists of first collecting a 20 cm³ volume of the test powder by slowly sliding a cylindrical sleeve containing the test powder over a precise cavity in a die block.

4.2 The mass of the volume of powder thus collected is determined and the Arnold Apparent Density (AD_A), is calculated as mass divided by volume and expressed in g/cm³ units.

5. Significance and Use

5.1 The apparent density is an important measure of a material characteristic of the powder that is useful to the powder producers and powder users in determining quality and lot to lot consistency.

5.2 This test method is applicable to free-flowing and non-free-flowing metal powders, lubricated powder mixtures and metal compounds.

³ This report is available from Metal Powder Industries Federation, 105 College Road East, Princeton, NJ 08540

*A Summary of Changes section appears at the end of this standard

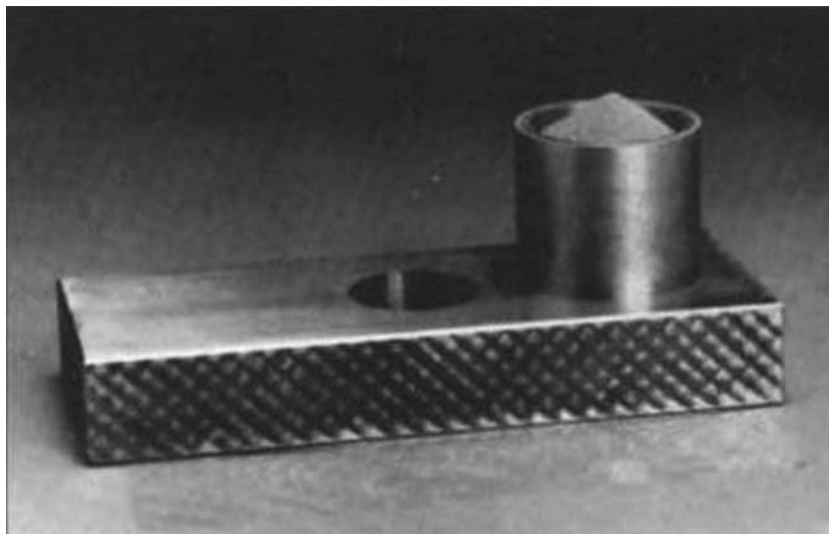

FIG. 1 Arnold Meter

5.3 The apparent density of a lubricated metal powder mixture may be different when a quantity settles after falling into the die cavity during automatic compacting as compared with the value obtained from a measurement taken in the laboratory under controlled test conditions.

5.4 This test method simulates the action of the feed shoe on a powder compacting press and gives an apparent density value that closely approximates the apparent density of the powder in the die cavity after the production filling operation.

5.5 Knowledge of this apparent density value for the final lubricated production powder mixture is very helpful to the powder metallurgy (PM) parts fabricator to set the compression ratios for fixed fill die cavity tooling.

5.6 The values of apparent density obtained on metal powders with this test method are approximately 0.2 g/cm^3 higher than those obtained using the Hall Funnel, Test Method B212, the Carney Funnel, Test Method B417; or the Scott Volumeter, Test Method B329.

5.7 This test method may be part of a purchase agreement between the powder supplier and PM parts producer, or it may be an internal quality control test for either party.

6. Apparatus

6.1 *Steel Die Block*⁴—A hardened, tempered (60 HRC min.), ground and demagnetized tool steel block approximately 6.50 by 2.50 in. (165 by 64 mm) and 1.0000 ± 0.0001 in. (25.400 ± 0.003 mm) in thickness, having a precise centrally located through-hole 1.2466 ± 0.0001 in. (31.664 ± 0.003 mm) in diameter with a volume of 20.0 cm^3 (see Fig. 2). The

surfaces of the sides of the die block shall be given a roughening treatment to aid in handling during use (see Fig. 1).

6.2 *Powder Delivery Cylinder*⁴—A nonferrous cylindrical sleeve, preferably brass or bronze, approximately 1.75 in. (44 mm) outside diameter and 1.50 in. (38 mm) inside diameter with a height of about 1.50 in. (38 mm), (see Fig. 2). The cylinder should be inscribed on the ID with a ring at approximately three quarters of its height to indicate 50 cm^3

6.3 *Weighing Paper*—A sheet of coated or waxed paper approximately 6.0 in. (150 mm) square.

6.4 *Balance*—A laboratory balance readable to 0.001 g, and with a capacity of at least 200 g, to be used for determining the mass of the test specimen to the nearest 0.01 g.

7. Test Sample

7.1 The test sample shall be approximately 50 cm^3 of powder, obtained in accordance with Practices B215, that will fill the delivery cylinder to about three quarters of its height.

8. Procedure

8.1 Tare the sheet of coated weighing paper and lay it on a flat level surface.

8.2 Thoroughly clean the steel die block and the powder delivery cylinder with a dry cotton cloth to remove any loose powder particles. Re-demagnetize the die if necessary.

8.3 Place the steel die block in the center of the sheet of tared paper.

8.4 Locate the empty delivery cylinder upright on the steel die block, on either side of the die cavity.

8.5 Carefully fill the delivery cylinder with the 50 cm^3 test sample of powder to the ring inscribed at three-quarters of its height.

8.6 With downward pressure on the delivery cylinder, slowly and smoothly slide it forward across the cavity while simultaneously rotating it. This produces a cascading action by

⁴ The sole source of supply of the Arnold Density Meter complete with bushing known to the committee at this time is Arnold P/M Consulting Services, 648 Cedar Road, St. Marys, PA 15857. An apparatus may be produced according to the drawings, Fig. 2, in this standard. If you are aware of alternative suppliers, please provide this information to ASTM International Headquarters. Your comments will receive careful consideration at a meeting of the responsible technical committee,¹ which you may attend.

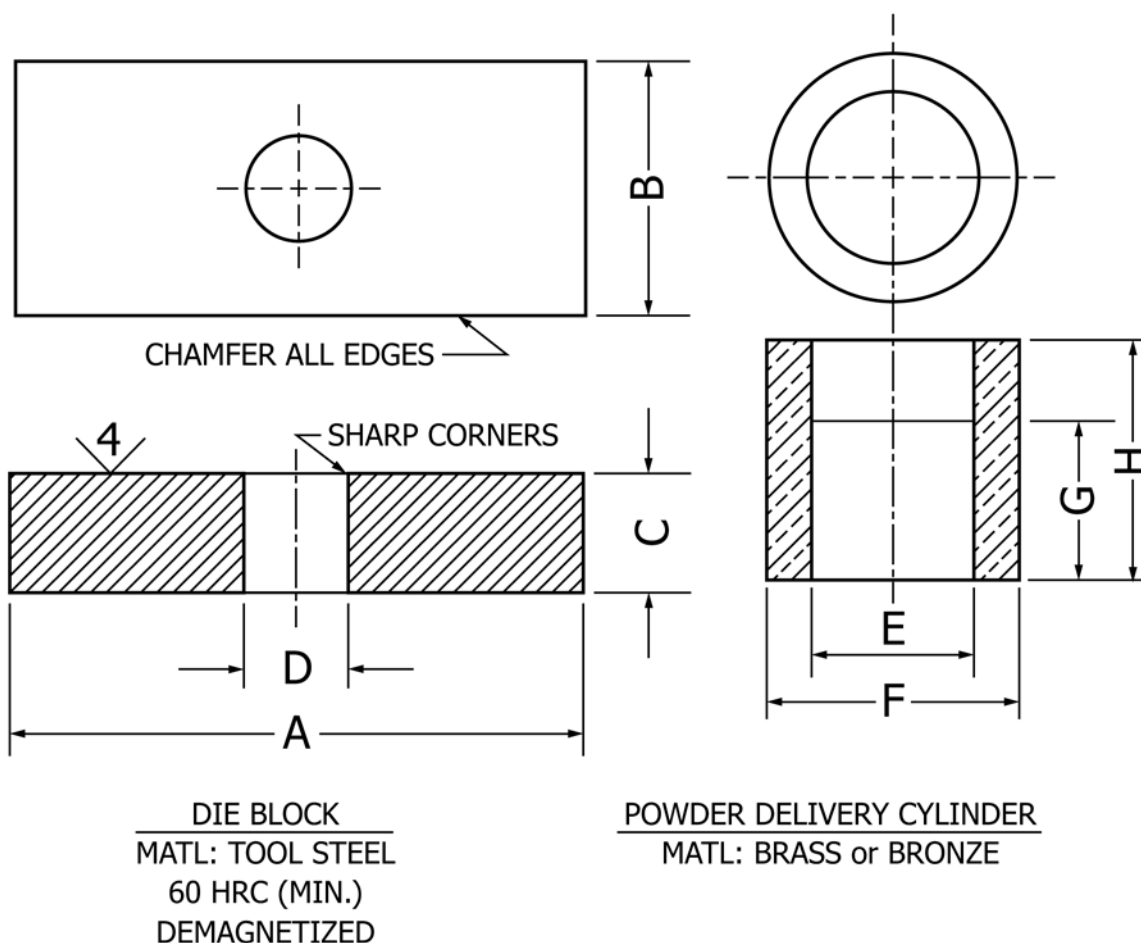

Letter	Dimensions	
	Inches	Millimetres
A	6.50	165
B	2.50	64
C	1.0000 ± 0.0001	25.400 ± 0.003
D	1.2466 ± 0.0001	31.664 ± 0.003
E	1.50	38
F	1.75	44
G	1.13	29
H	1.50	38

FIG. 2 Arnold Apparent Density Meter

the powder as it falls into the cavity. Continue these motions until the cylinder passes completely over the cavity. Then, maintaining downward pressure on the cylinder, slide it straight back over the cavity to the starting location. This sliding action must be slow enough to leave the cavity in the die block completely filled.

8.7 Slowly lift the die block together with the partially empty delivery cylinder off the weighing paper to allow the contents (the test specimen) of the die cavity to collect on the paper, being careful not to tip the block and possibly spill additional powder.

8.8 Transfer the pre-weighed paper with the powder to the balance and determine the mass of the powder collected to the nearest 0.01 g. This is M, the mass of the test specimen.

9. Calculation

9.1 Calculate the Arnold Apparent Density, (AD_A), from the following equation:

$$\text{Arnold Apparent Density, } (AD_A), \text{ g/cm}^3 = \frac{M}{V} \quad (1)$$

where:

M = mass of test specimen, g.

V = volume of die cavity, 20.0 cm³.

10. Report

10.1 Report the Arnold Apparent Density, (AD_A), as the arithmetic average of three determinations, taken on three separate test samples and rounded to the nearest 0.01 g/cm³.

11. Precision and Bias

11.1 *Interlaboratory Test Program*—An interlaboratory study of the Arnold Apparent Density test method was conducted by ASTM Subcommittee B09.02 in conjunction with the Metal Powder Producers Association of the Metal Powder Industries Federation in 1991. Each of eight laboratories tested three randomly drawn test samples from each of seven different metal powders. The design of the experiment followed the protocol of Practice E691, and an analysis of the within-between laboratory test data is contained in MPIF research report MPPA R-48-005³.

11.2 *Test Results*—The precision information presented herein has been calculated for the comparison of two test results, each of which is the average of three individual test determinations.

11.3 *95% Repeatability Limit (within a laboratory)*—The within a laboratory limit, r , as defined by Terminology E456, is estimated to be 0.08 g/cm³. At the 95% confidence level, duplicate Arnold Apparent Density test results from the same

laboratory should not be considered to be different unless they differ by more than 0.08 g/cm³.

11.4 *95% Reproducibility Limit (between laboratories)*—The between laboratories limit, R , as defined by Terminology E456, is estimated to be 0.17 g/cm³. At the 95% confidence level, two Arnold Apparent Density test results from two different laboratories should not be considered to be different unless they differ by more than 0.17 g/cm³.

11.5 *Bias*—No information can be presented on the bias of the procedure in this test method because no material that has an accepted reference value is available.

11.6 *Measurement Uncertainty*—The precision of this test method shall be considered by those performing the test when reporting Arnold Apparent Density test results.

12. Keywords

12.1 apparent density; Arnold Apparent Density; Arnold Meter; density of non-free-flowing powders; metal powders; production apparent density

SUMMARY OF CHANGES

Committee B09 has identified the location of selected changes to this standard since the last issue (B905 - 05) that may impact the use of this standard. (September 1, 2010)

- (1) Revised title to add “metal” and “related compounds.”
- (2) Revised 1.2 to reflect the change of this standard from an SI standard to an inch-pound standard in order to comply with ASTM rules regarding units.
- (3) Revised 2.1 to add reference to E177, E456, and E691.
- (4) Added 3.2.1 for the definition of Arnold Apparent Density.
- (5) Added new Fig. 1, photograph of the Arnold Meter.
- (6) Added new Fig. 2, drawn to ASTM standards.
- (7) Revised Section 5.
- (8) Rewrote and renumbered Section 8.
- (9) Renumbered and retitled section headings to agree with 2009 *Form and Style Manual for ASTM Standards*.
- (10) Rewrote Section 11 following the guidelines in E177.

ASTM International takes no position respecting the validity of any patent rights asserted in connection with any item mentioned in this standard. Users of this standard are expressly advised that determination of the validity of any such patent rights, and the risk of infringement of such rights, are entirely their own responsibility.

This standard is subject to revision at any time by the responsible technical committee and must be reviewed every five years and if not revised, either reapproved or withdrawn. Your comments are invited either for revision of this standard or for additional standards and should be addressed to ASTM International Headquarters. Your comments will receive careful consideration at a meeting of the responsible technical committee, which you may attend. If you feel that your comments have not received a fair hearing you should make your views known to the ASTM Committee on Standards, at the address shown below.

This standard is copyrighted by ASTM International, 100 Barr Harbor Drive, PO Box C700, West Conshohocken, PA 19428-2959, United States. Individual reprints (single or multiple copies) of this standard may be obtained by contacting ASTM at the above address or at 610-832-9585 (phone), 610-832-9555 (fax), or service@astm.org (e-mail); or through the ASTM website (www.astm.org). Permission rights to photocopy the standard may also be secured from the ASTM website (www.astm.org/COPYRIGHT/).