



Designation: B47 – 95a (Reapproved 2017)

Standard Specification for Copper Trolley Wire¹

This standard is issued under the fixed designation B47; the number immediately following the designation indicates the year of original adoption or, in the case of revision, the year of last revision. A number in parentheses indicates the year of last reapproval. A superscript epsilon (ϵ) indicates an editorial change since the last revision or reapproval.

1. Scope

1.1 This specification covers round and grooved hard-drawn copper and silver-bearing copper trolley wire.

1.2 The values stated in inch-pound units are to be regarded as standard. The values given in parentheses are mathematical conversions to SI units that are provided for information only and are not considered standard.

1.3 *This international standard was developed in accordance with internationally recognized principles on standardization established in the Decision on Principles for the Development of International Standards, Guides and Recommendations issued by the World Trade Organization Technical Barriers to Trade (TBT) Committee.*

2. Referenced Documents

2.1 *ASTM Standards:*²

[B49 Specification for Copper Rod for Electrical Purposes](#)
[B193 Test Method for Resistivity of Electrical Conductor Materials](#)

3. Ordering Information

3.1 Orders for material under this specification shall include the following information:

3.1.1 Quantity of each size and section,

3.1.2 Wire size: diameter in inches (see [6.1](#) and [Table 1](#)) or area in circular mils (see [10.1](#) and [Fig. 1](#)),

3.1.3 Shape of section (Section 1),

3.1.4 Type of copper, if the addition of silver of 25 troy oz./short ton minimum, is required (see Section 4 and Explanatory [Note 1](#)),

3.1.5 Package size (see [18.3](#)),

3.1.6 Lagging, if required (see [18.1](#)),

3.1.7 Relation between vertical axis of grooved wire and axis of reel (see [18.1](#)),

3.1.8 Size of arbor hole, if special (see [18.2](#)),

3.1.9 Special package marking, if required (see [18.4](#)), and

3.1.10 Place of inspection (Section [16](#)).

4. Materials and Manufacture

4.1 The material shall be copper of such quality and purity that the finished product shall have the properties and characteristics prescribed in this specification.

NOTE 1—Specification [B49](#) defines the materials suitable for use.

4.2 Copper redraw rod of special qualities, forms, or types, as may be agreed upon between the manufacturer and the purchaser, and that will conform to the requirements prescribed in this specification may also be used.

4.3 Either oxygen-free or tough pitch copper may be supplied. Tests for oxygen content of the copper are not a requirement of this specification.

ROUND WIRE

5. Tensile Properties

5.1 Round wire shall conform to the requirements as to tensile properties specified in [Table 1](#).

5.2 Tests on a specimen of round wire containing a joint shall show at least 95 % of the tensile strength specified in [Table 1](#). Elongation tests shall not be made on specimens containing joints.

5.3 Tension tests shall be made on representative samples. The elongation shall be determined as the permanent increase in length, due to the breaking of the wire in tension, measured between gage marks placed originally 10 in. apart upon the test specimen (Explanatory [Note 2](#)). The fracture shall be between the gage marks and not closer than 1 in. to either gage mark.

6. Dimensions and Permissible Variations

6.1 The size of round trolley wire shall be expressed as the diameter of the wire in decimal fractions of an inch, to the nearest 0.1 mil (0.0001 in.).

6.2 Wire shall be truly cylindrical in form. The diameter shall not vary more than plus and minus 1 % from that specified.

¹ This specification is under the jurisdiction of ASTM Committee B01 on Electrical Conductors and is the direct responsibility of B01.04 on Conductors of Copper and Copper Alloys.

Current edition approved April 1, 2017. April 2017. Originally approved in 1923 to replace portions of B1. Last previous edition approved in 2012 as B47 – 95a (2012). DOI: 10.1520/B0047-95AR17.

² For referenced ASTM standards, visit the ASTM website, www.astm.org, or contact ASTM Customer Service at service@astm.org. For *Annual Book of ASTM Standards* volume information, refer to the standard's Document Summary page on the ASTM website.

TABLE 1 Tensile Requirements (See Explanatory Note 2)

Diameter, in.	Area, cmils	Tensile Strength, min. psi		Elongation in 10 in., min. %
		No silver added	25 troy oz. min./short ton added	
0.5477	300 000	46 400	48 500	4.50
0.4600	211 600	49 000	51 500	3.75
0.4096	167 800	51 000	53 000	3.25
0.3648	133 100	52 800	54 000	2.80
0.3249	105 600	54 500	55 000	2.40

7. Twist Test

7.1 For the purpose of determining and developing defects which may be prejudicial to the life of trolley wire, owing to its peculiar service as compared to that of wire for other purposes, round wire shall be subjected to the twist test described in 7.2. Round wire that does not withstand at least 9 twists without breaking shall not be considered satisfactory.

7.2 Three twist tests shall be made on specimens 10 in. (254 mm) in length between the holders of the testing machine. The twisting machine shall be so constructed that there is a linear motion of the tail stock with respect to the head. The twist shall be applied not faster than 10 turns/min. All three specimens shall be twisted to destruction and shall not reveal under test any seams, pits, slivers, or surface imperfections of sufficient magnitude to indicate inherent defects or imperfections in the wire. At the time of fracture, the wire shall twist with reasonable uniformity.

GROOVED WIRE

8. Tensile Properties

8.1 Grooved wire shall conform to the requirements as to tensile properties specified in Table 2.

8.2 Tests on a specimen of grooved wire containing a joint shall show at least 95 % of the tensile strength specified in Table 2. Elongation tests shall not be made on specimens containing joints.

8.3 The tension and elongation tests for grooved wire shall be made in the same manner as those on round wire as described in 5.3.

9. Sections

9.1 Standard sections of grooved trolley wire shall be those known as the “American Standard Grooved Trolley Wire Sections” (the Standard Design of the American Transit Engineering Association) shown in Fig. 1.

10. Dimensions and Permissible Variations

10.1 The size of grooved trolley wire shall be expressed as the nominal area of cross section in circular mils, the standard sizes being as specified in Fig. 1.

10.2 The weight in pounds per mile of grooved trolley wire calculated from the weight of a specimen not less than 18 in. in length shall not vary more than plus and minus 4 % from that specified in Fig. 1.

10.3 Conformance of the trolley wire to the specified dimensions shall be determined by taking the measurements shown in Fig. 1 under the heading, “Dimensions for Inspection, in.” The shape of the groove shall be checked with the appropriate “go” and “no-go” slip gages described in Fig. 2. The gages shall be applied to the ends of the samples taken from each reel. Samples shall be clean and ends free from burrs. The groove shall be considered as conforming to these specifications if the “go” gage can be pushed on the straightened wire by hand and the “no-go” gage cannot be pushed on the wire.

11. Twist Test

11.1 The twist test shall be omitted.

ROUND AND GROOVED WIRE

12. Resistivity

12.1 Electrical resistivity shall be determined on representative samples by resistance measurements (Explanatory Note 4). At a temperature of 20°C the resistivity shall not exceed 900.77Ω·lb/mile².

12.2 Electrical resistivity shall be determined in accordance with Test Method B193.

13. Density

13.1 For the purpose of calculating weights, cross sections, etc., the density of the copper shall be taken as 8.89 g/cm³ (0.32117 lb/in.³) at 20°C (Explanatory Note 5).

14. Joints

14.1 No joints shall be made in the completed wire. Joints in the wire and rods made prior to final drawings shall be in accordance with the best commercial practice, and shall be capable of meeting the tensile strength requirements in 5.2 or 8.2.

15. Workmanship, Finish, and Appearance

15.1 The wire shall be of uniform size, shape, and quality throughout, and shall be free from all scale, flaws, splits and scratches not consistent with the best commercial practice.

16. Inspection

16.1 All tests governing the acceptance or rejection of the wire, unless otherwise specified, shall be made at the place of manufacture with apparatus furnished by the manufacturer and in the presence of the purchaser or his representative, who shall be furnished a copy of the tests. The manufacturer shall afford the inspector representing the purchaser all reasonable facilities, without charge, to satisfy him as to the reliability of the results before the wire is delivered. If the purchaser waives inspection, and if he so elects at that time, he shall be furnished with a certified copy of tests made by the manufacturer.

17. Rejection

17.1 Any reel of wire that fails to conform to the requirements prescribed in this specification may be rejected. Failure

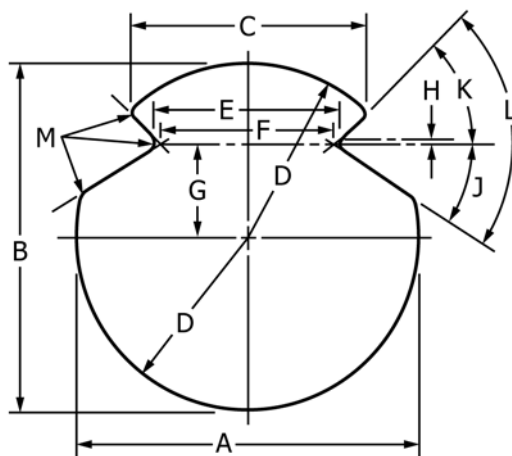

Nominal size, cmils	133 100	167 800	211 600	300 000	350 000
Area, in. ² (Explanatory Note 6)	0.1083	0.1314	0.1665	0.2355	0.2758
Area, cmils (Explanatory Note 6)	137 900	167 300	212 000	299 800	351 200
Weight, lb/mile (Explanatory Note 6)	2205	2674	3389	4792	5612
Dimensions for Inspection, in.					
A	0.388 + 0.006 - 0.012	0.429 + 0.006 - 0.012	0.482 + 0.006 - 0.012	0.574 + 0.010 - 0.020	0.620 + 0.010 - 0.020
B	0.392 ± 0.007	0.430 ± 0.008	0.482 ± 0.009	0.574 ± 0.011	0.620 ± 0.012
C	0.318 ± 0.007	0.340 ± 0.007	0.376 ± 0.007	0.376 ± 0.007	0.376 ± 0.007
Dimensions for Reference, in.					
D—radius	0.196	0.215	0.241	0.287	0.310
E	0.217 + 0.005 - 0.010	0.237 + 0.005 - 0.010	0.267 ± 0.010	0.267 ± 0.010	0.267 ± 0.010
F	0.200	0.220	0.250	0.250	0.250
G	0.031	0.047	0.063	0.127	0.156
H	0.005	0.005	0.005	0.005	0.005
J	27 ± 2°	27 ± 2°	27 ± 2°	27 ± 2°	27 ± 2°
K	51 ± 2°	51 ± 2°	51 ± 2°	51 ± 2°	51 ± 2°
L	78°	78°	78°	78°	78°
M—radius	0.015 + 0.010 - 0.005	0.015 + 0.010 - 0.005	0.015 + 0.010 - 0.005	0.015 + 0.010 - 0.005	0.015 + 0.010 - 0.005

NOTE 1—Dimension *H* is defined by two center lines, of which the upper is the center line of the radius of the groove and the lower is the center line of the groove.

FIG. 1 Standard Sections Grooved Trolley Wire

TABLE 2 Tensile Requirements (See Explanatory Note 2)

Nominal Area, cmils	Tensile Strength, min. psi		Elongation in 10 in., min, %
	No silver added	25 troy oz min./short ton added	
350 000	42 800	44 600	4.50
300 000	44 200	48 000	4.50
211 600	46 600	51 300	3.75
167 800	48 500	52 700	3.25
133 100	50 200	53 000	2.80

of 30 % of the number of reels ready for inspection at one time shall be deemed sufficient cause for the rejection of the whole lot.

18. Packaging and Package Marking

18.1 All wire shall be shipped on substantial reels, suitable for the weight of the wire handled, and shall be well protected from injury. The diameter of the reel drums shall be sufficiently large, not less than 30 in., (762 mm) to eliminate difficulty with waves or kinks when the wire is strung. If reels are to be

lagged, it shall be so specified by the purchaser. The wire shall be reeled with turns tightly together, in uniform layers, free from kinks and crosses. The relationship between the vertical axis of grooved wire as finally strung and the axis of the reel shall be as specified by the purchaser and shall be approximately constant.

18.2 The ends of the wire shall be securely fastened to the sides of the reel with no less than six staples. The staples shall be at least 2 in. (50 mm) in length and made from wire not less than 0.145 in. (3.7 mm) in diameter. Care shall be exercised in stapling so that there is no damage to the surface of the exposed layer of wire. All reels shall have the arbor holes reinforced with steel plate at least ½ in. in thickness. Unless otherwise specified, round arbor holes shall be for a 2½-in. (63.5-mm) shaft. Unless otherwise specified, shipments to railroads shall be made on reels having an arbor hole 4-in. (102-mm) square.

18.3 The length or weight of wire to be wound upon each reel shall be agreed upon between the manufacturer and the purchaser in placing individual orders.

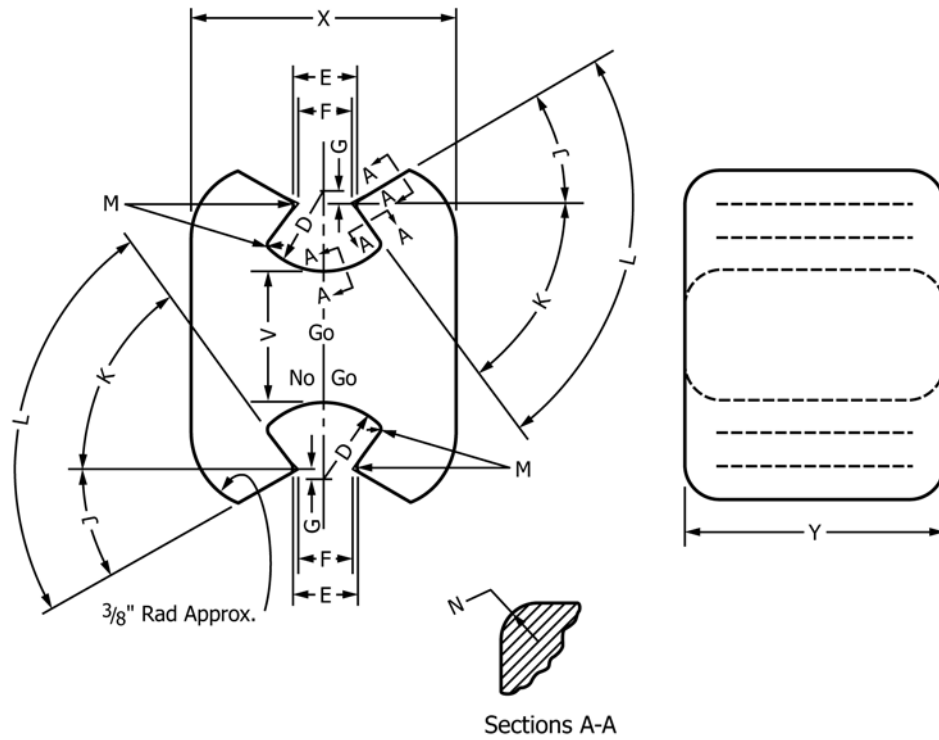

Dimension	Dimensions of Gage, in. (Except as Indicated)						
	For Trolley Wire of Nominal Size 133 100 cmil		For Trolley Wire of Nominal Size 167 800 cmil		For Trolley Wire of Nominal Sizes 211 600, 300 000, and 350 000 cmil		
	Go	No-Go	Go	No-Go	Go	No-Go	
D	5/16	5/16	5/16	5/16	5/16	5/16	
E	0.223 ± 0.0005	0.207 ^{+0.001} _{-0.000}	0.243 ± 0.0005	0.227 ^{+0.001} _{-0.001}	0.278 ± 0.0005	0.257 ^{+0.000} _{-0.000}	
F	0.212	0.200	0.235	0.220	0.268	0.248	
G	0.031	0.031	0.047	0.047	0.063	0.063	
J	25°	29°	25°	29°	25°	29°	
K	53°	53°	53°	53°	53°	53°	
L	78°	82°	78°	82°	78°	82°	
M—radius	0.010 ± 0.002	0.010 ± 0.002	0.010 ± 0.002	0.010 ± 0.002	0.010 ± 0.002	0.010 ± 0.002	
N—radius	5/16	5/16	5/16	5/16	5/16	5/16	
V	1/2	1/2	1/2	1/2	1/2	1/2	
X	1	1	1	1	1	1	
Y	1	1	1	1	1	1	

FIG. 2 Slip Gage for Testing Groove of Trolley Wire

18.4 Reels shall be marked legibly and indelibly with a serial number, size, kind, length, and weight of wire, and such other information as is specified by the purchaser.

EXPLANATORY NOTES

NOTE 1—Silver added to copper in the minimum amount of 25 troy oz./short ton substantially increases its resistance to softening (partial annealing) at elevated temperatures. For copper trolley wire, this means that it can be operated at a higher temperature for longer periods of time without losing its initial tensile strength. For specific conditions of current carrying capacity and corresponding expected temperature rise, refer to the manufacturer for engineering data.

NOTE 2—It is known that the rapidity with which load is applied to a sample during tension testing affects the performance of the sample to a greater or lesser extent, depending upon many factors. In general, tested values of tensile strength are increased and elongation values are reduced with increase of speed of the moving head of the testing machine. However, there are speeds below which no practical change is observable. It is suggested that tests be made at speeds of moving head which, under no-load conditions, are not greater than 3 in./min, (76 mm/min) but in no case at a speed greater than that at which correct readings can be made. No minimum restriction on speed of testing seems necessary.

NOTE 3—It is not the intention of this specification to imply that silver bearing copper has greater mechanical properties than non silver bearing. In fact, the addition of silver has no significant effect on the tensile strength of the alloy. The capability to achieve the higher tensile properties required for silver bearing copper is strictly a function of the manufacturer's process.

NOTE 4—"Resistivity" is used in place of "percentage conductivity." The value of 0.15328Ω·g/m² at 20°C is the international standard for the resistivity of annealed copper equal to 100 % conductivity. This term means that a wire 1 m in length and weighing 1 g would have a resistance of 0.15328 Ω. This is equivalent to a resistivity value of 875.20Ω·lb/mile²

which signifies the resistance of a wire 1 mile in length weighing 1 lb. It is also equivalent, for example, to 1.7241 μΩ/cm of length of a bar 1 cm² in cross section. A complete discussion of this subject is contained in *NBS Handbook 100* of the National Bureau of Standards.³ Relationships which may be useful in connection with the values of resistivity prescribed in this specification are as follows, each column containing equivalent expressions, at 20°C.

Conductivity at 20°C, %	100.00	97.16
Ω·lb/mile ²	875.20	900.77
Ω·g/m ²	0.15328	0.15775
Ω·cmil/ft	10.371	10.674
Ω·mm ² /m	0.017241	0.017745
μΩ·in.	0.67879	0.69863
μΩ·cm	1.7241	1.17745

NOTE 5—The value of the density of copper is in accordance with the International Annealed Copper Standard. The corresponding value at 0°C is 8.90 g/cm³ (0.32150 lb/in.³). As pointed out in the discussion of this subject in *NBS Handbook 100* there is no appreciable difference in values of density of hard-drawn and annealed copper wire.

NOTE 6—The values for area in square inches and circular mils as well as the weight in pounds per mile are calculated from the dimensions given in Fig. 1.

³ *NBS Handbook 100* available from National Technical Information Service (NTIS), 5301 Shawnee Rd., Alexandria, VA 22312, <http://www.ntis.gov>.

ASTM International takes no position respecting the validity of any patent rights asserted in connection with any item mentioned in this standard. Users of this standard are expressly advised that determination of the validity of any such patent rights, and the risk of infringement of such rights, are entirely their own responsibility.

This standard is subject to revision at any time by the responsible technical committee and must be reviewed every five years and if not revised, either reapproved or withdrawn. Your comments are invited either for revision of this standard or for additional standards and should be addressed to ASTM International Headquarters. Your comments will receive careful consideration at a meeting of the responsible technical committee, which you may attend. If you feel that your comments have not received a fair hearing you should make your views known to the ASTM Committee on Standards, at the address shown below.

This standard is copyrighted by ASTM International, 100 Barr Harbor Drive, PO Box C700, West Conshohocken, PA 19428-2959, United States. Individual reprints (single or multiple copies) of this standard may be obtained by contacting ASTM at the above address or at 610-832-9585 (phone), 610-832-9555 (fax), or service@astm.org (e-mail); or through the ASTM website (www.astm.org). Permission rights to photocopy the standard may also be secured from the Copyright Clearance Center, 222 Rosewood Drive, Danvers, MA 01923, Tel: (978) 646-2600; <http://www.copyright.com/>