



Standard Test Method for Modulus of Elasticity of Thermostat Metals (Cantilever Beam Method)¹

This standard is issued under the fixed designation B223; the number immediately following the designation indicates the year of original adoption or, in the case of revision, the year of last revision. A number in parentheses indicates the year of last reapproval. A superscript epsilon (ϵ) indicates an editorial change since the last revision or reapproval.

1. Scope

1.1 This test method covers the determination of the modulus of elasticity of thermostat metals at any temperature between -300 and $+1000^{\circ}\text{F}$ (-185 and 540°C) by mounting the specimen as a cantilever beam and measuring the deflection when subjected to a mechanical load.

1.2 The values stated in inch-pound units are to be regarded as standard. The values given in parentheses are mathematical conversions to SI units that are provided for information only and are not considered standard.

1.3 *This standard does not purport to address all of the safety concerns, if any, associated with its use. It is the responsibility of the user of this standard to become familiar with all hazards including those identified in the appropriate Material Safety Data Sheet (MSDS) for this product/material as provided by the manufacturer; to establish appropriate safety and health practices, and determine the applicability of regulatory limitations prior to use.*

2. Referenced Documents

2.1 *ASTM Standards:*²

B388 Specification for Thermostat Metal Sheet and Strip

3. Terminology

3.1 *Definitions:*

3.1.1 *thermostat metal, n*—a composite material, usually in the form of sheet or strip, comprising two or more materials of any appropriate nature, metallic or otherwise, which, by virtue of the differing expansivities of the components, tends to alter its curvature when its temperature is changed.

3.1.2 *modulus of elasticity, n*—the ratio, within the elastic limit of a material, of stress to corresponding strain. In this test

¹ This test method is under the jurisdiction of ASTM Committee B02 on Nonferrous Metals and Alloys and is the direct responsibility of Subcommittee B02.10 on Thermostat Metals and Electrical Resistance Heating Materials.

Current edition approved Aug. 1, 2013. Published August 2013. Originally approved in 1948. Last previous edition approved in 2008 as B223 – 08. DOI: 10.1520/B0223-08R13.

² For referenced ASTM standards, visit the ASTM website, www.astm.org, or contact ASTM Customer Service at service@astm.org. For *Annual Book of ASTM Standards* volume information, refer to the standard's Document Summary page on the ASTM website.

method the modulus of elasticity is calculated from the expression for the deflection of a cantilever beam under mechanical load which is transposed to read as follows:

$$E = 4P^2/dbt^3$$

where:

E = modulus of elasticity, psi or MPa,

P = load, lbf or N,

l = gage length, in. or mm,

d = specimen deflection, in. or mm,

b = specimen width, in. or mm, and

t = specimen thickness, in. or mm.

4. Apparatus (Figs. 1-3)

4.1 *Specimen Holder* for securely clamping the test specimen in a horizontal position as a cantilever beam when immersed in a bath at the desired temperature. It shall carry a micrometer depth gage for reading the deflection of the specimen and a loading rod for loading the specimen. Both of these shall extend sufficiently above the liquid level of the bath to permit the operator to perform the test at the higher test temperatures.

4.1.1 Specimen holder to be made sufficiently rigid to allow normal handling without distortion.

4.2 *Loading Rod*, $\frac{1}{8}$ in. (3.2 mm) or less in diameter, for carrying the load and transmitting its weight vertically to the free end of the cantilever specimen. It shall be made of a low expansion material; the mounting clamp and tube shall be made of the same material as the specimen mounting clamps in order to prevent a difference in expansion rates from affecting the deflection readings. The bottom end shall be conically shaped and shall rest in the conical punch mark at the free end of the specimen. Any supports shall permit free movement with specimen deflection and shall provide electrical insulation from the micrometer depth gage. Near the top shall be a holder for supporting the load. The weight of the loading rod and holder shall be no greater than 1 oz (28 g).

4.3 *Micrometer Depth Gage*, for measuring the deflection of the specimen to the nearest 0.0001 in. (0.002 mm). It shall be mounted directly over the loading rod. The micrometer shaft shall be in the same vertical line as the loading rod, so that readings can be taken of the top of the loading rod for no-load

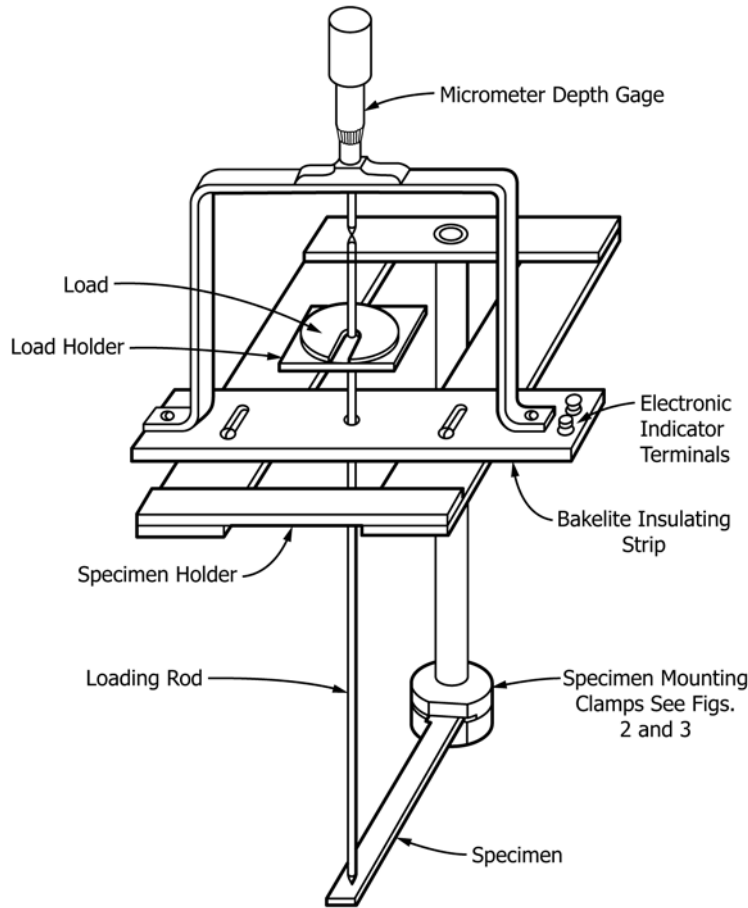

FIG. 1 Testing Machine for Determining Modulus of Elasticity of Thermostat Metal

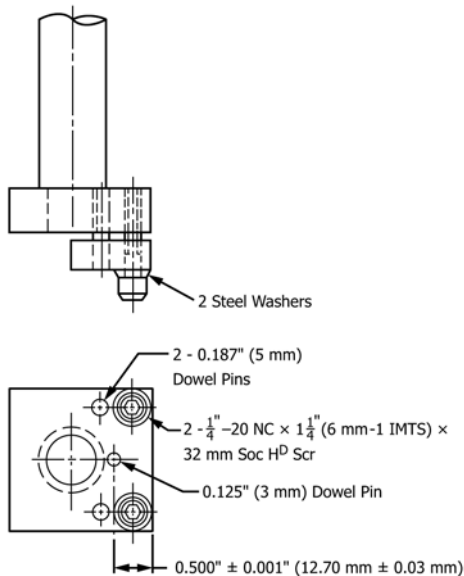

FIG. 2 Specimen Mounting Clamp Assembly

and full-load positions. The gage shall be insulated electrically from the specimen holder and the loading rod.

4.4 *Load*, constructed so that when placed in the holder, its center of gravity will coincide with the center of the loading rod. It shall be readily detachable for the operator's conve-

nience in taking no-load and full-load readings and shall not be of sufficient weight to deflect the specimen more than 0.30 in. (7.6 mm).

4.5 *Bath*—A stirred liquid so that the temperature shall be substantially constant during the test.

4.6 *Electronic Indicator*, sensitive, low-current, to give a signal when the micrometer depth gage shaft completes the electrical circuit across the indicator terminals by touching the top of the loading rod. The indicator sensitivity shall be such that loading rod positions can be determined with a precision of ± 0.0001 in. (0.002 mm).

4.7 All metallic components of apparatus, excluding micrometer and loads, should be made of very low coefficient of thermal expansion materials. The recommended material is invar.

5. Precautions

5.1 Load and no-load readings of the various trials will not approximately duplicate each other in the event the load is sufficiently great to overstress the specimen beyond its elastic limit. In this case a new specimen shall be substituted and a lighter load used which will not overstress the material.

5.2 Modulus of elasticity measurements to be within the maximum recommended temperatures as stated in Specification B388.

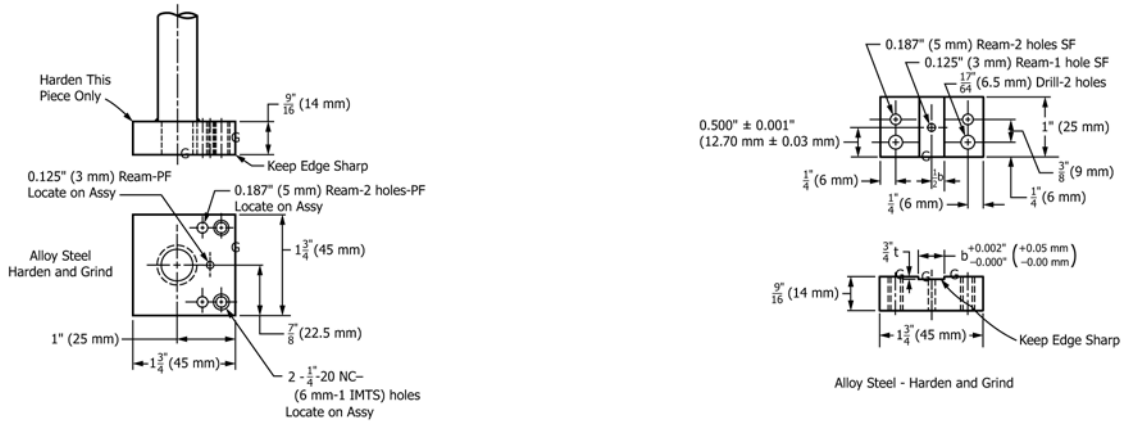

FIG. 3 Specimen Mounting Clamp Details

6. Test Specimen

6.1 The test specimen shall be the form of a strip approximately $1\frac{1}{4}$ in. (31.8 mm) longer than the gage length. The thickness may be any value between 0.015 and 0.055 in. (0.38 and 1.40 mm); however, corresponding width values shall conform with those in Fig. 4. Width and thickness dimensions shall be determined with a precision of ± 0.0001 in. (0.002 mm).

7. Preparation of Specimen

7.1 *Gage Length*—The gage length shall be the distance on the specimen between the center of the punch mark that supports the loading rod and the edge of the specimen holder clamps. This punch mark shall be approximately one half of the thickness of the specimen deep and located on the center line $\frac{1}{4}$ in. (6.4 mm) from the free end on low expansion side surface. To obtain the necessary accuracy in gage length, the

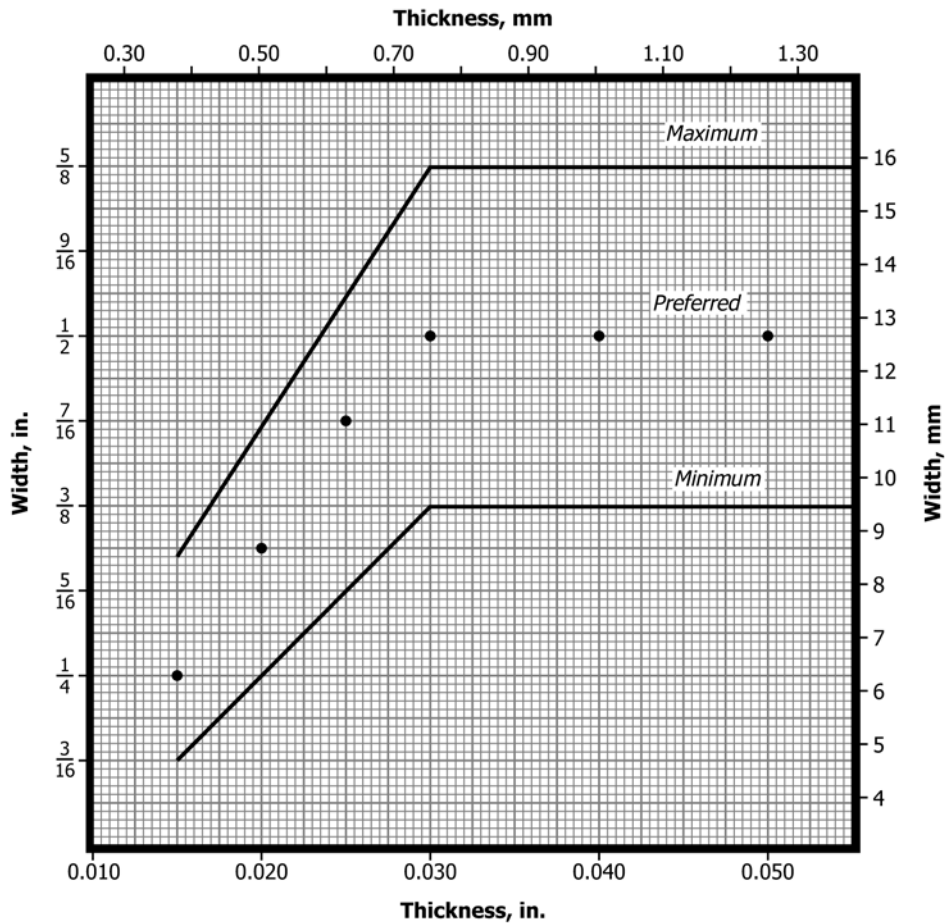

FIG. 4 Width of Test Specimen

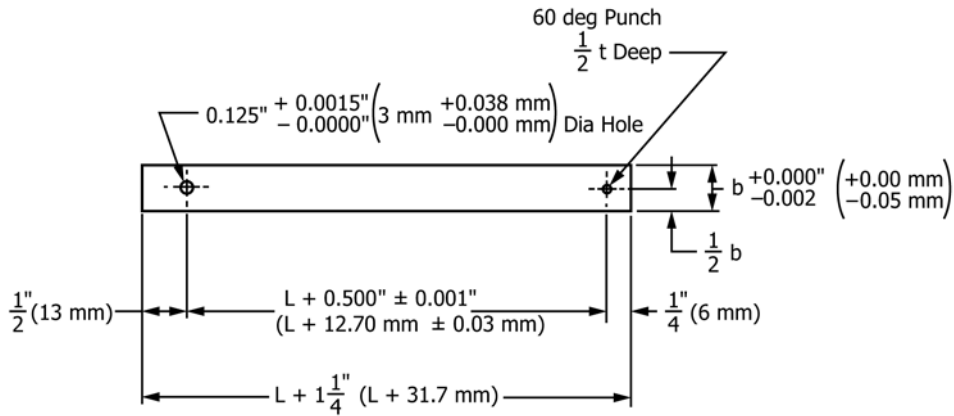

FIG. 5 Specimen

specimen shall be made as shown in Fig. 5 which, when the specimen is placed in the specimen mounting clamps, will maintain the gage length with a tolerance of ± 0.003 in. (0.08 mm). Table 1 gives the gage lengths for various specimen thicknesses.

NOTE 1—For thicknesses, widths, and lengths not covered by this test method, the procedure shall be agreed between the manufacturer and the purchaser.

7.2 After being roughly cut, slit, or sheared from the sample, the test specimen shall be finished to size by careful machining or filing.

7.3 *Preforming Operation*—The specimen shall be preformed into a shape approximating the segment of a circle. The amount of this preforming shall be such that, when subjected to the desired temperature, the specimen will take an upward curvature sufficient to cause the no-load and full-load deflection positions to be approximately equally distant above and below the straight position (Fig. 6).

7.4 *Heat Treatment*—After the preforming work has been completed the specimen shall be heat treated to relieve all internal stresses. This treatment shall consist of heating the specimen while free to bend at a prescribed temperature and for a prescribed time. Heat treatment shall be at least 50°F higher than the maximum tested temperature at a soak time of 1 h. The details of this procedure will depend on the characteristics of the thermostat metal and shall be mutually agreed upon by the manufacturer and the purchaser.

7.5 *Marking*—Any identification marking shall be placed on that part of the fixed end of the specimen not included in the gage length.

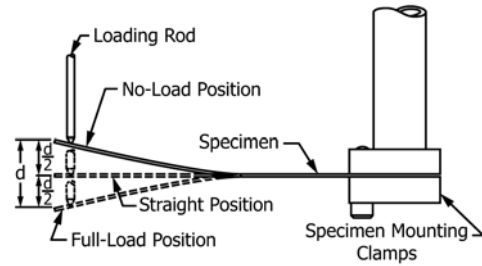

FIG. 6 Relationship of Specimen No-Load, Straight, and Full-Load Positions at Test Temperature

8. Procedure

8.1 *Cleaning*—Carefully remove any oxide coating and other foreign substances from all those surfaces which directly affect the electrical resistance of the electronic indicator circuit through the testing apparatus. This operation is necessary to permit maximum sensitivity of the indicator. The top of the loading rod which touches the micrometer depth gage shaft may be ground to a point in order to further increase the indicator sensitivity.

8.2 *Test Routine*—Clamp the specimen securely in the specimen holder using the 0.125-in. (3.18-mm) dowel hole and 0.125-in. dowel pin for accurate positioning. Lower the bottom part of the specimen holder with the specimen into the bath of the desired temperature and support the apparatus rigidly. Place the lower end of the loading rod in the punch mark at the free end of the specimen. Connect the electronic indicator to terminals on the specimen holder. When satisfactory initial conditions have been established, adjust the micrometer depth gage until the electronic indicator signals that the gage shaft is touching the loading rod and record this position as the no-load reading. Deflect the specimen by placing the load on the load holder and record this position of the rod as the load reading. The difference between these two readings will be the amount of deflection. Obtain an average value of deflection from ten or more trials.

8.3 *Calculation of Modulus of Elasticity*—Substituting the specimen size and the average deflection for a known load in the equation in 3.1.2, calculate the modulus of elasticity, E , as in the following example:

TABLE 1 Gage Length of Test Specimen

Specimen Thickness		Gage Length	
in.	mm	in.	mm
0.015 to 0.0199, incl	0.38 to 0.509, incl	$2\frac{1}{2} \pm \frac{1}{2}$	63.5 ± 1.3
0.020 to 0.0249, incl	0.51 to 0.639, incl	$3 \pm \frac{1}{2}$	76.2 ± 1.3
0.025 to 0.0299, incl	0.64 to 0.759, incl	$3\frac{1}{2} \pm \frac{1}{2}$	88.9 ± 1.3
0.030 to 0.0349, incl	0.76 to 0.889, incl	$4 \pm \frac{1}{2}$	101.6 ± 1.3
0.035 to 0.0449, incl	0.89 to 1.139, incl	$4\frac{1}{2} \pm \frac{1}{2}$	114.3 ± 1.3
0.045 to 0.055, incl	1.14 to 1.40, incl	$5 \pm \frac{1}{2}$	127.0 ± 1.3



$$E = 4PF^3/dbt^3$$

where:

$P = 4.00 \text{ ozf} = 0.250 \text{ lbf}$ or 1.112 N ,

$l = 4.00 \text{ in.}$ or 101.6 mm ,

$d = 0.1863 \text{ in.}$ or 4.732 mm ,

$b = 0.5000 \text{ in.}$ or 12.700 mm , and

$t = 0.0301 \text{ in.}$ or 0.765 mm .

Substituting the known values,

$$E = (4 \times 0.250 \text{ lbf} \times (4.00 \text{ in.})^3) / (0.1863 \text{ in.} \times 0.500 \text{ in.} \times (0.0301 \text{ in.})^3)$$

$$E = 25\,194\,029 \text{ psi.}$$

or

$$E = (4 \times 1.112 \text{ N} \times (101.6 \text{ mm})^3) / (4.732 \text{ mm} \times 12.700 \text{ mm} \times (0.765 \text{ mm})^3)$$

$$E = 173\,386 \text{ MPa.}$$

9. Report

9.1 The report shall include the following:

9.1.1 Type of thermostat metal,

9.1.2 Dimensions of specimen in inches or millimetres,

9.1.3 Temperature of test,

9.1.4 Direction of grain on specimen, and

9.1.5 Modulus of elasticity in pounds-force per square inch or megapascals.

10. Precision and Bias

10.1 *Precision*—The precision of this test method was performed in accordance with the test procedure and load known to $\pm 0.04\%$ results in a 2-sigma measurement precision of $\pm 1.8\%$.

10.2 *Bias*—Comparison to accepted reference values indicates lack of bias.

11. Keywords

11.1 cantilever; loading rod; modulus of elasticity; thermostat metal

ASTM International takes no position respecting the validity of any patent rights asserted in connection with any item mentioned in this standard. Users of this standard are expressly advised that determination of the validity of any such patent rights, and the risk of infringement of such rights, are entirely their own responsibility.

This standard is subject to revision at any time by the responsible technical committee and must be reviewed every five years and if not revised, either reapproved or withdrawn. Your comments are invited either for revision of this standard or for additional standards and should be addressed to ASTM International Headquarters. Your comments will receive careful consideration at a meeting of the responsible technical committee, which you may attend. If you feel that your comments have not received a fair hearing you should make your views known to the ASTM Committee on Standards, at the address shown below.

This standard is copyrighted by ASTM International, 100 Barr Harbor Drive, PO Box C700, West Conshohocken, PA 19428-2959, United States. Individual reprints (single or multiple copies) of this standard may be obtained by contacting ASTM at the above address or at 610-832-9585 (phone), 610-832-9555 (fax), or service@astm.org (e-mail); or through the ASTM website (www.astm.org). Permission rights to photocopy the standard may also be secured from the Copyright Clearance Center, 222 Rosewood Drive, Danvers, MA 01923, Tel: (978) 646-2600; http://www.copyright.com/